



PS 7464

HIGHLAND

Safety Guide & Assembly Instructions



PS 7958



PS 8870



PS 8826



We're Here To Help!

Call Toll Free 1-888-752-9782
Customer Service: Monday - Friday, 8:00 A.M. to 5:00 P.M. C.S.T.

SAFETY

- This product is intended for single-family residential use only, by children ages two to ten and a maximum weight of 105 pounds. Any recommendation over 10 years of age or 105 pounds exceeds the upper limits specified in the American Society for Testing and Materials (ASTM) Home Playground Safety Standard. In order for PlayStar to comply with the ASTM Standard, we cannot recommend anyone above these limits.
- It is a misuse of this product when installed or used in places of public assembly such as schools or parks.
- Follow the instructions provided, do not alter its design in any way.
- Construction requires at least two adults capable of heavy lifting.
- Thoroughly read all safety instructions before beginning.
- Children must remain clear of construction site until this product is properly installed and ready for use.
- Save these instructions in the event the manufacturer has to be contacted.

The Consumer Product Safety Commission provides the following consumer information for your Home Playground Equipment

Select Protective Surfacing

One of the most important things you can do to reduce the likelihood of serious head injuries is to install shock-absorbing protective surfacing under and around your play equipment. The protective surfacing should be applied to a depth that is suitable for the equipment height in accordance with ASTM F1292. There are different types of surfacing to choose from; whichever product you select, follow these guidelines:

NOTE: Do not install home playground equipment over concrete, asphalt, packed earth, grass, carpet or any other hard surface. A fall onto a hard surface can result in serious injury or death to the equipment user. Grass and dirt are not considered protective surfacing because wear and environmental factors can reduce their shock absorbing effectiveness. Carpeting and thin mats are generally not adequate protective surfacing. Ground level equipment -- such as a sandbox, activity wall, playhouse or other equipment that has no elevated play surface -- does not need any protective surfacing.

Loose-Fill Materials

PlayStar Playsets require fall-height protection from eight feet.

- Maintain a minimum depth of 9 inches of loose-fill materials such as wood mulch / chips, engineered wood fiber (EWF), or shredded/recycled rubber mulch for

equipment up to 8 feet high. NOTE: An initial fill level of 12 inches will compress to about a 9-inch depth of surfacing over time. The surfacing will also compact, displace, and settle, and should be periodically refilled to maintain at least a 9-inch depth.

- Use containment, such as digging out around the perimeter and/or lining the perimeter with landscape edging. Don't forget to account for water drainage.
- Check and maintain the depth of the loose-fill surfacing material. To maintain the right amount of loose-fill materials, mark the correct level on play equipment support posts. That way you can easily see when to replenish and/or redistribute the surfacing.
- **Do not** install loose fill surfacing over hard surfaces such as concrete or asphalt.

Poured-In-Place Surfaces or Pre-Manufactured Rubber Tiles

You may be interested in using surfacing other than loose-fill materials -- like rubber tiles or poured-in-place surfaces.

- Installations of these surfaces generally require a professional and are not "do-it-yourself" projects.
- Review surface specifications before purchasing this type of surfacing. Ask the installer/manufacturer for a report showing that the product has been tested to the following safety standard: ASTM F1292 *Standard Specification for Impact Attenuation of Surfacing Materials within the Use Zone of Playground Equipment*. This report should show the specific height for which the surface is intended to protect against serious head injury.

This height should be equal to or greater than the *fall height* - vertical distance between a designated play surface (*elevated surface for standing, sitting, or climbing*) and the protective surfacing below - of your play equipment.

- Check the protective surfacing frequently for wear.

Placement

Proper placement and maintenance of protective surfacing is essential. Be sure to;

- Extend surfacing at least 6 feet from the equipment in all directions.
- For to-fro swings, extend protective surfacing in front of and behind the swing to a distance equal to twice the height of the top bar from which the swing is suspended.

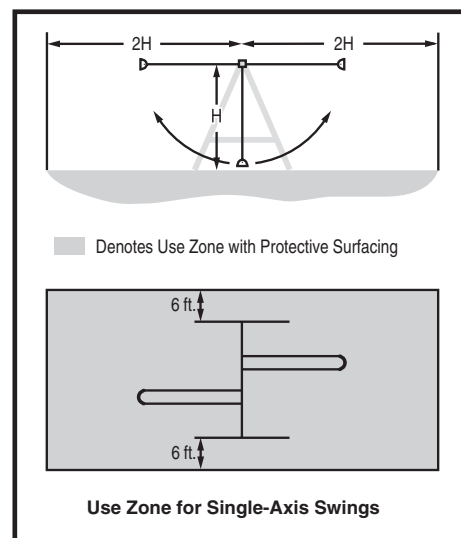

SAFETY

INSTALLATION:

1. Follow the instructions provided, do not alter its design in any way.
2. Place the equipment on level ground, not less than 6' (1.8m) from any structure or obstruction such as a fence, garage, house, overhanging branches, laundry lines or electrical wires. If the area where you will be installing your playset is not level, you must make it level.
3. Playsets must be anchored to the ground. Follow the anchoring instructions provided with your building kit. If soil conditions permit anchors to be pulled out easily, such as in sandy soil conditions, cementing is required.
4. Tighten all bolts securely to the intended member then cut off all protruding threaded ends of bolts with a hack saw **flush to the end of the nut** and remove sharp edges with a metal file.

WARNING: Children must not use the playset until properly installed and proper shock-absorbing surfacing material is in place.

OPERATION: *Observing and following statements and warnings reduces the likelihood of serious or fatal injury.*

1. On-site adult supervision is recommended for children of all ages.

2. Only one child, for each single planned seat or single planned activity should be allowed on this set at one time, with a maximum weight of **105 pounds** for each child.

WARNING: You must teach children the following:

- A. **Not** to walk close to, in front of, behind, or between moving items.
 - B. **Not** to twist swing chains or ropes or loop them over the top support bar since this may reduce the strength of the chain or rope.
 - C. **Avoid** swinging empty seats.
 - D. **To Sit** in the center of the swings with their full weight on the seats.
 - E. **Not** to use the equipment in a manner other than intended.
 - F. **Not** to get off equipment while it is in motion.
 - G. **Not** to climb when equipment is wet.
 - H. **Not** to attach items to the playground equipment that are not specifically designed for use with the equipment such as, but not limited to, jump ropes, clothesline, pet leashes, cables and chain as they may cause a strangulation hazard.
1. **Remove** bike or other sports helmet before playing on the playground equipment.
 3. Verify that suspended climbing ropes are secured at both ends and that they cannot be looped back on themselves.

4. Dress children appropriately and do not allow them to wear inappropriate items, such as but not limited to, loose fitting clothing, hood and neck draw strings, scarves, cord-connected items, capes, and ponchos. These items can cause death by strangulation. Provide well-fitting and full enclosure footwear. Examples of inappropriate footwear are clogs, flip flops, and sandals.
5. Verify that all suspended swinging components have at least 8" clearance between the lowest point of component and top of shock-absorbing surfacing material.

WARNING: Lawn swings are designed for use by children two years of age and older. Use by children under the age of two can result in entrapment between the seat and backrest. **NEVER** place children in a rearward facing position or with legs between the seat and backrest because the child's body may pass through the opening causing entrapment of the child's head.

DISPOSAL:

When the playset is to be retired from service, disassemble and dispose of in such a way that no unreasonable hazards will exist. Follow your local disposal requirements.



ANNUAL MAINTENANCE CHECKLIST

(Copy this section as needed and maintain for your records or visit www.playstarinc.com/maintenance)

At the beginning of play season: Date: _____

- Tighten all hardware.
- Lubricate all metallic moving parts per manufacturer's instructions.
- Check all protective coverings on bolts, pipes, edges, and corners. Replace if they are loose, cracked, or missing.
- Check all moving parts including swing seats, ropes, cables, and chains for wear, rust, or other deterioration. Replace as needed.
- Check metal parts for rust. If found, sand and repaint using a non lead-based paint meeting the requirements of 16 CRF 1303.
- Check all wood members for deterioration and splinters. Sand down splinters and replace deteriorating wood members.
- Reinstall any plastic parts, such as swing seats or any other items that were removed for the cold season.
- Rake and check depth of loose fill protective surfacing materials to prevent compaction and to maintain appropriate depth. Replace as necessary.

Twice a month during play season: Date: _____

- Tighten all hardware.
- Check all protective coverings on bolts, pipes, edges, and corners. Replace if they are loose, cracked, or missing.
- Rake and check depth of loose fill protective surfacing materials to prevent compaction and to maintain appropriate depth. Replace as necessary.

Once a month during play season: Date: _____

- Lubricate all metallic moving parts per manufacturer's instructions.
- Check all moving parts including swing seats, ropes, cables, and chains for wear, rust, or other deterioration. Replace as needed.

At the end of each play season or when the temperature drops below 0° F: Date: _____

- Remove plastic swing seats and other items as specified by the manufacturer and take indoors or do not use.
- Rake and check depth of loose fill protective surfacing materials to prevent compaction and to maintain appropriate depth. Replace as necessary.

Owner shall be responsible for maintaining the legibility of any warning labels.

If any of these conditions exist, call 1-888-752-9782 for ordering information.

Clean plastic components with warm water and a mild detergent such as dish soap.

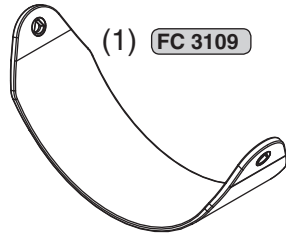
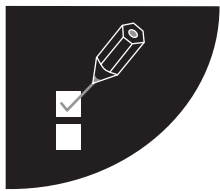

(1) FC 3109

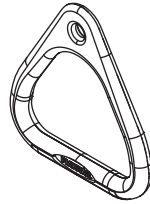

(8) FC 3110

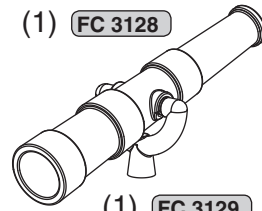

(1) FC 3128

(1) FC 3129

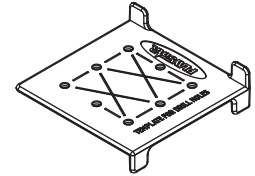

(1) FC 3175

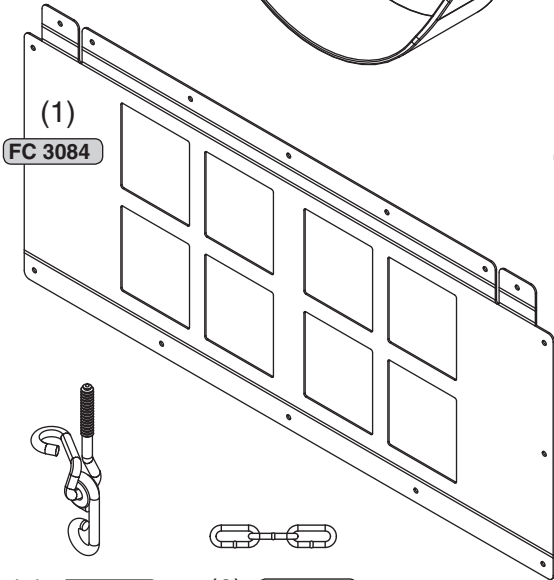

(1) FC 3084

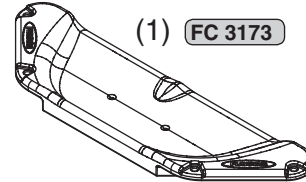

(1) FC 3173

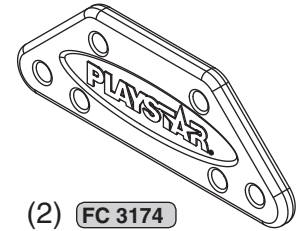

(2) FC 3174



(6) FC 3111



(6) FC 3108

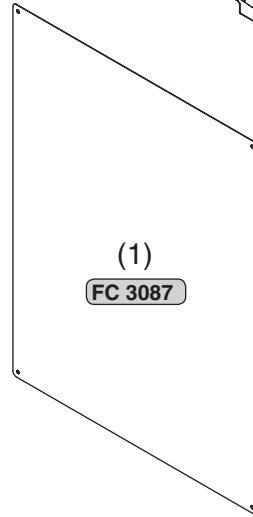

(1) FC 3087



(1) FC 3211



(1) FC 3212



(1) FC 3213



(1) FC 3214



(1) LT 7000

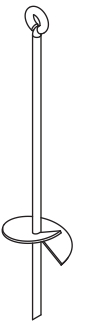

(7) FC 3217

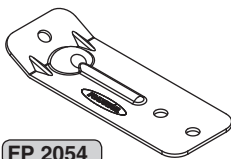

(1) FP 2054

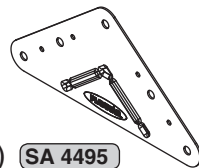

(2) SA 4495



(2) FC 3107



(2) FC 3106

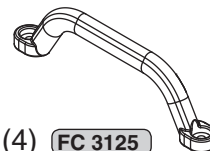

(4) FC 3125

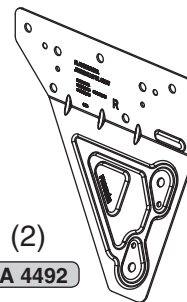

(2) SA 4492

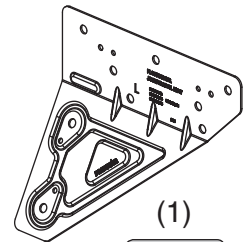

(1) SA 4493



(6) HW 1611

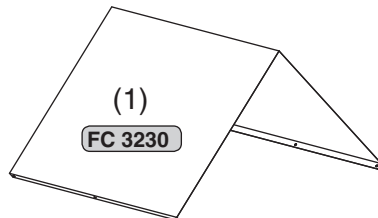

(1) FC 3230

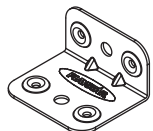

(24) SA 4496



(4) SA 4494

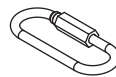

(10) HW 1600

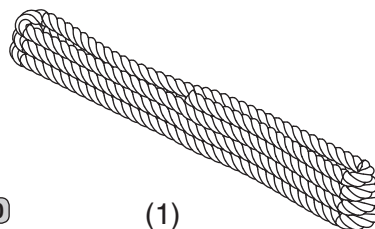

(1) FC 3210

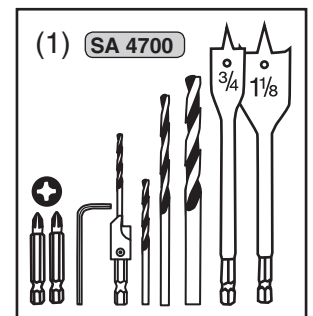

(1) SA 4700

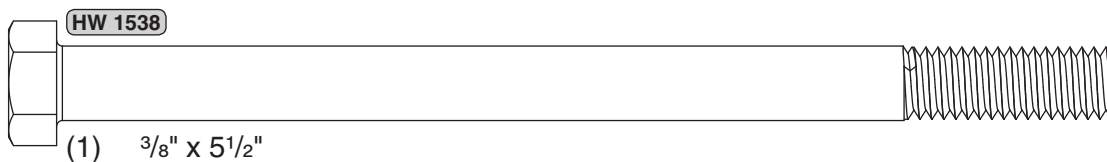
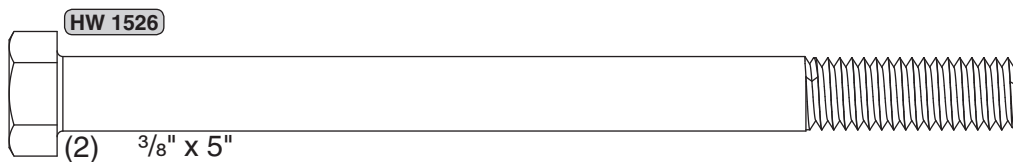
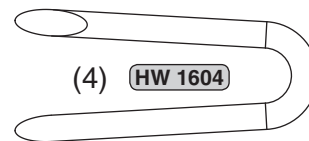
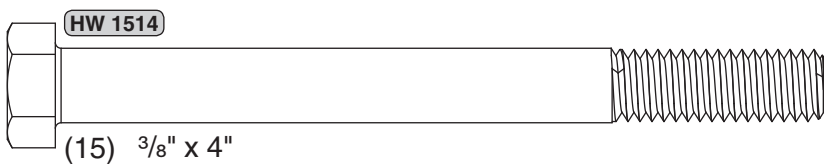
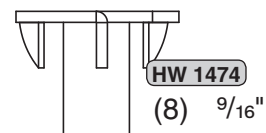
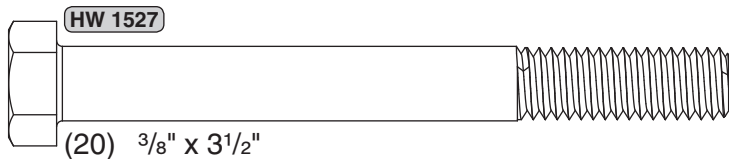
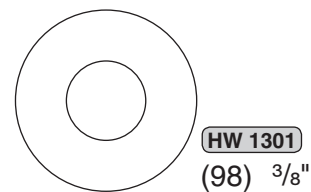
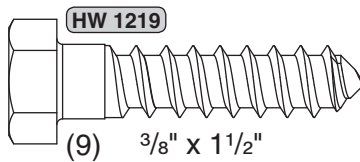
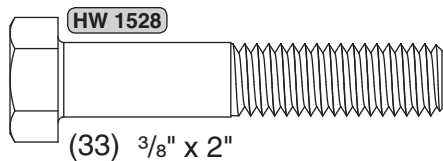
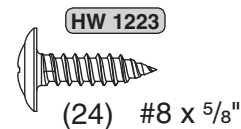
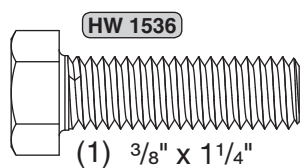
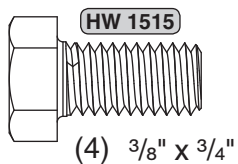
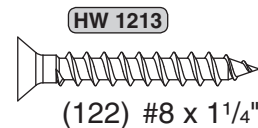
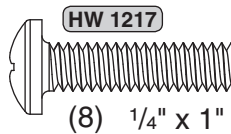
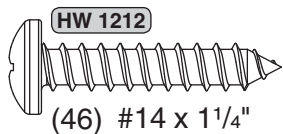
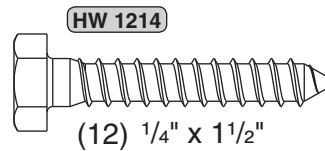
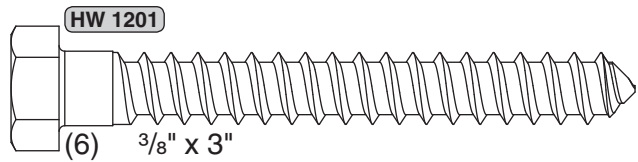
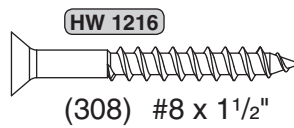
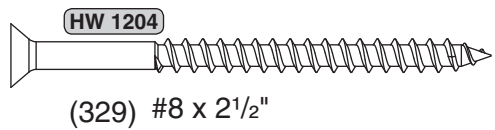
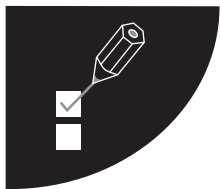

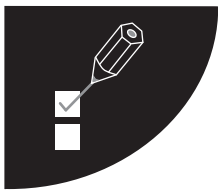

Lumber Notes:

- Boards are marked with nominal dimensions.
- Actual size may vary.
- Assembly is easier if boards are stacked by marked size before beginning.
- During assembly process, hide the dimension mark to the inside.
- If 1" thick boards are not pre-drilled & countersunk, it is easier to complete using drill marking template before beginning the assembly process.
- 2" thick boards will be drilled during assembly process using drill marking template.
- Always use any pre-drilled boards as the drill template to drill 1" into second board before securing with hardware or screws.
- Lumber is a natural product. Imperfections are normal. Minor bowing can be straightened and imperfection hidden during assembly.



F **F**
(2) 1" x 4" x 12"

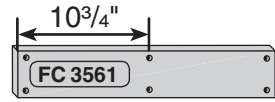

F **G** **F**
(29) 1" x 4" x 21⁷/₁₆"



F **F**
(19) 1" x 4" x 29¹/₂"

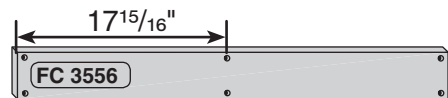

F **G** **F**
(9) 1" x 4" x 35⁷/₈"

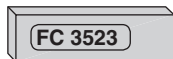
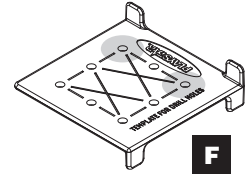
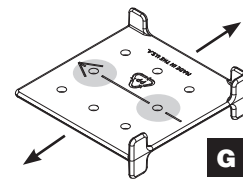

(5) 2" x 4" x 13¹/₈"



(1) 2" x 4" x 18¹/₂"



(2) 2" x 4" x 21¹/₂"



(2) 2" x 4" x 24¹/₄"



(22) 2" x 4" x 28¹/₂"



(8) 2" x 4" x 31¹/₂"

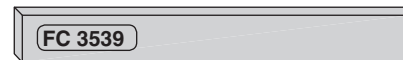

(1) 2" x 4" x 32¹/₂"



(1) 2" x 4" x 35⁷/₈"

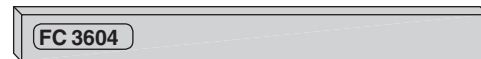

(17) 2" x 4" x 39"



(2) 2" x 4" x 42¹/₄"

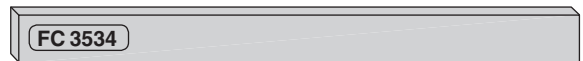

(12) 2" x 4" x 46³/₄"

Post & Beam Lumber (Purchased Separately)



(3) 4" x 4" x 8'



(2) 2" x 6" x 10'



(8) 2" x 4" x 8'

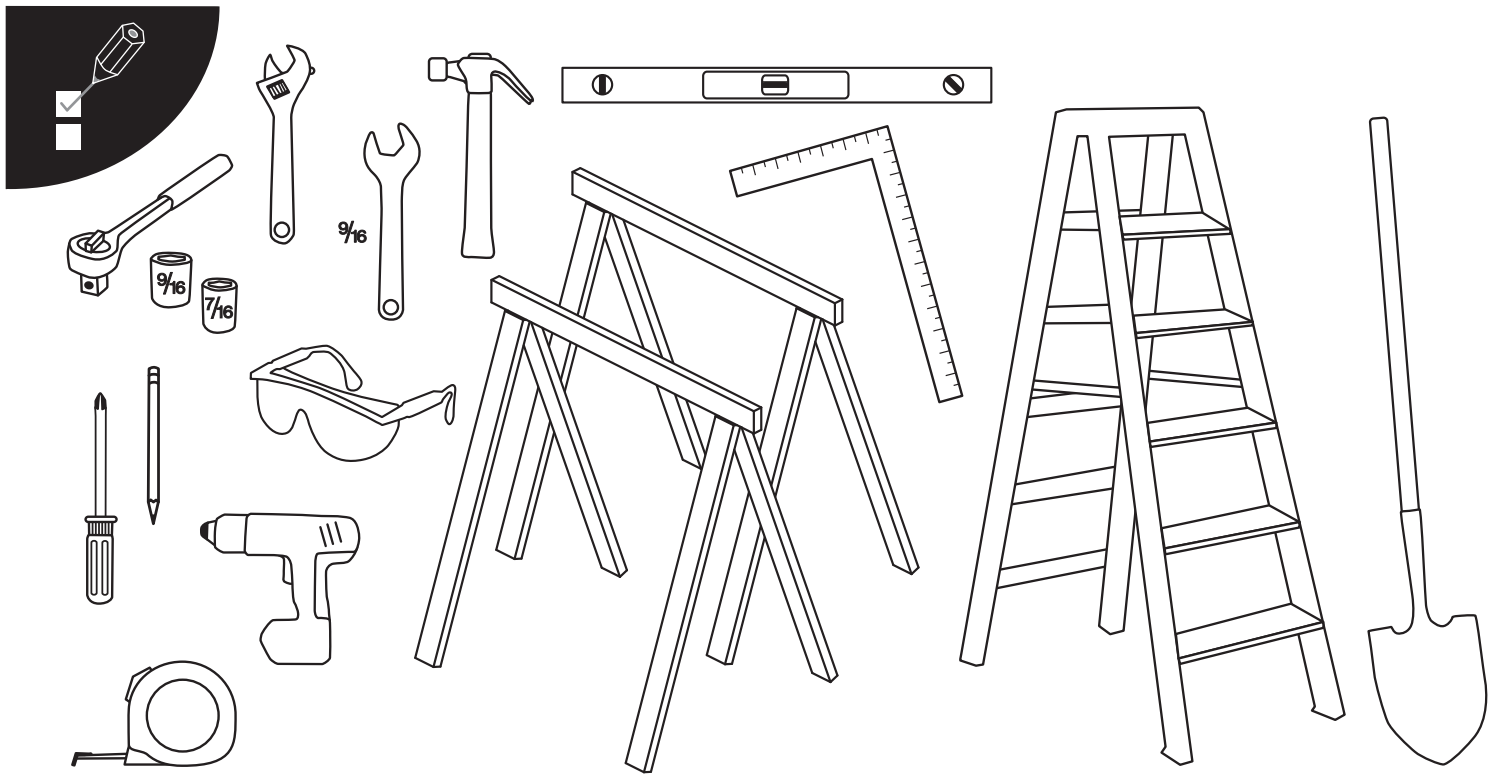

Icon Glossary

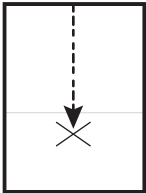

Place tower or component in desired location.

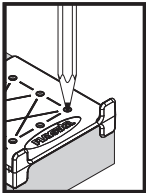

Mark board with template using pattern shown on this step.
Note: DO NOT drill through template.

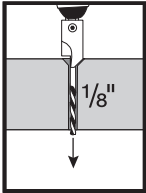

Drill through board at correct location with countersink tool and bit size shown.

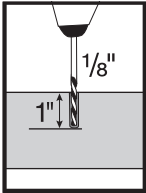

Drill down the depth shown into board at correct locations using bit size shown.
Note: You may use any bracket as a drill template.

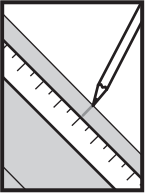

Mark board with measurement shown for location on this step.

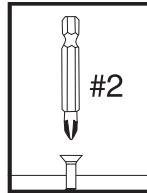

Secure screw (flush to top) with bit size shown.

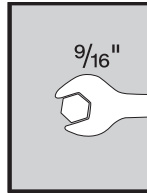

Secure hardware with socket/wrench size shown.

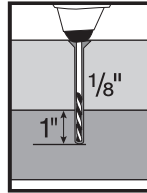

Pre-drill into second board with correct depth and bit size shown.
Note: Use pre-drilled & countersunk board as template.

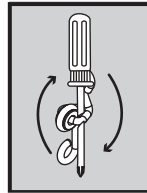

Screw hardware into board or ground using shaft of screwdriver for better leverage.

Icons are used throughout instructions to indicate process for each step.

Safety Warning Glossary

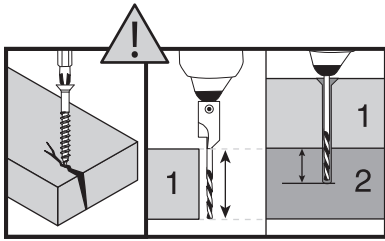

CAUTION: These boards should be pre-drilled and countersunk to avoid cracking. **Note: Adjust countersink tool to width of first board to countersink to proper depth. Pre-drill into second board using first board as a template before attaching.**

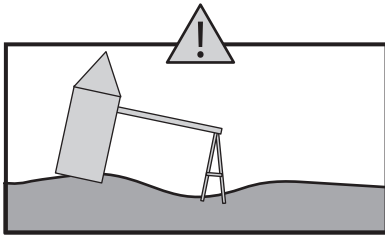

CAUTION: Ground must be level. Installation on a hill or incline will create unsafe conditions.

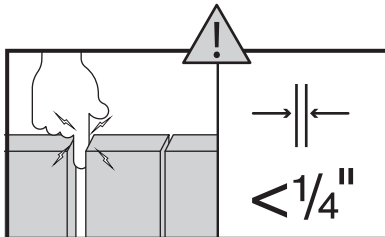

CAUTION: Spacing between boards must be less than 1/4" or a finger entrapment could exist.

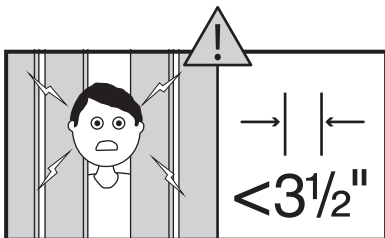

CAUTION: Spacing between boards must be less than 3 1/2" (or greater than 9") or a head/neck entrapment could exist.

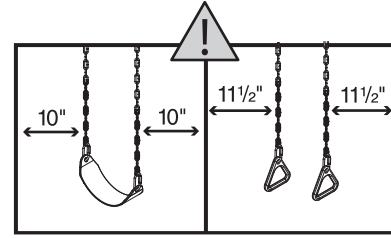

CAUTION: Minimum spacing is required from the closest point of all other rides or stationary objects.

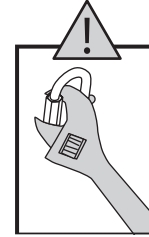

CAUTION: Use wrench to tighten Quick-Link Connectors. Failure to tighten Quick-Links securely could result in injury.

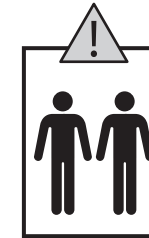

CAUTION: Use two people to rotate, lift or support structure at this step to avoid injury to yourself or bending of brackets.

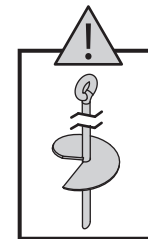

CAUTION: Failure to anchor properly could cause serious injury. Anchors must be placed below the level of the shock-absorbing surfacing material to prevent tripping or injury resulting from a fall. Refer to the Safety Guidelines at the beginning of this plan. **Note: If soil conditions permit anchors to be pulled out easily, such as in sandy soil conditions, cementing is required. If your ground is too hard to screw in the anchors you can remove the earth with a shovel. Install the anchors and compact the earth as you replace it.**

Helpful Hints



Make sure boards remain square. **Note: Assembly process should take place on flat surface.**



This helps with assembly process.



Do not _____.

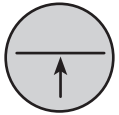

Be sure boards are flush.



Be sure boards/brackets are tight against each other.

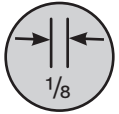

Be sure boards are spaced the distance listed.

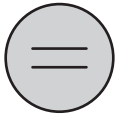

Be sure to equally space.



Be sure boards rest on the ground.

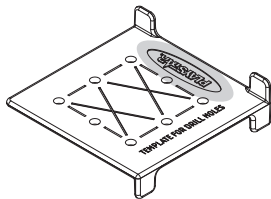

Playstar Logo showing:

Use tabs to square on corner of board.

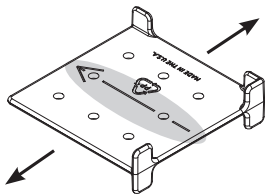

Arrow showing:

Use tabs to slide along edge of board to drill location.

There is a rigid version of this template in hardware bag. Use **only** to **mark** boards. **Do not drill** through template.

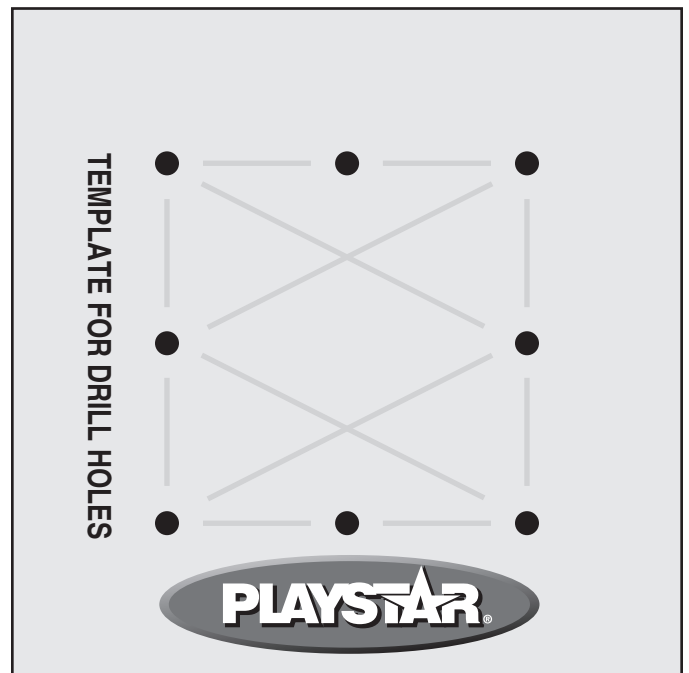

This page left blank intentionally.

Tower

1

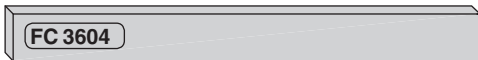
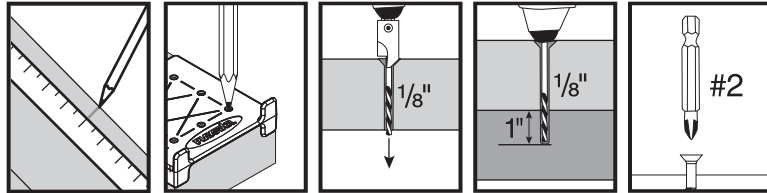
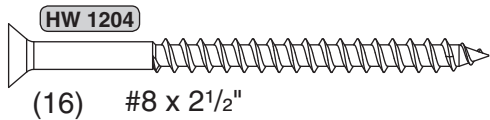

(4) 2" x 4" x 39"

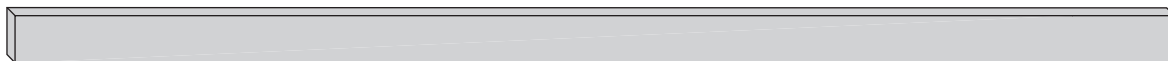

(2) 2" x 4" x 8'

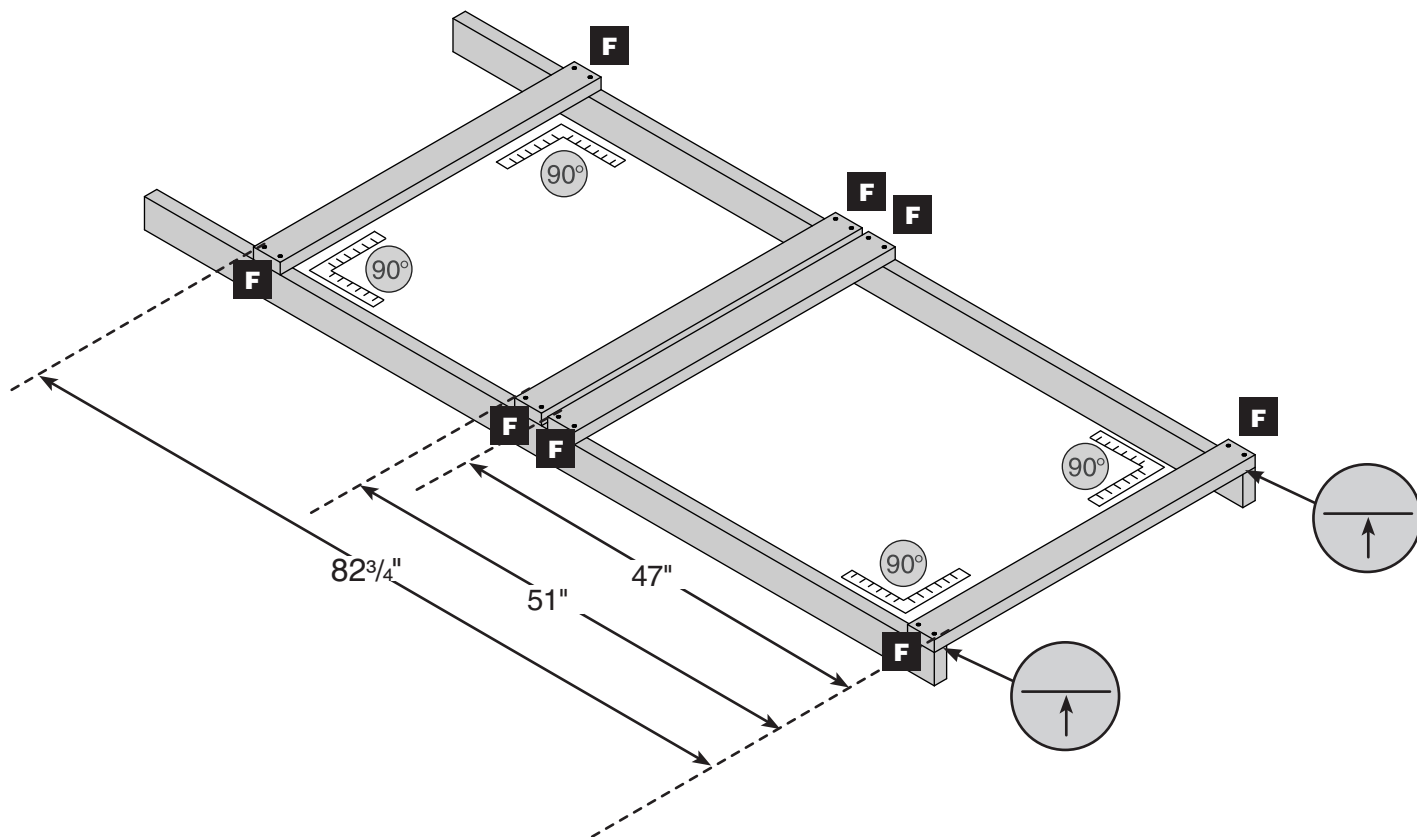
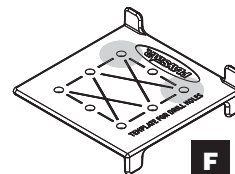

2

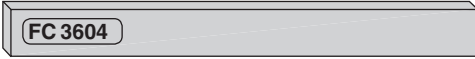
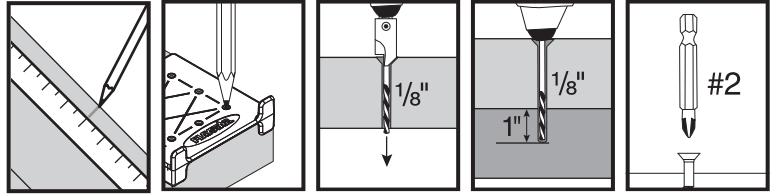
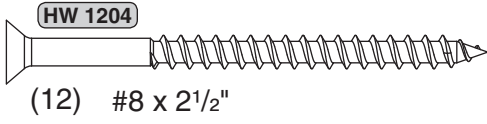

(3) 2" x 4" x 39"

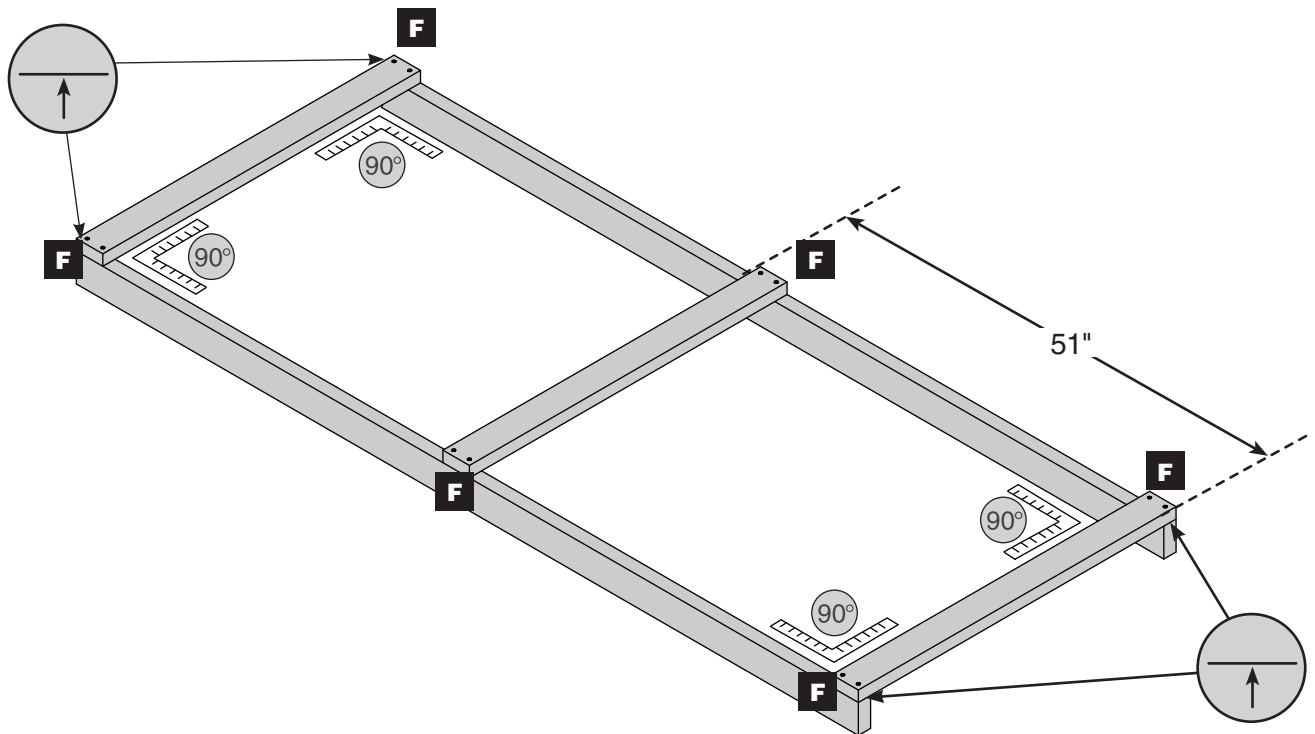
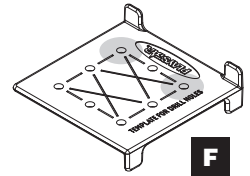
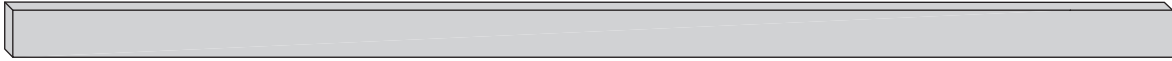

4

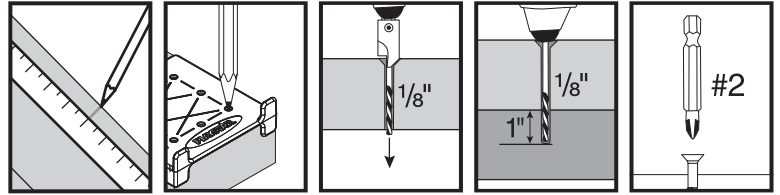
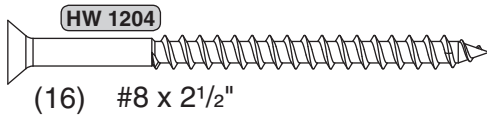

(4) 2" x 4" x 39"



(2) 2" x 4" x 8'

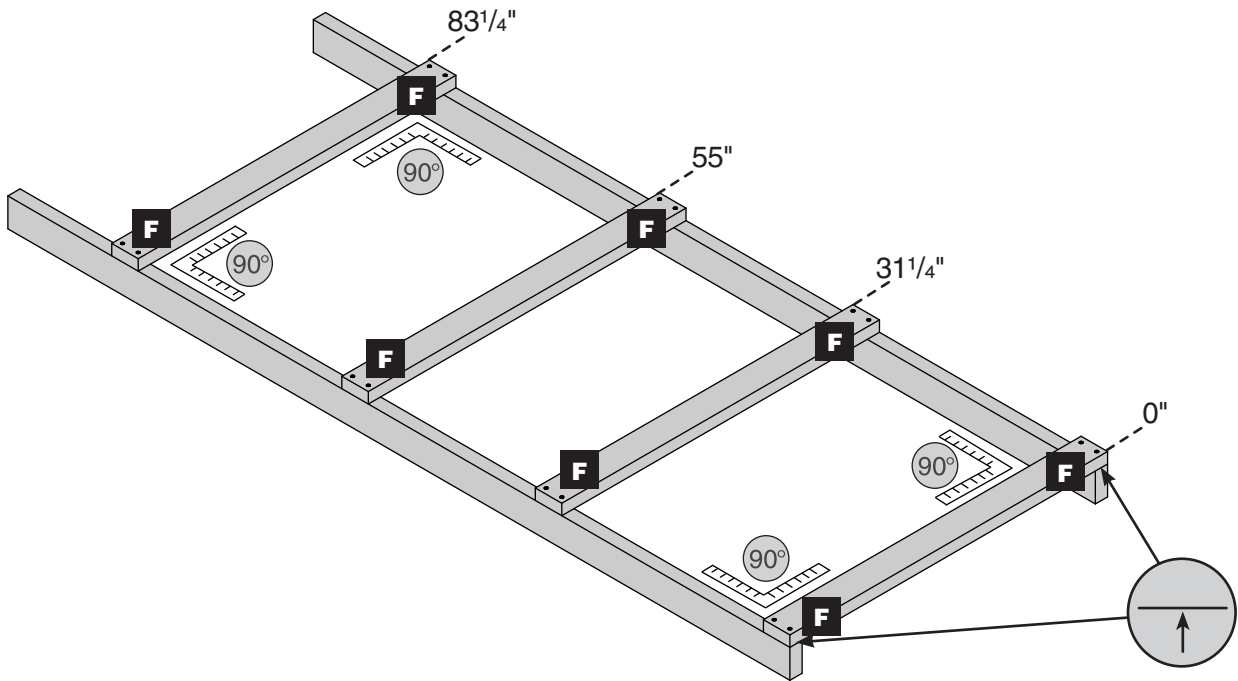
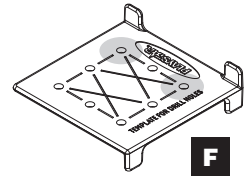

5

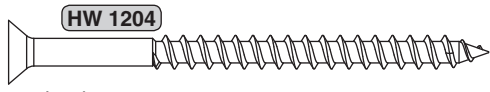

(34) #8 x 2 1/2"



(6) 2" x 4" x 28 1/2"

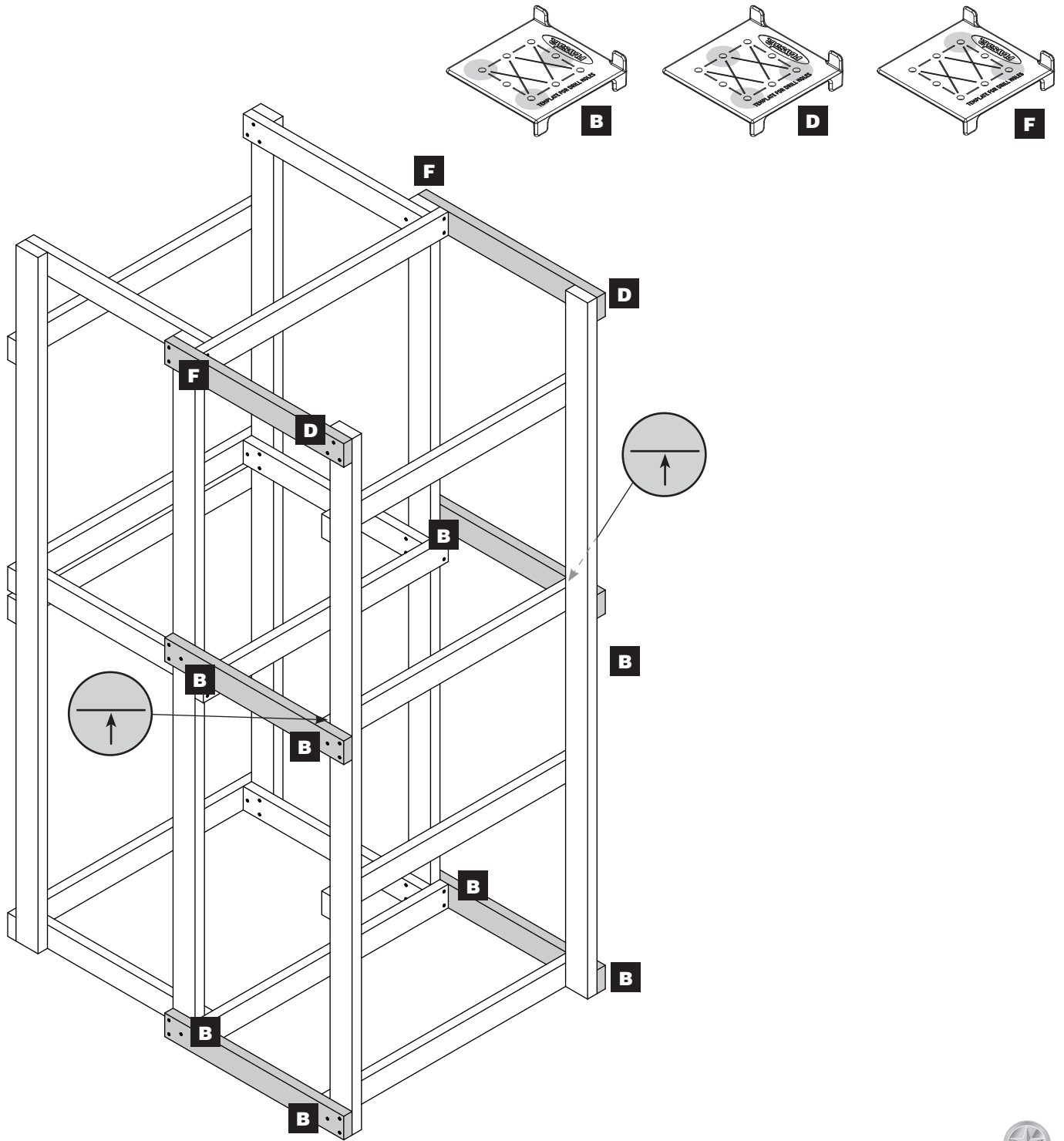
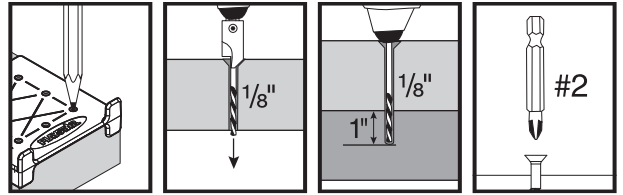

6

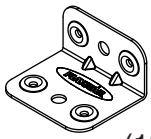

(12)

SA 4496

HW 1213

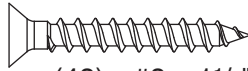

(48) #8 x 1 1/4"

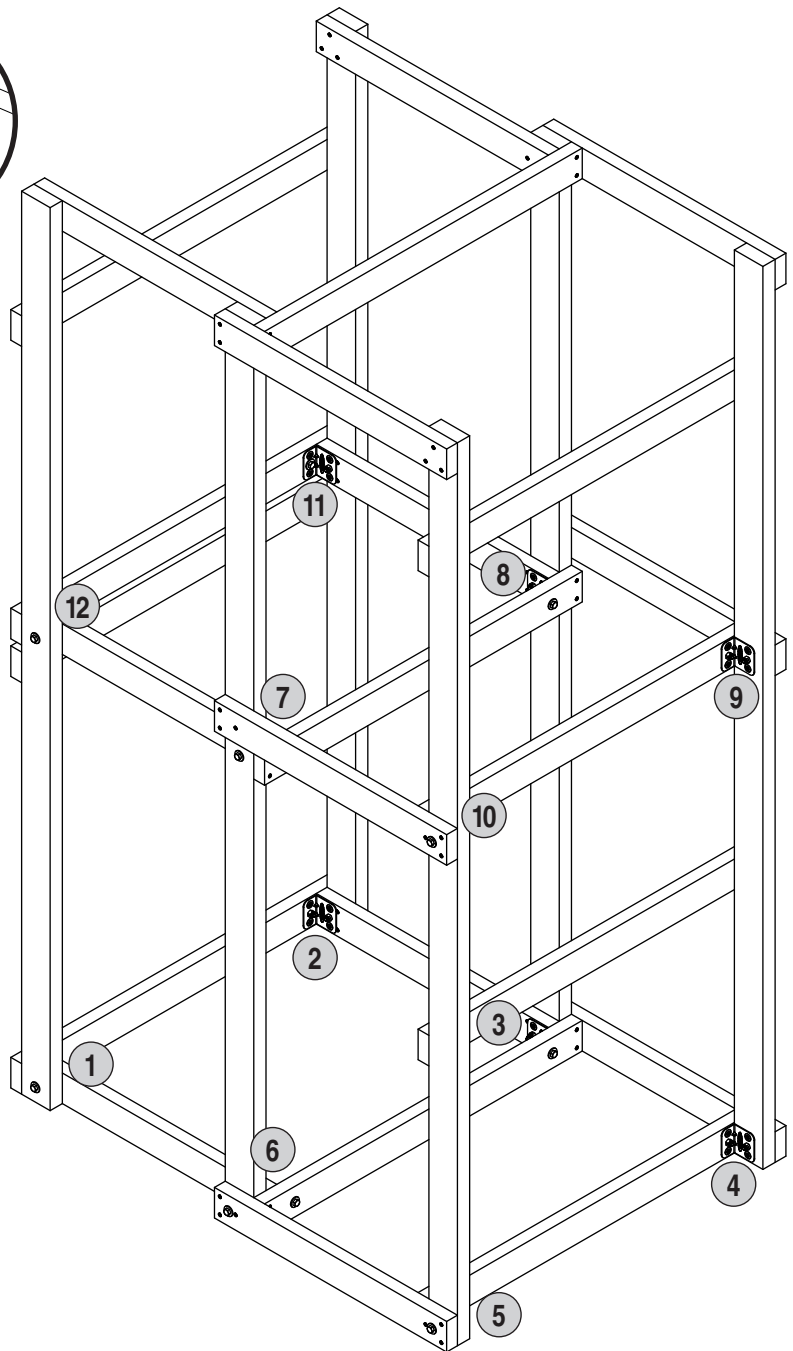
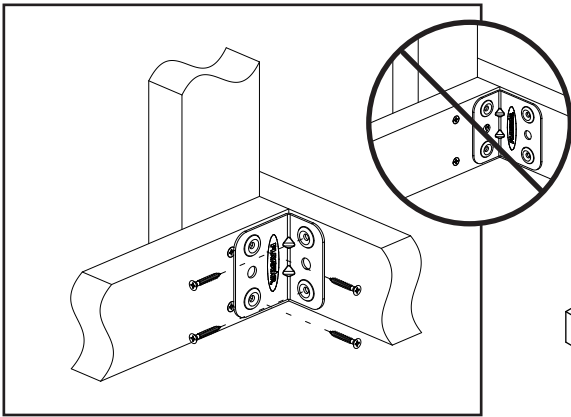
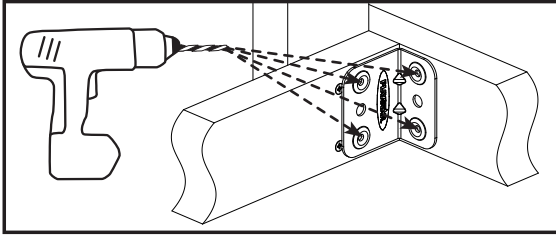
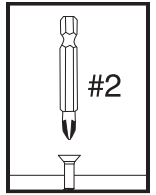
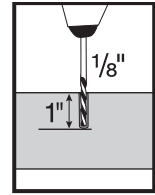

7

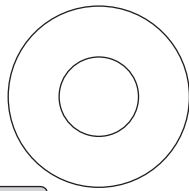

HW 1301
(22) 3/8"

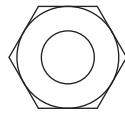

HW 1411
(22) 3/8"

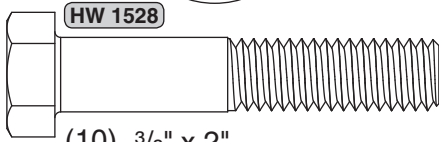
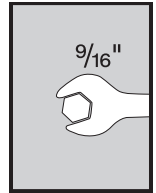
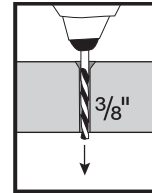

(10) 3/8" x 2"

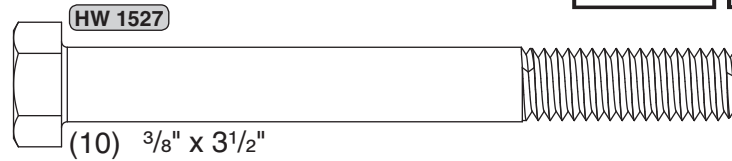

(10) 3/8" x 3 1/2"

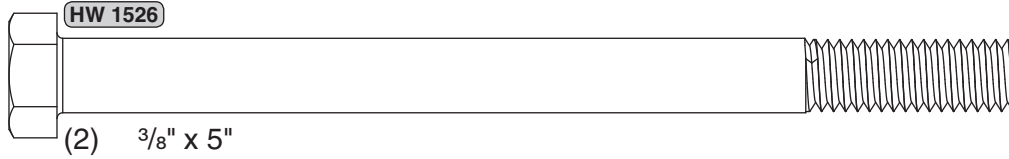

(2) 3/8" x 5"

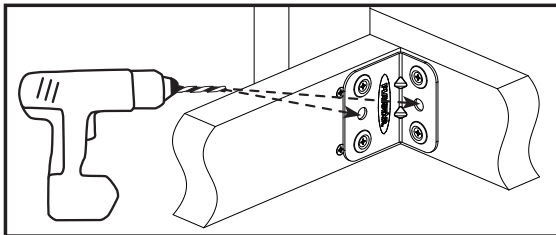

NOTE:

If you are bolting through one board use HW 1528

If you are bolting through two boards use HW 1527

If you are bolting through three boards use HW 1526

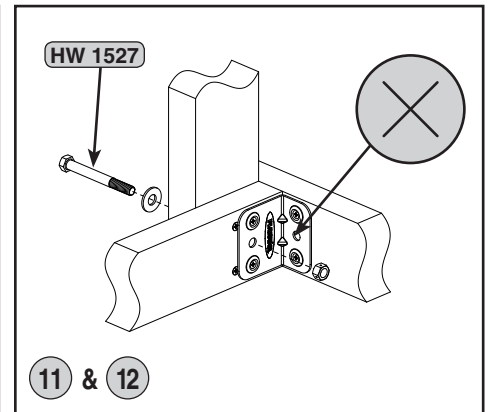
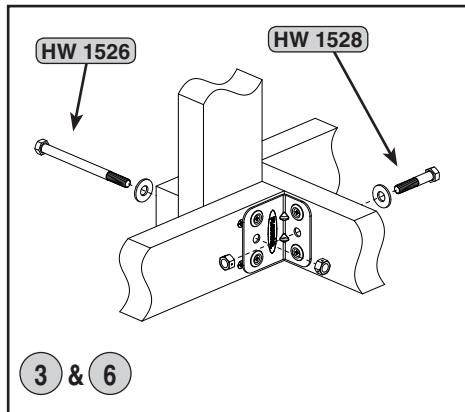
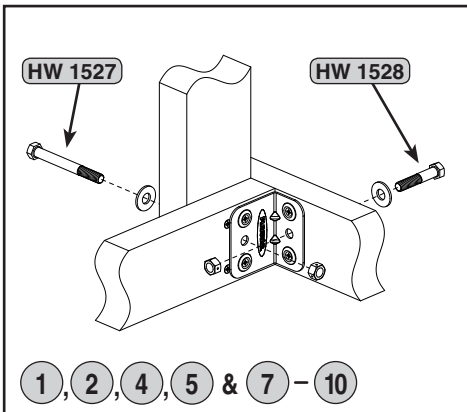

8

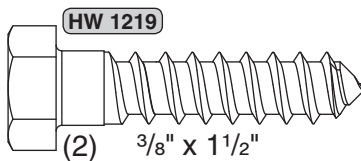

HW 1219
(2) 3/8" x 1 1/2"

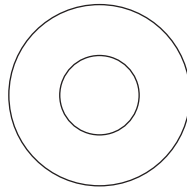

HW 1301
(2) 3/8"

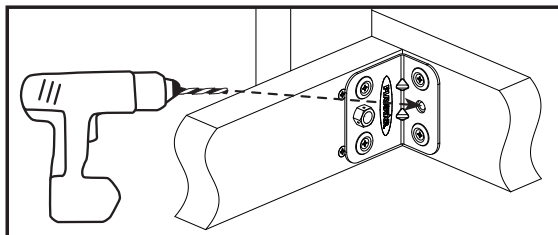
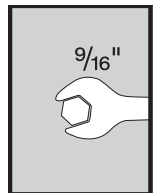
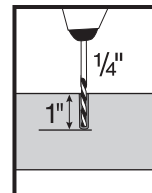

NOTE:

Brackets 11 & 12 use a 1/4" drill bit because you will be installing another board on the outer frame at a later step.

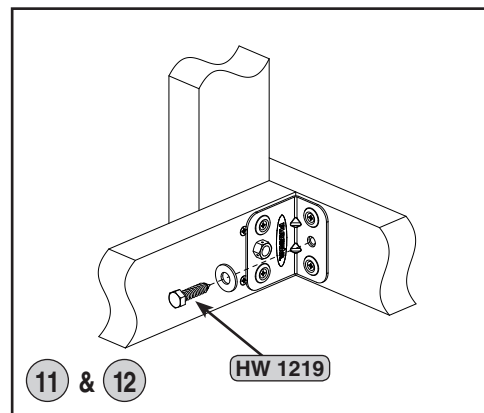

9

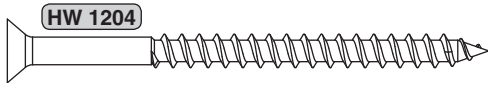

(4) #8 x 2 1/2"



(1) 2" x 4" x 28 1/2"

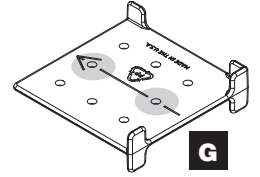
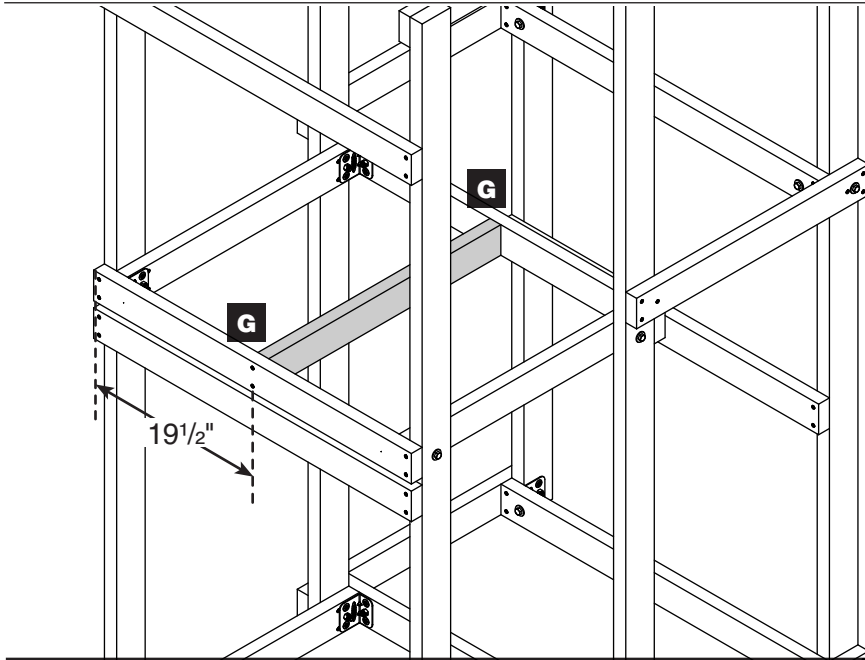
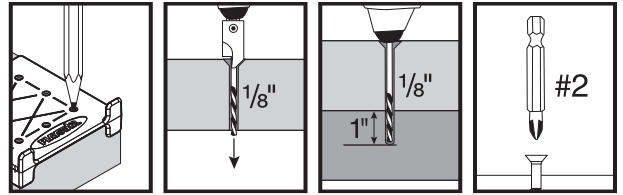

10

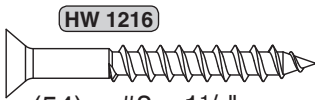

(54) #8 x 1 1/2"

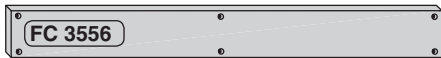

(9) 1" x 4" x 35 7/8"

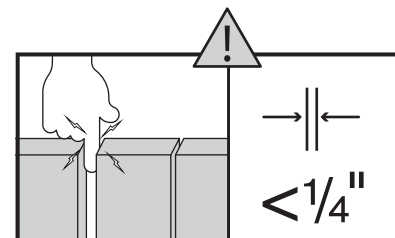
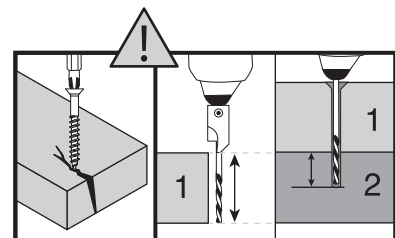
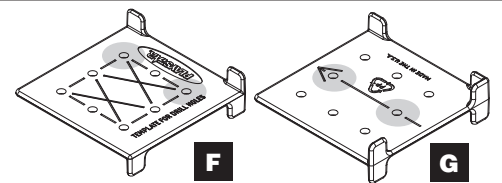
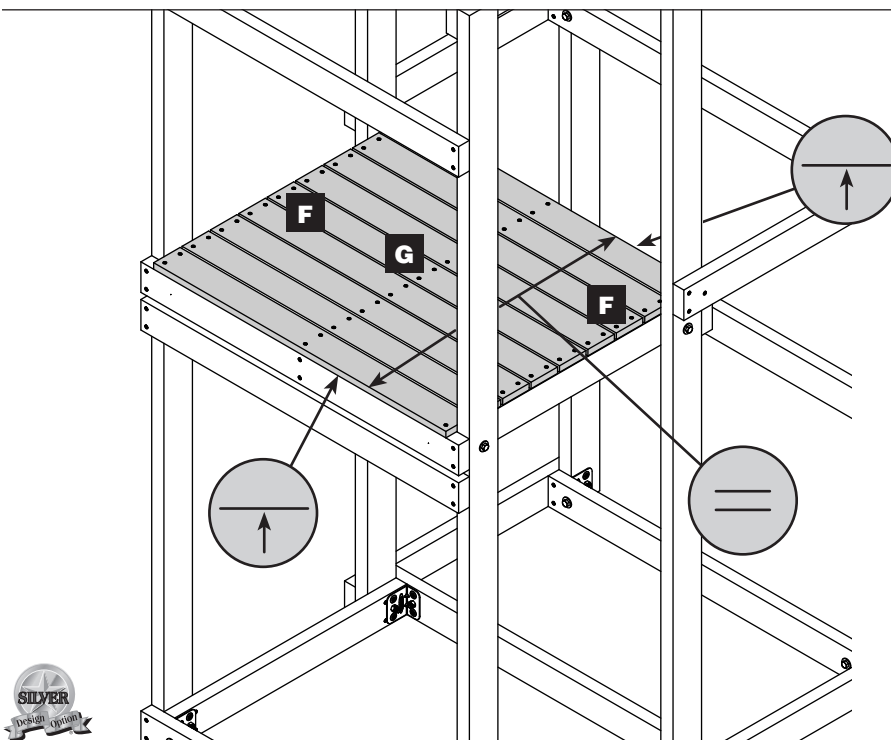
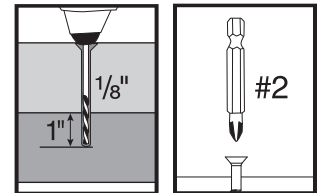

11

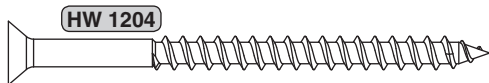

(8) #8 x 2 1/2"



(2) 2" x 4" x 39"

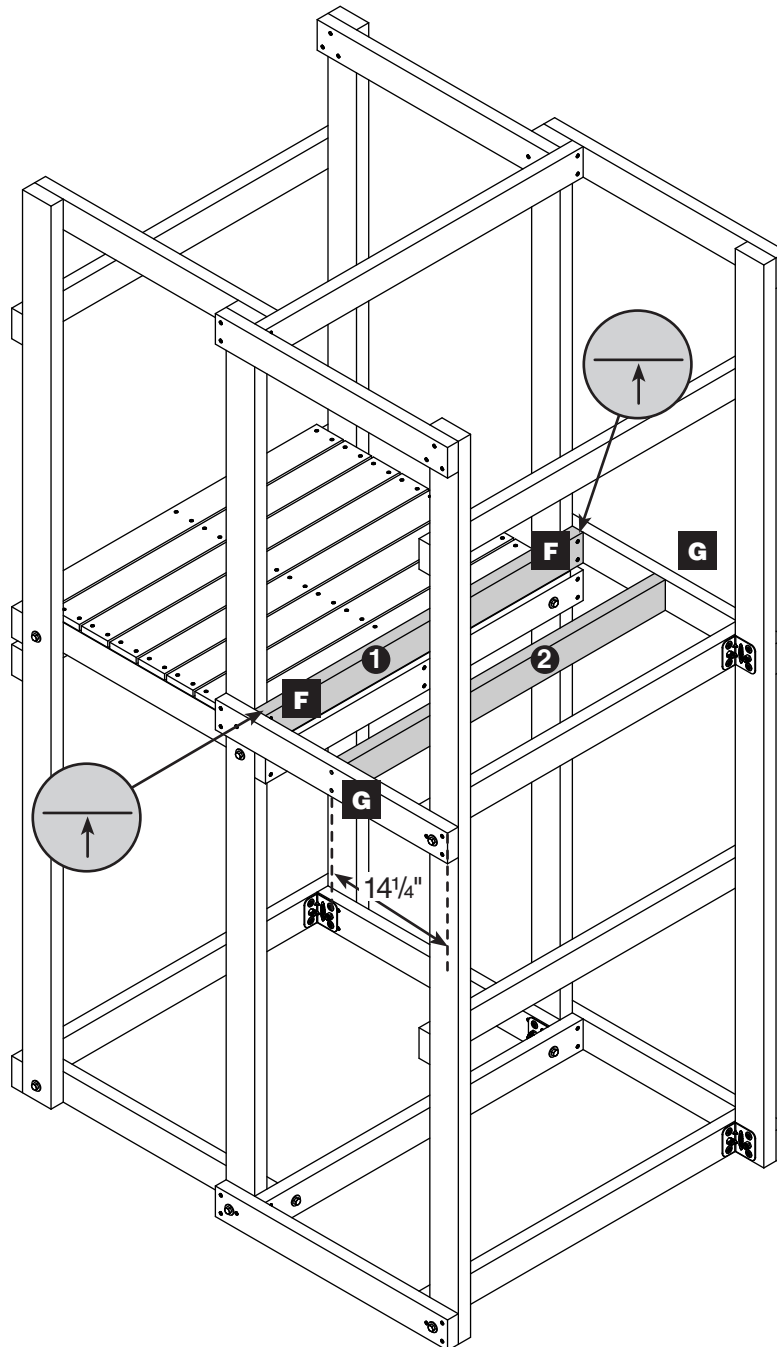
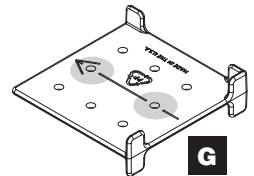
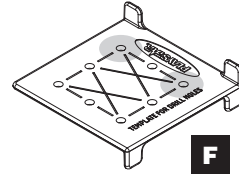
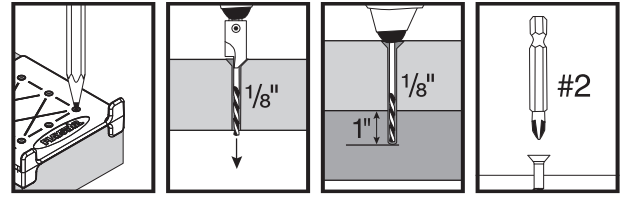

12

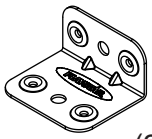

(2)
SA 4496

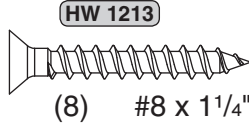

HW 1213

(8) #8 x 1 1/4"

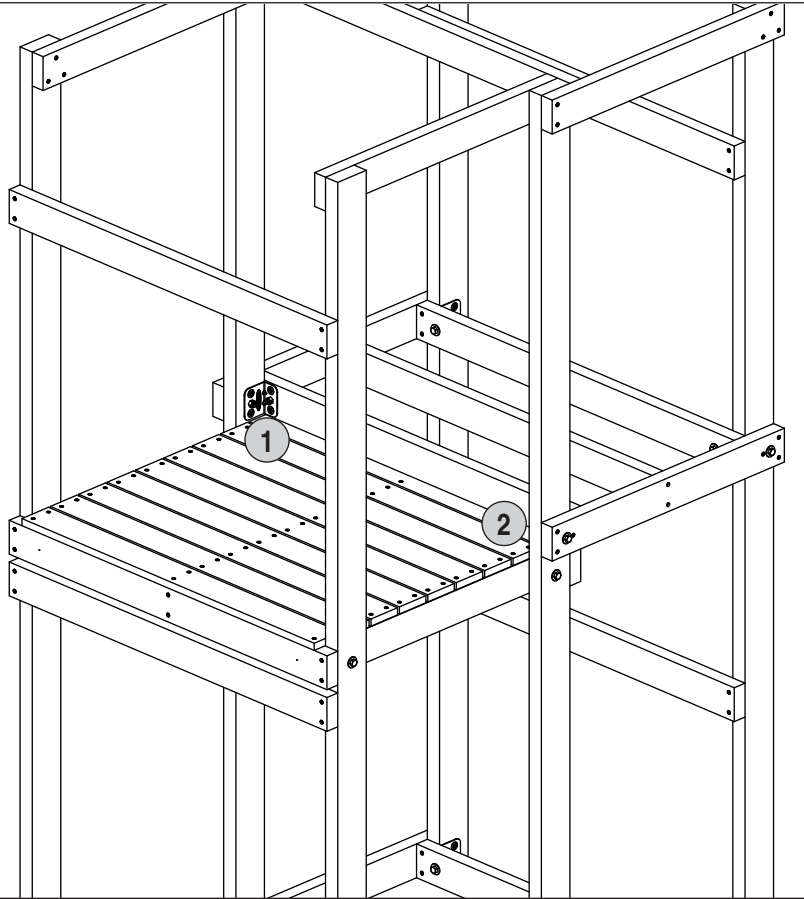
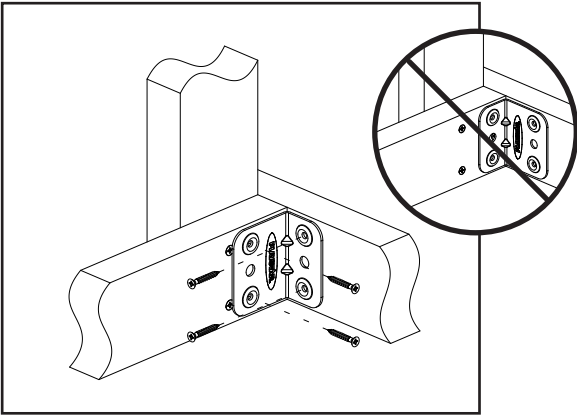
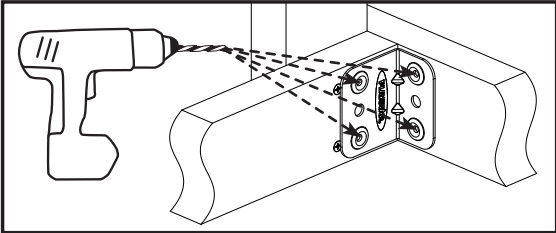
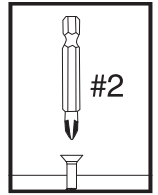
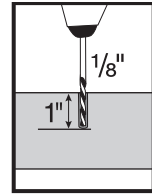

13

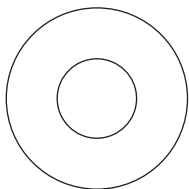

HW 1301
(4) 3/8"

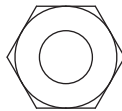

HW 1411
(4) 3/8"

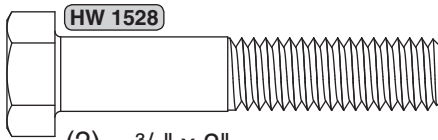
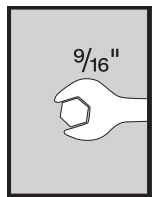
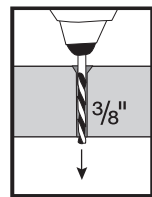

HW 1528
(2) 3/8" x 2"

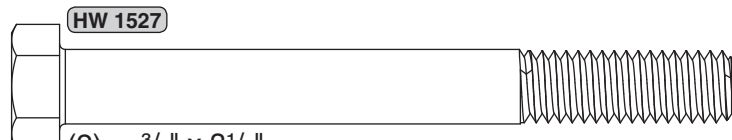

HW 1527
(2) 3/8" x 3 1/2"

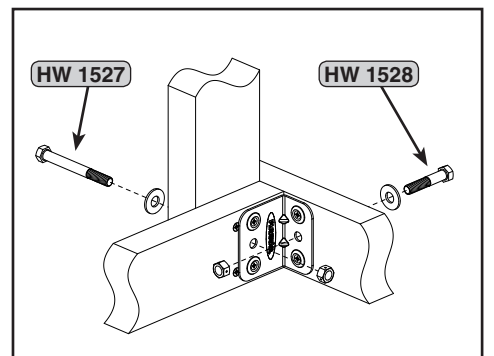
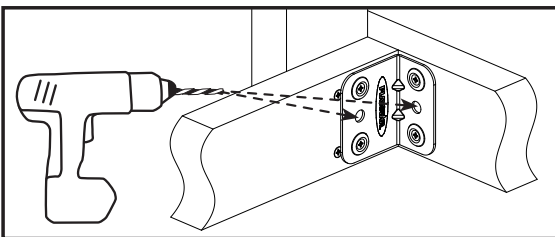

NOTE:

If you are bolting through one board use HW 1528
If you are bolting through two boards use HW 1527



14

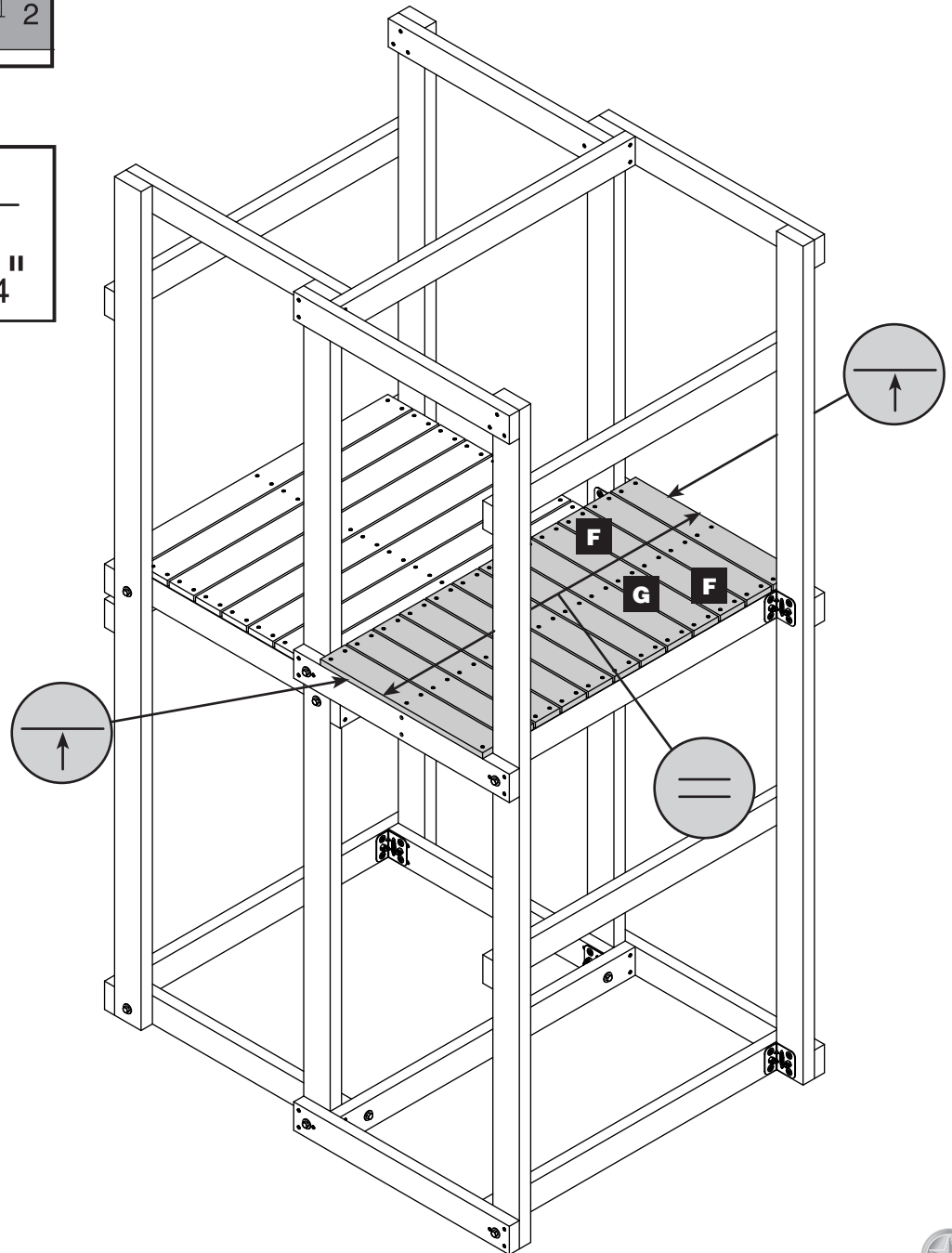
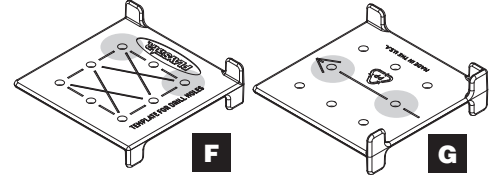
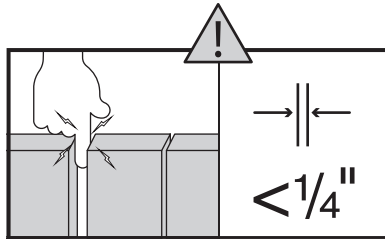
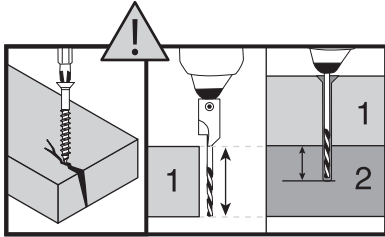
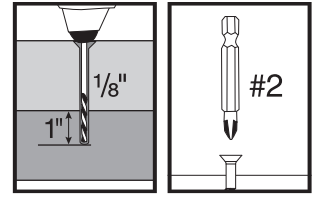
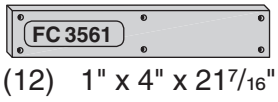
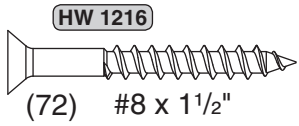

15

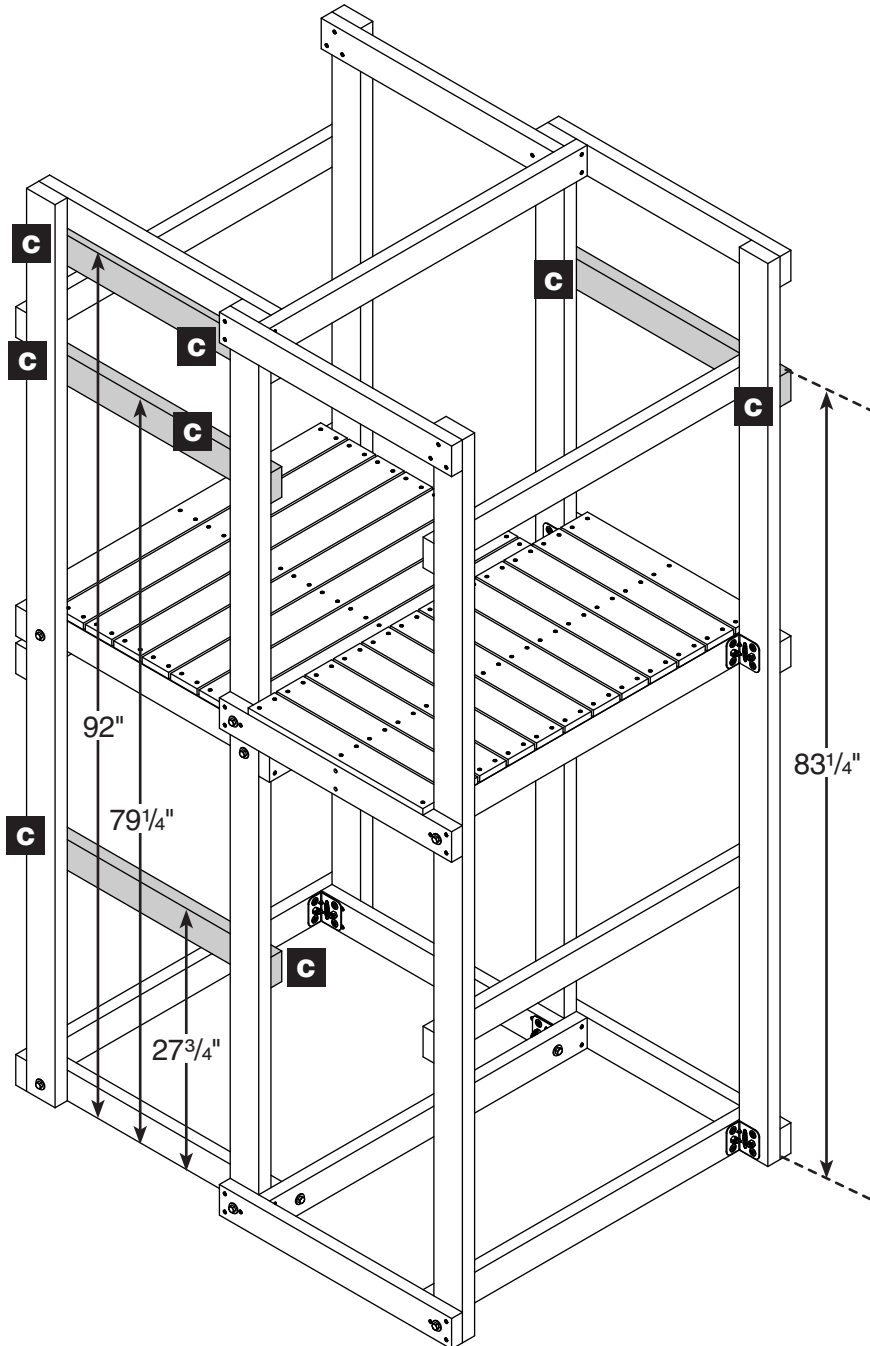
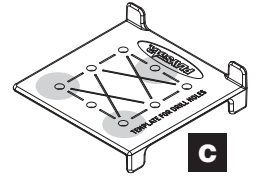
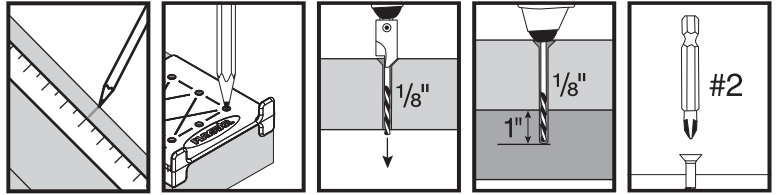
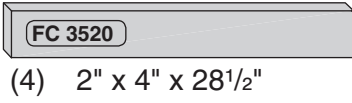
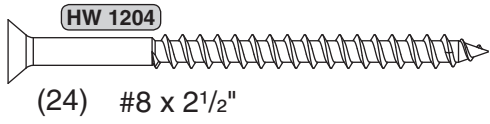

16

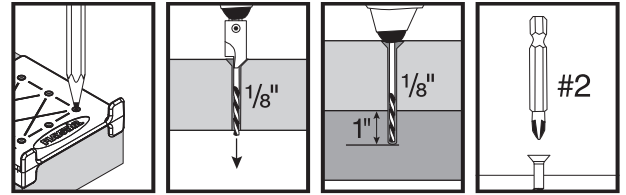
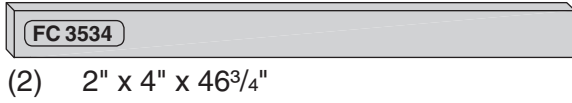
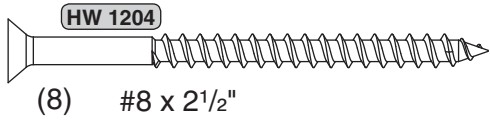

NOTE:
Be sure boards have equal overhang.

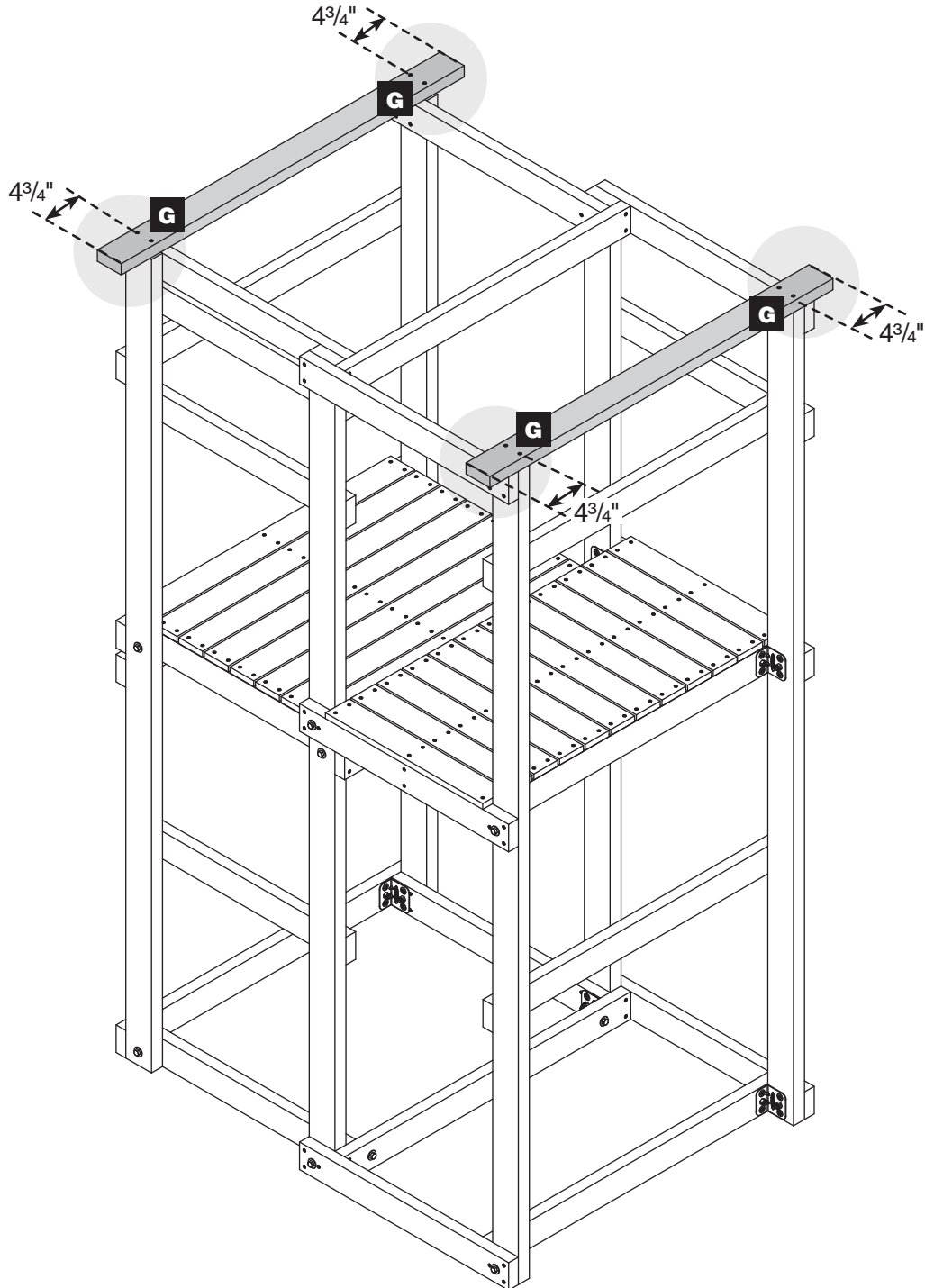
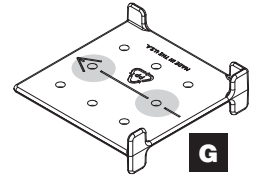

17

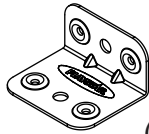

(4)

SA 4496

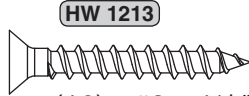

HW 1213

(16) #8 x 1 1/4"

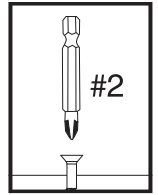
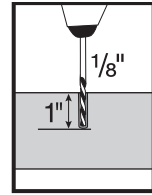

#2

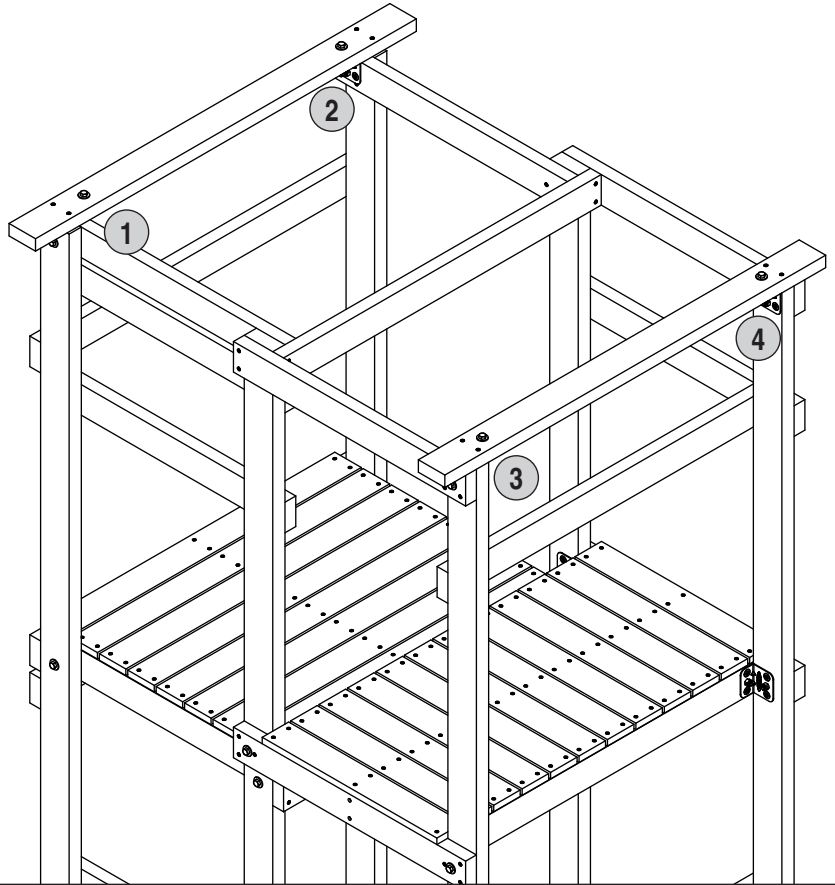
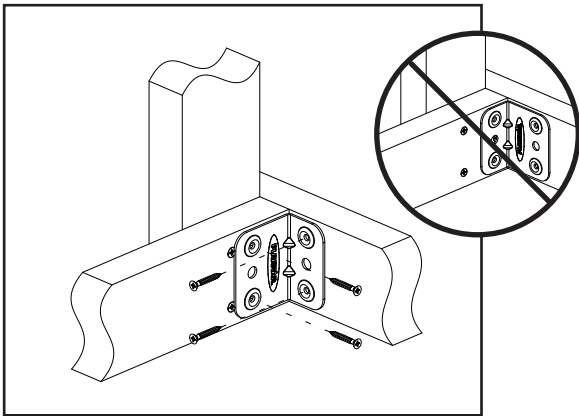
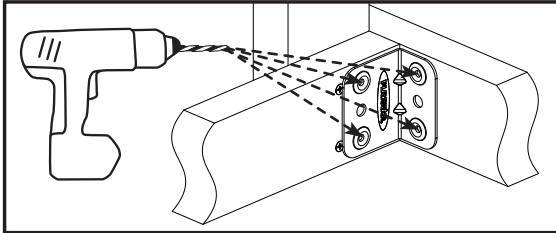

18

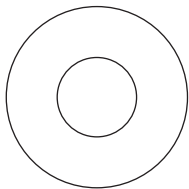

HW 1301

(8) 3/8"

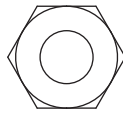

HW 1411

(8) 3/8"

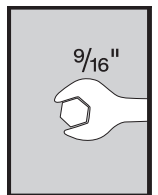
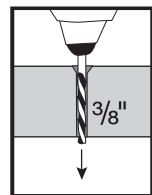

9/16"

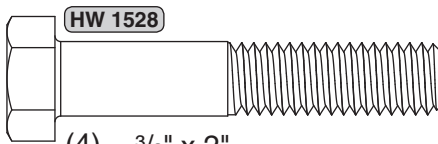

HW 1528

(4) 3/8" x 2"

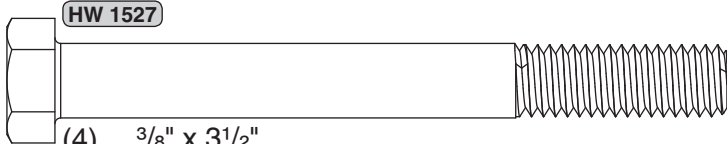

HW 1527

(4) 3/8" x 3 1/2"

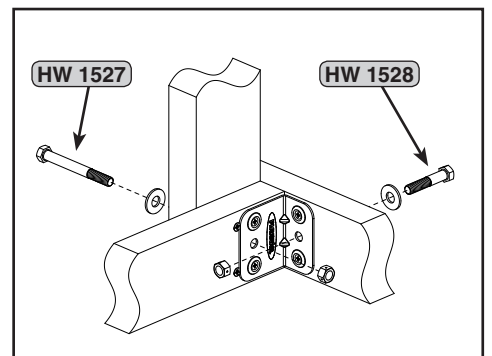
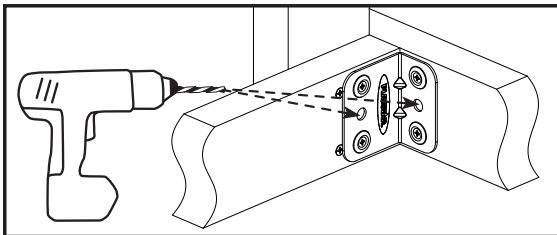

NOTE:

If you are bolting through one board use HW 1528

If you are bolting through two boards use HW 1527



19

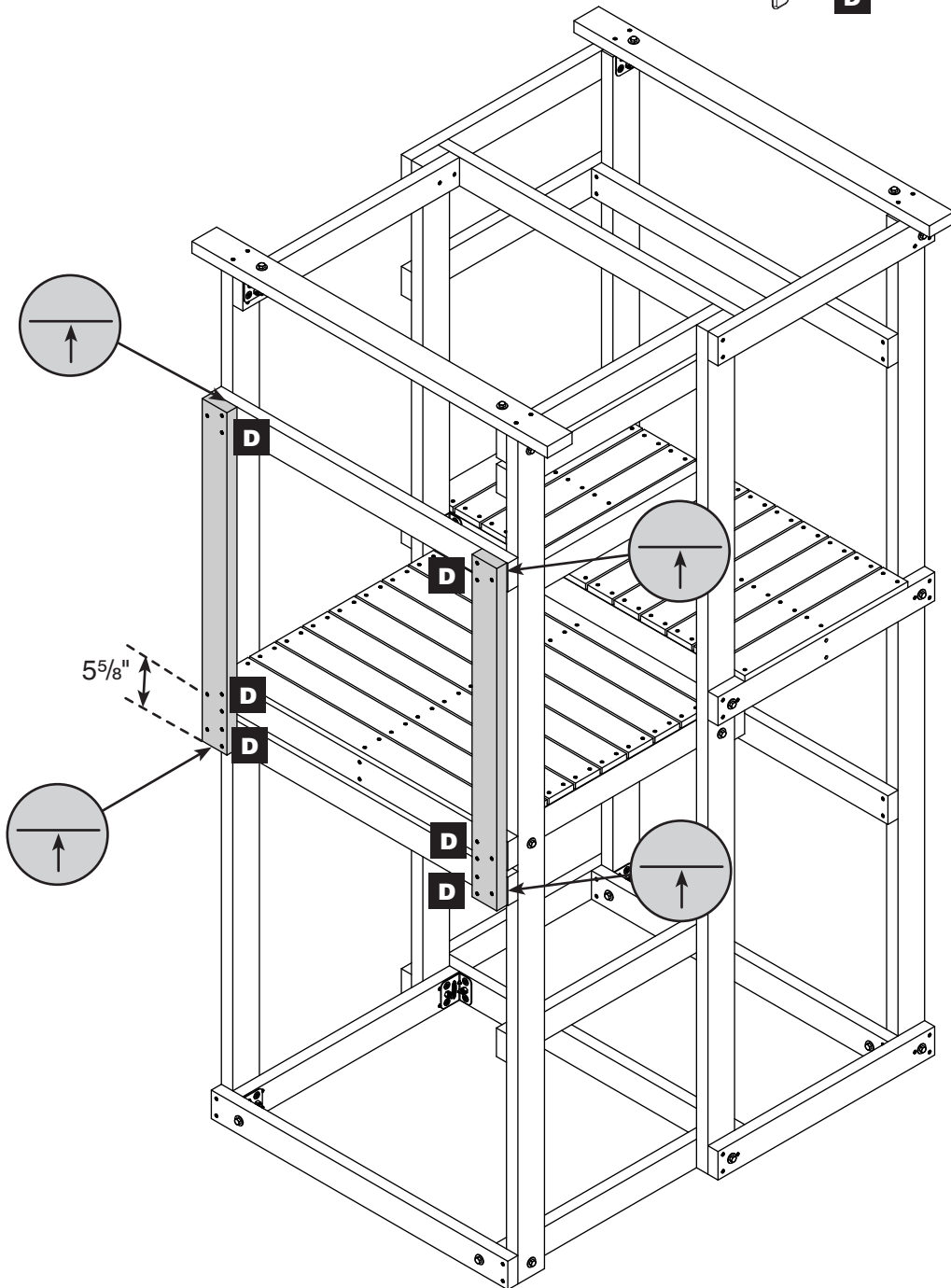
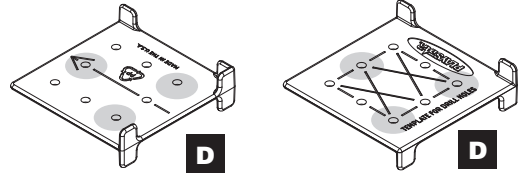
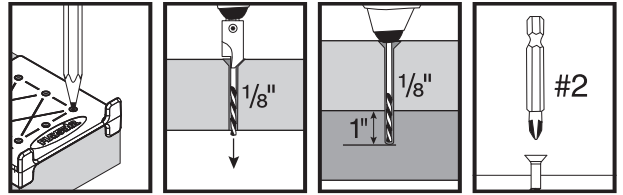
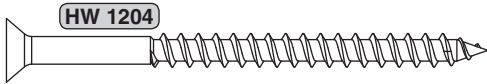

20

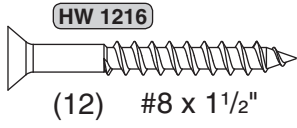

(3) 1" x 4" x 29 1/2"

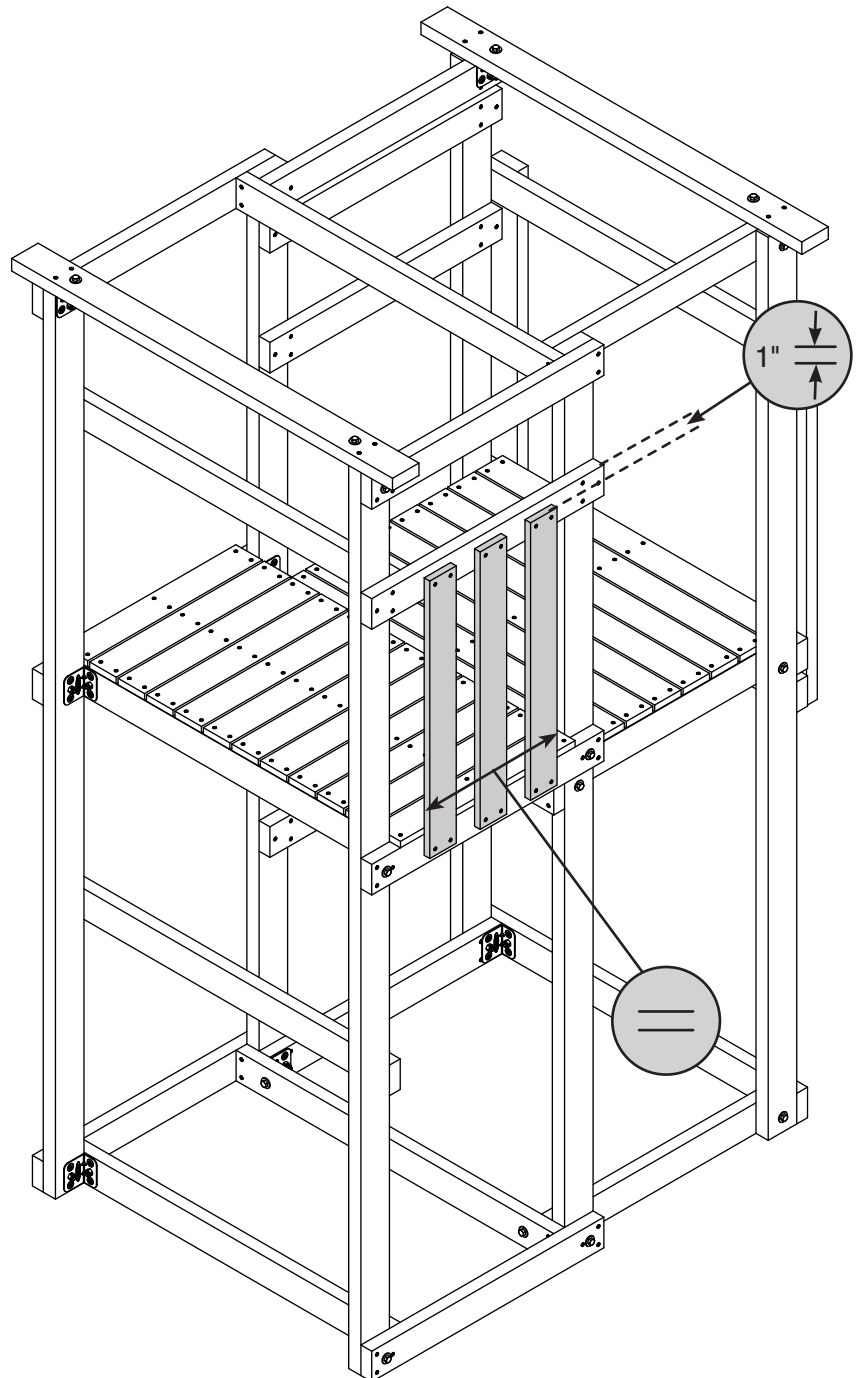
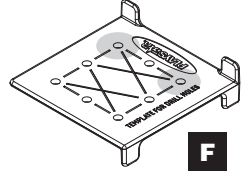
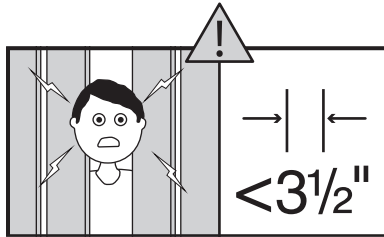
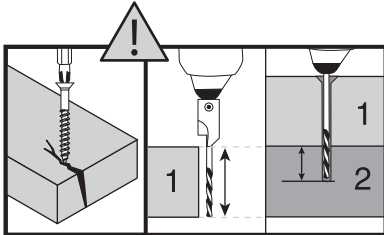
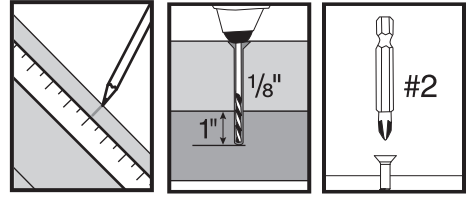

21

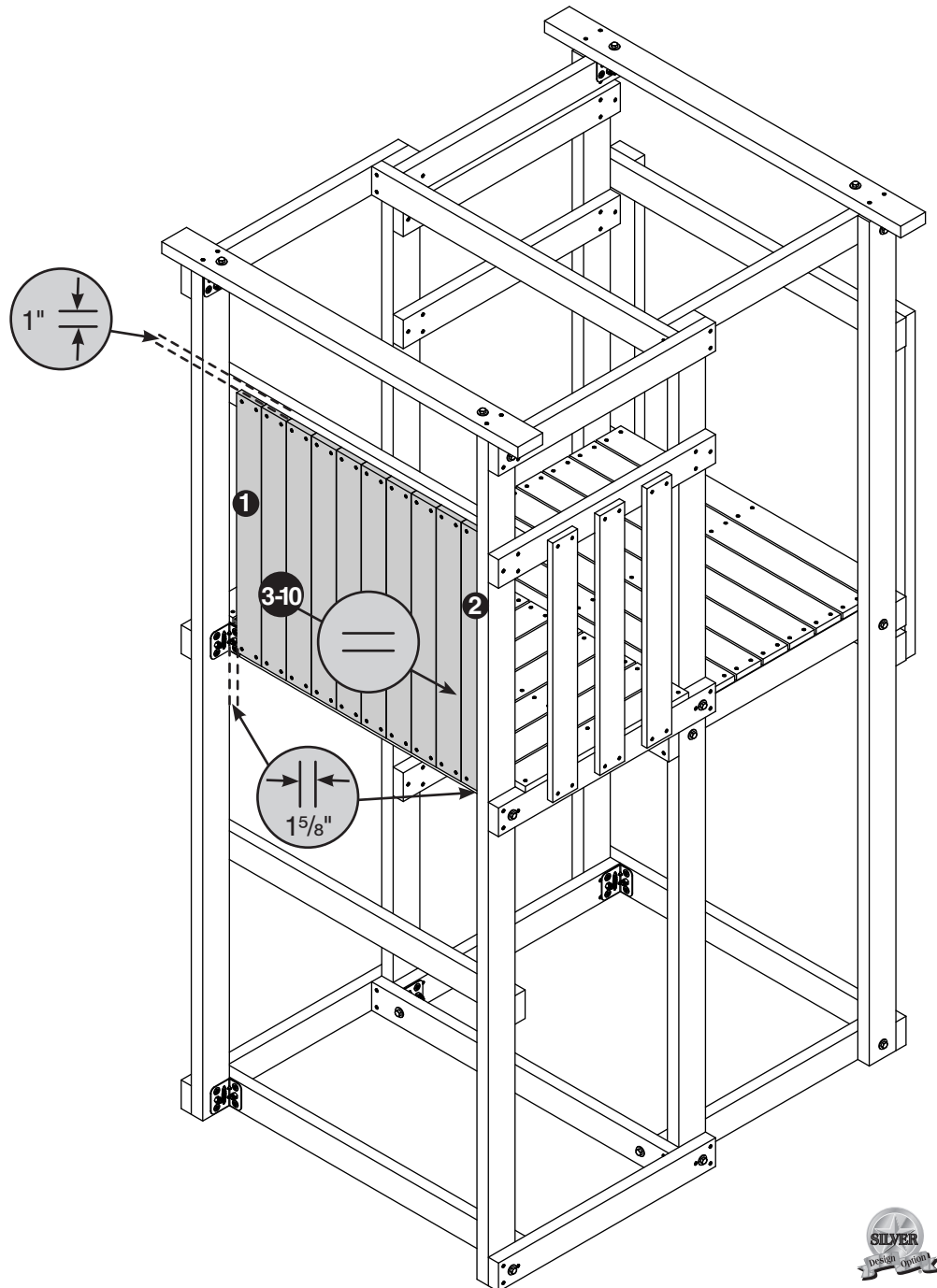
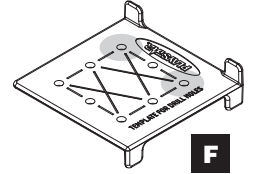
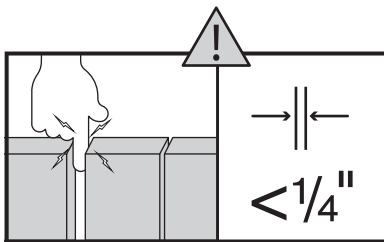
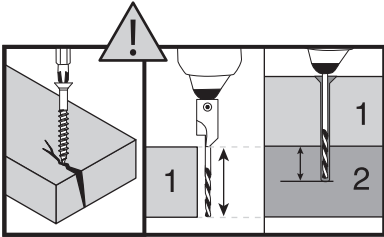
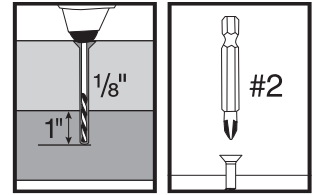
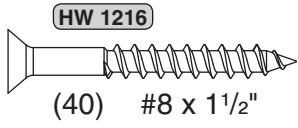

22

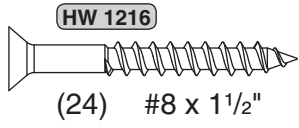

(6) 1" x 4" x 29 1/2"

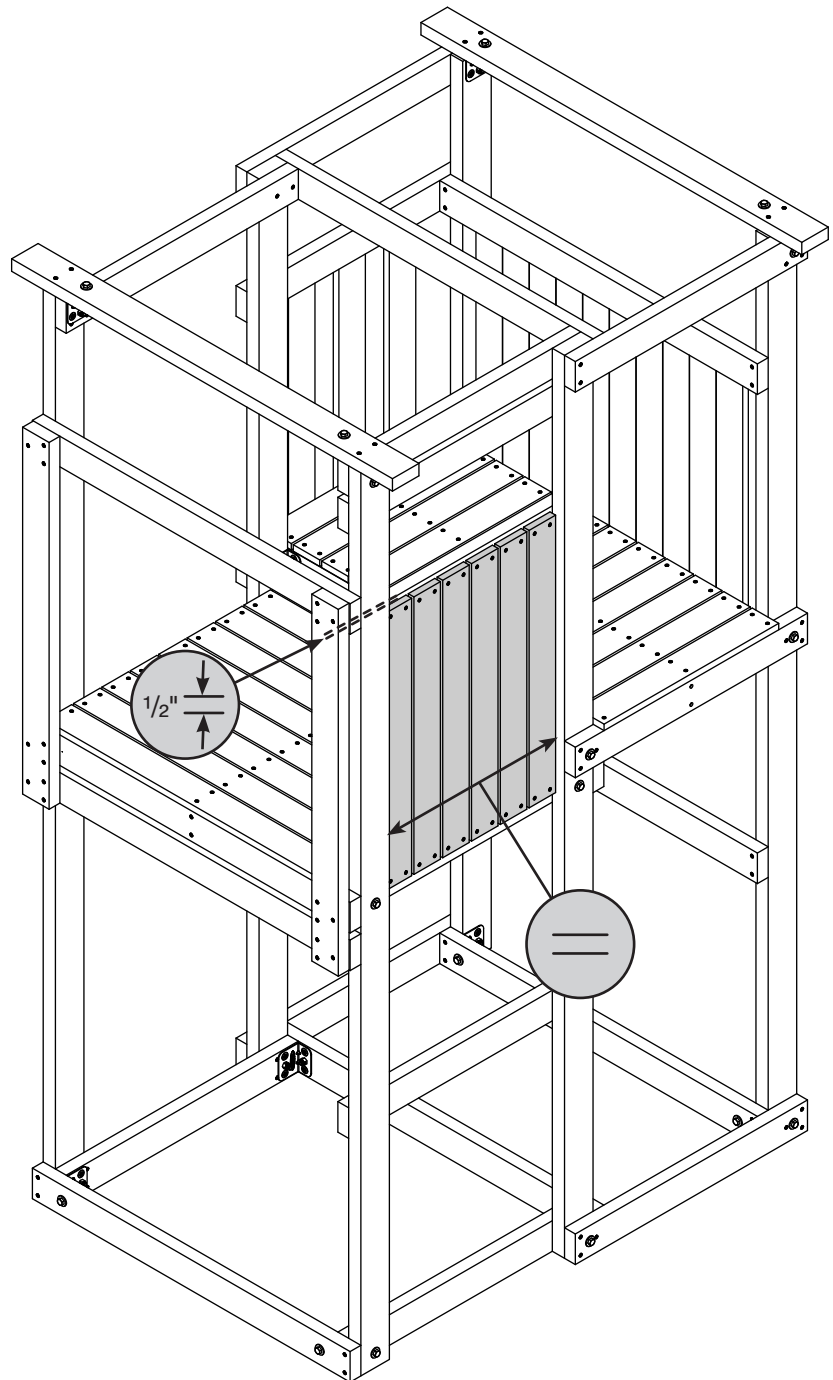
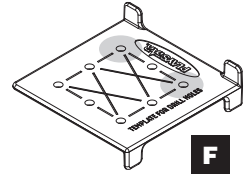
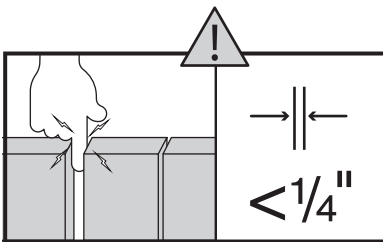
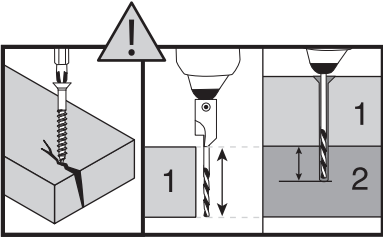
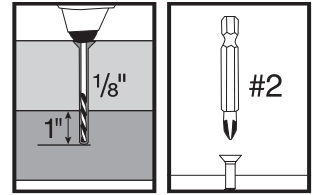

23

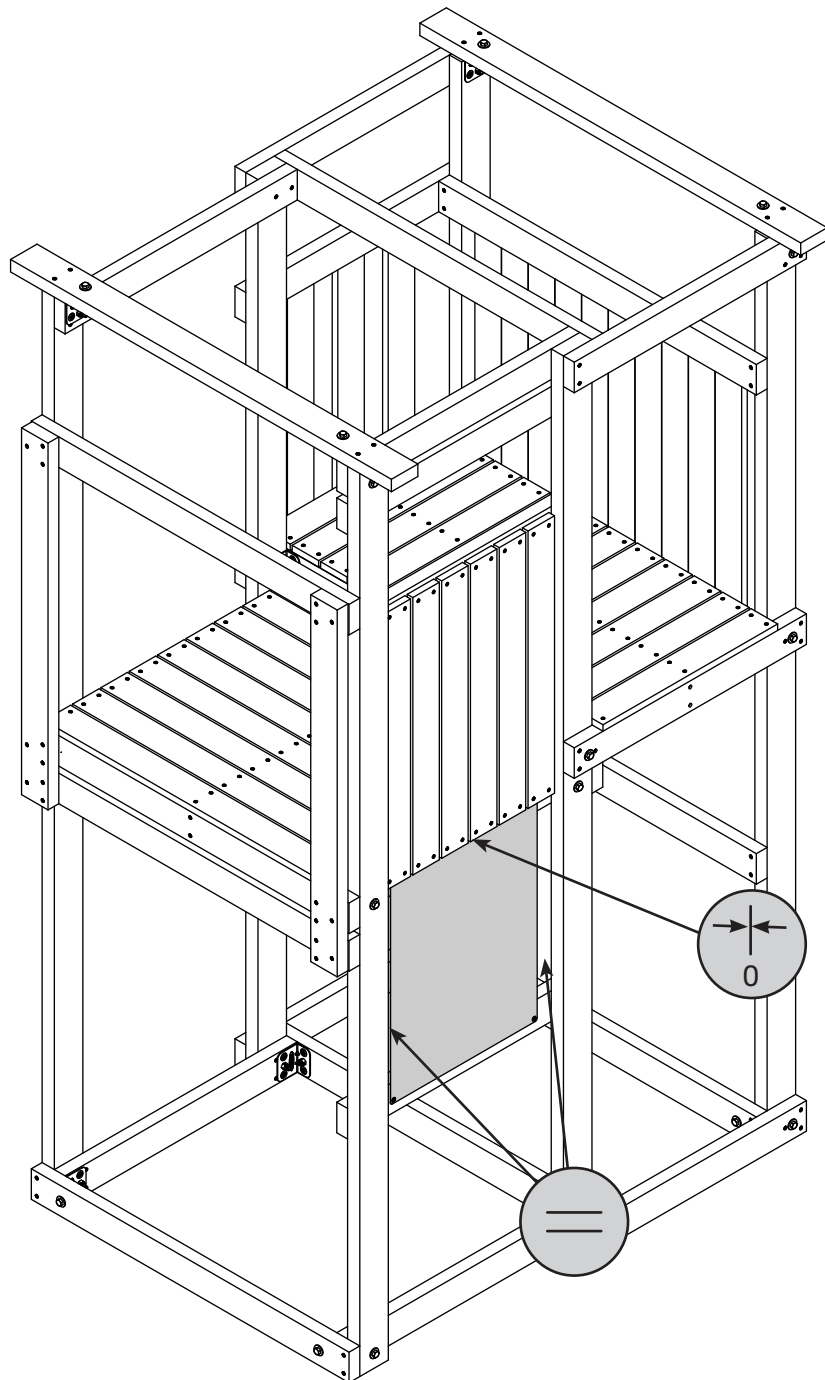
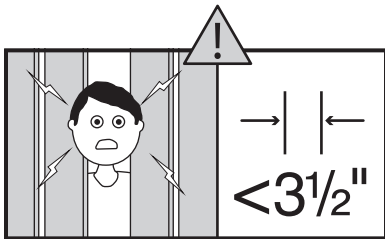
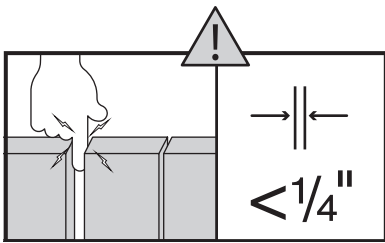
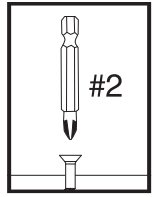
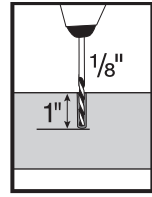
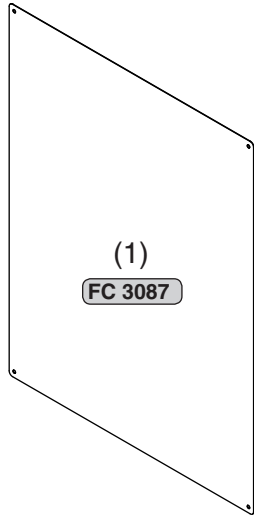
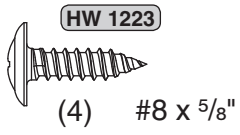

24

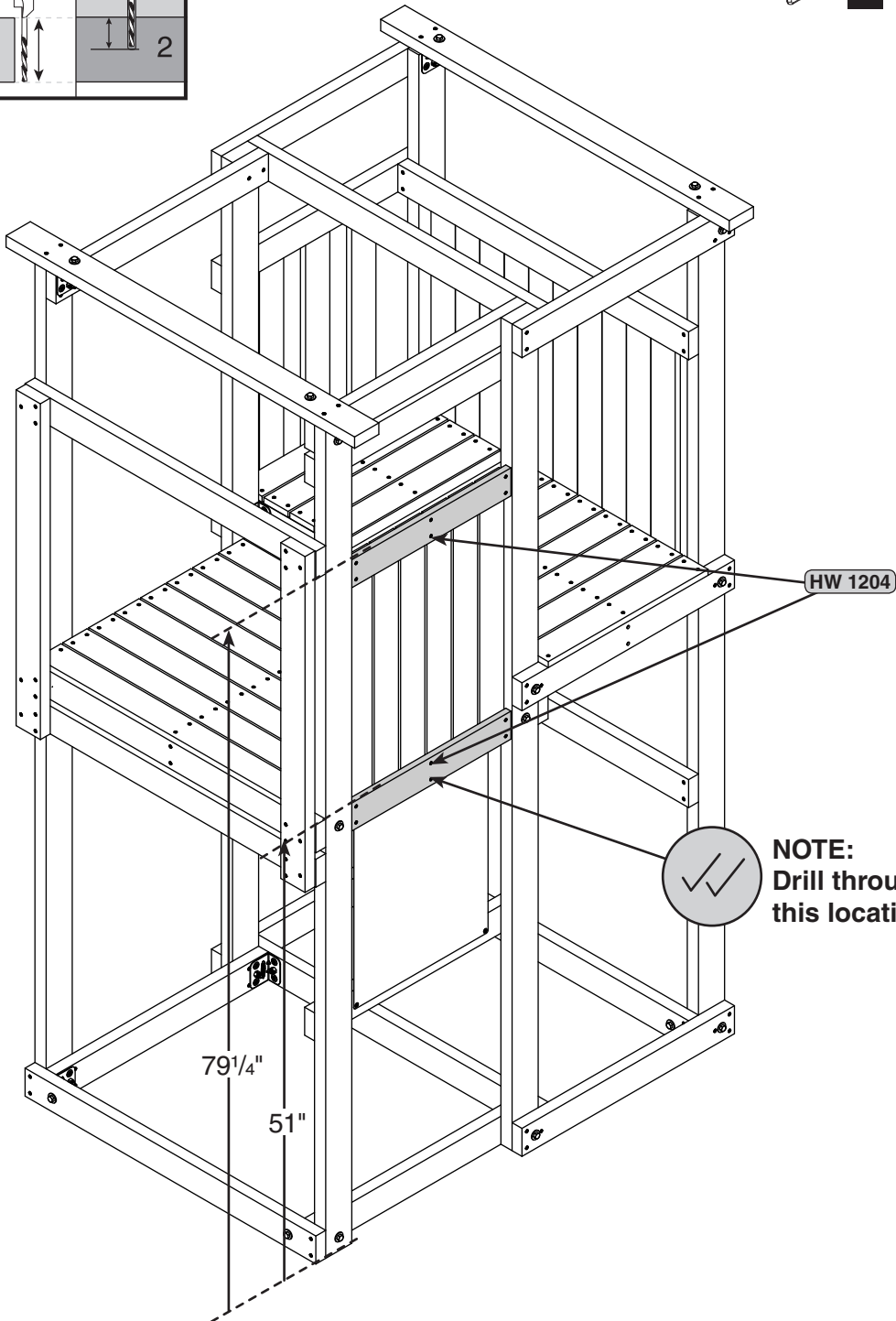
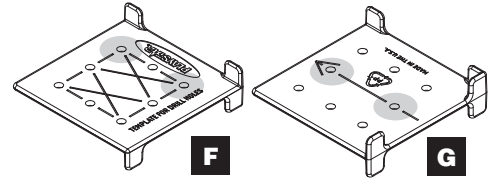
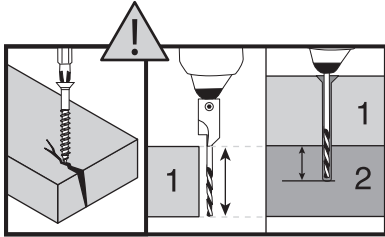
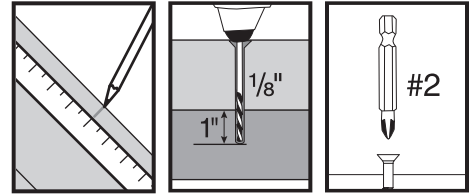
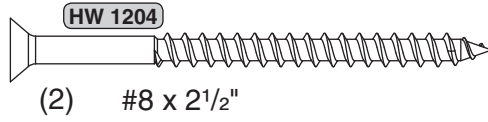
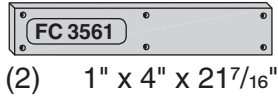
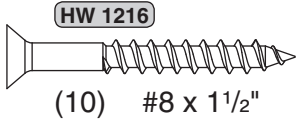

NOTE:
Drill through chalkboard in this location.



25

HW 1213
(8) #8 x 1 1/4"

FC 3563

(2) 1" x 4" x 12"

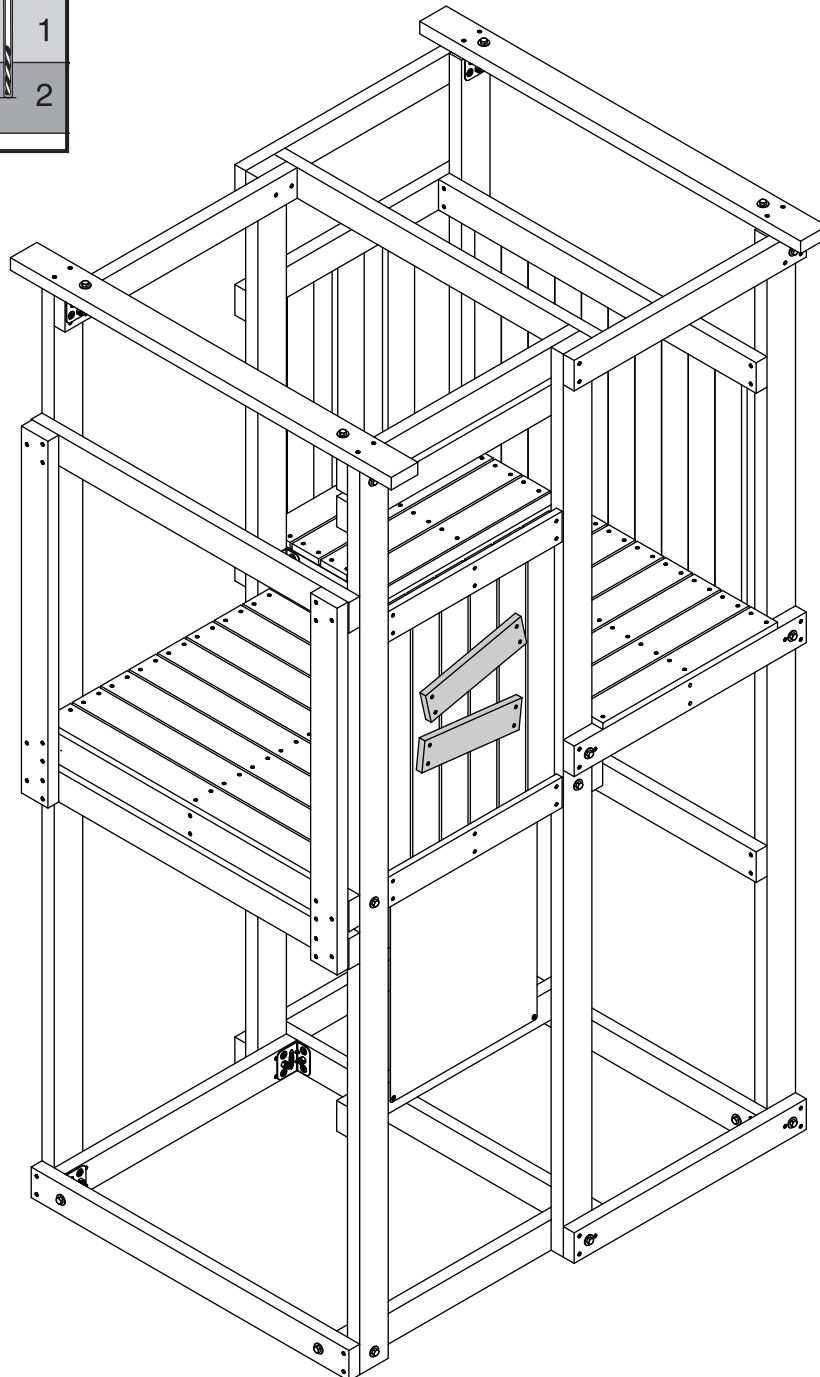
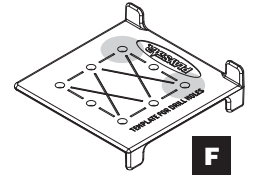
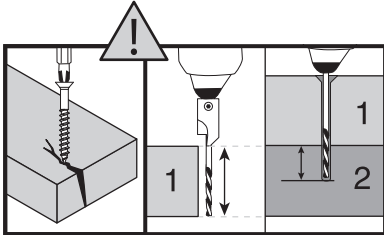
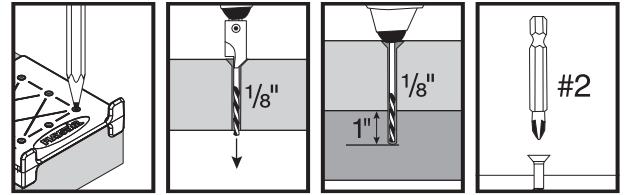

26

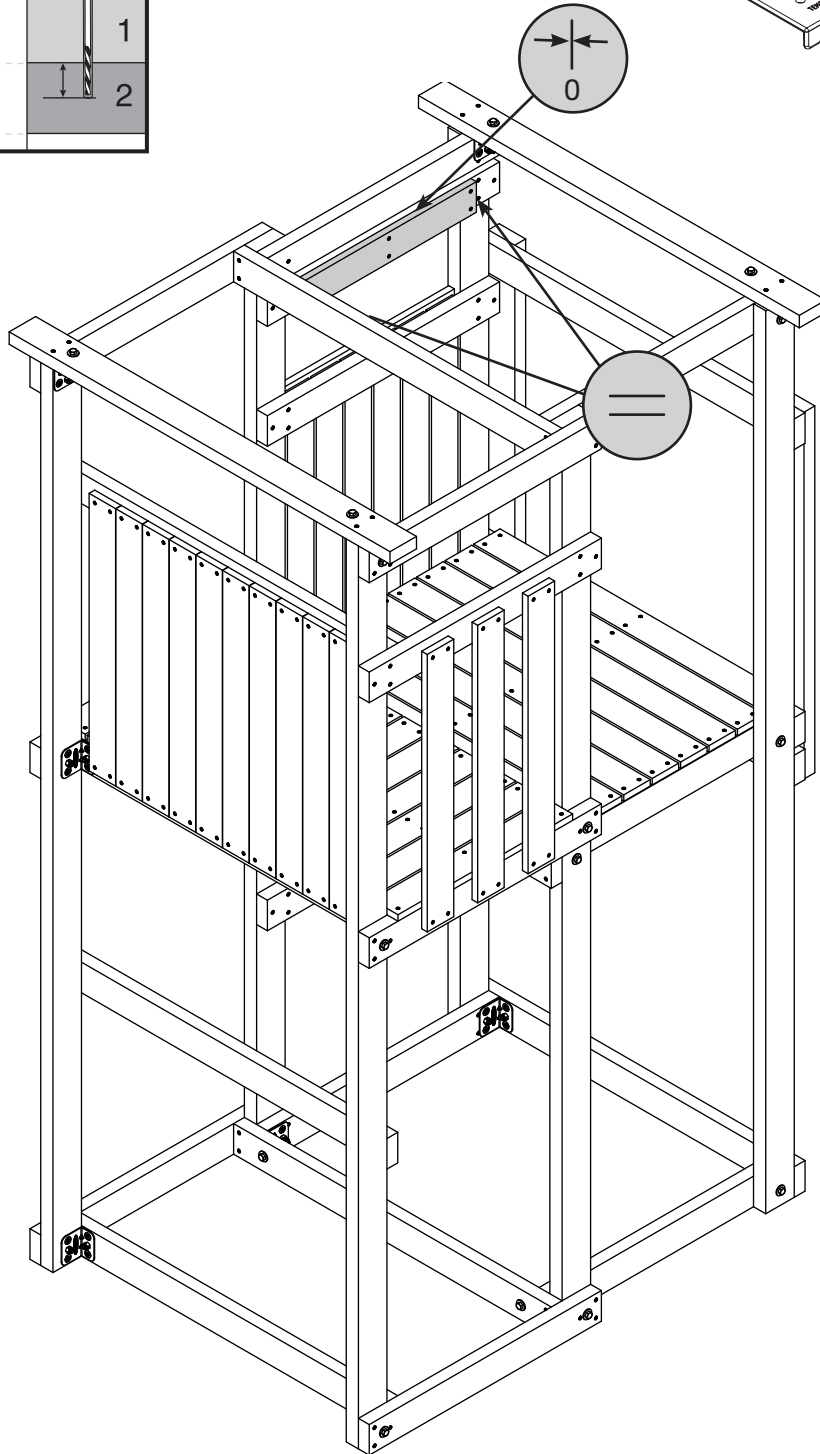
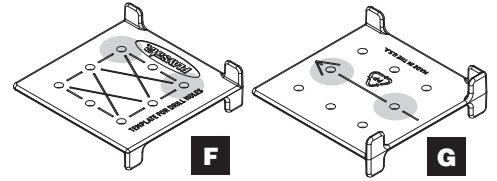
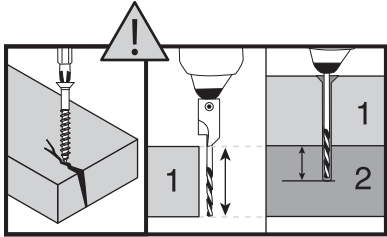
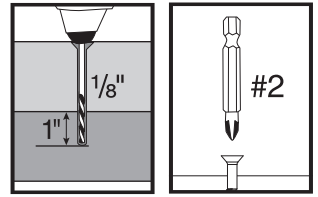
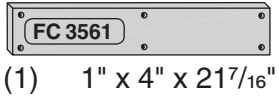
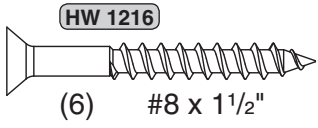

27

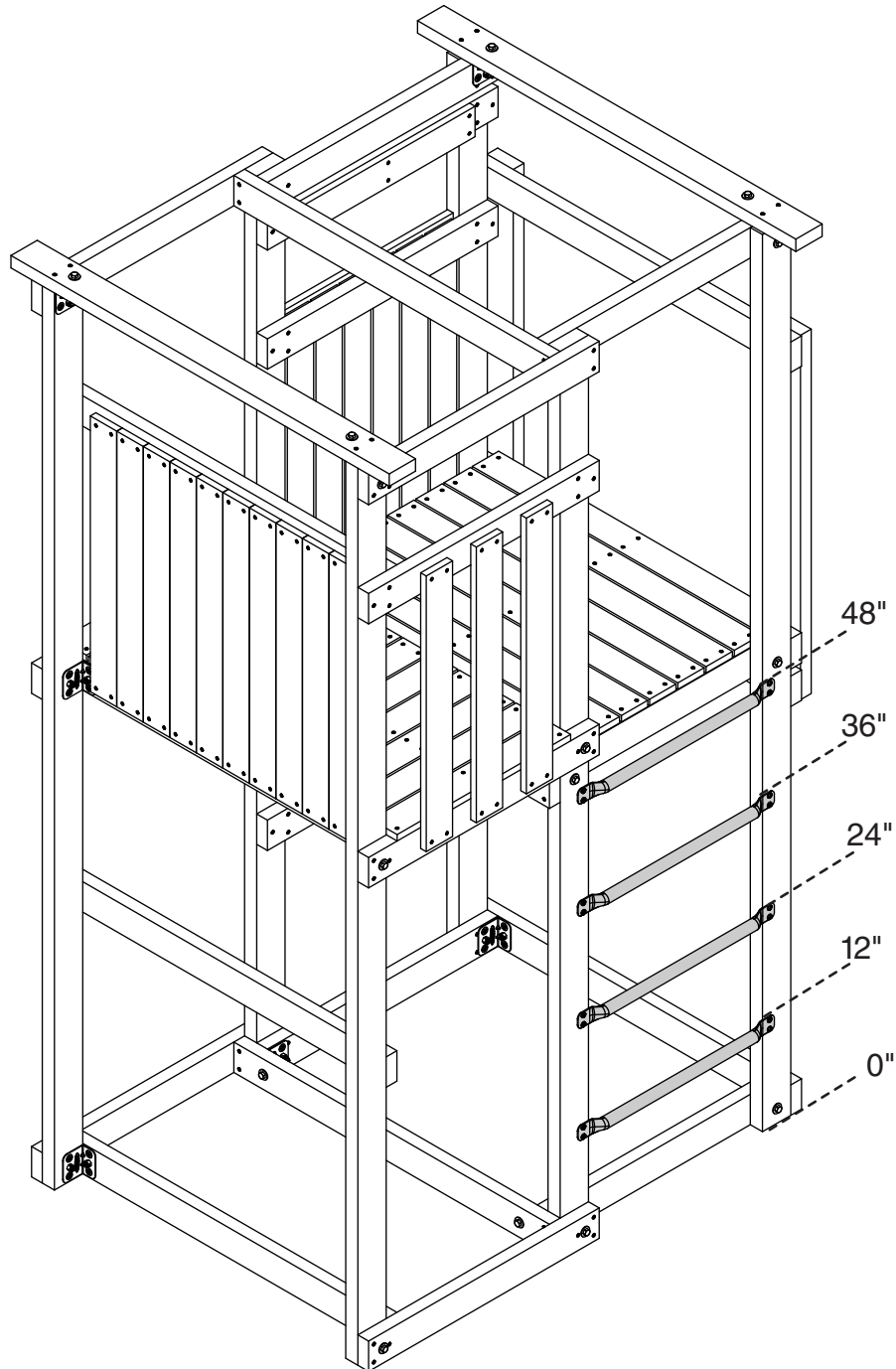
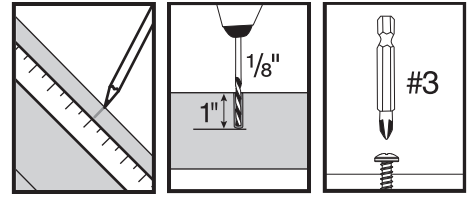
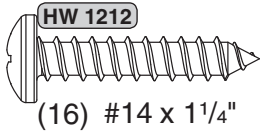

Roof

1

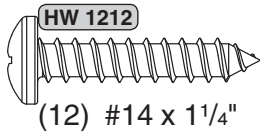

(2) 2" x 4" x 39"



(2) 2" x 4" x 42 1/4"

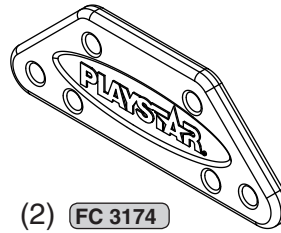

(2) FC 3174

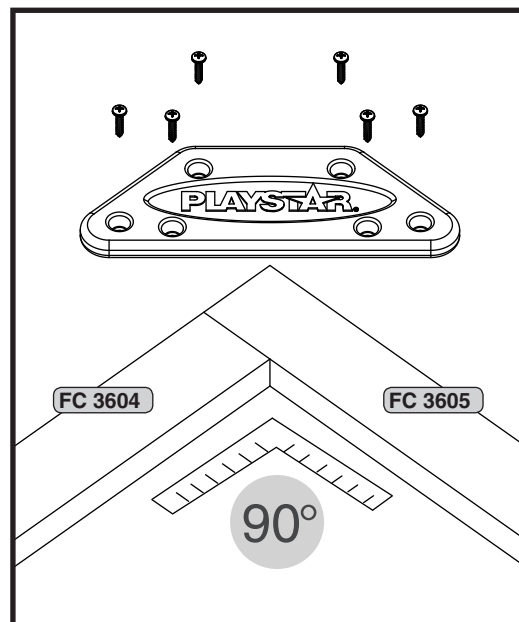
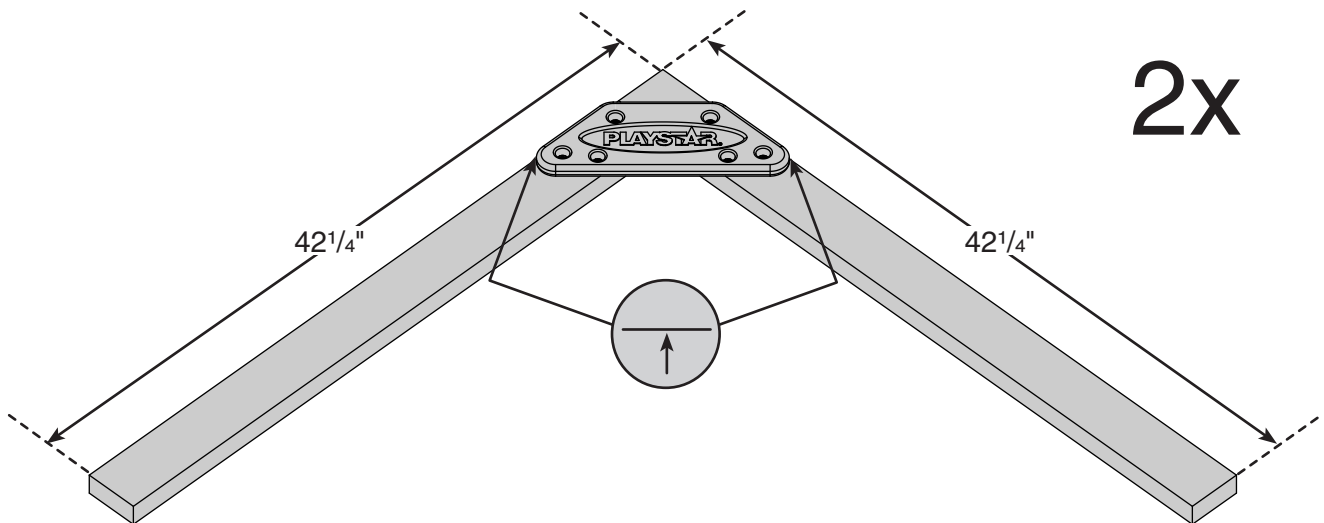
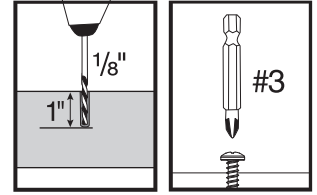

2

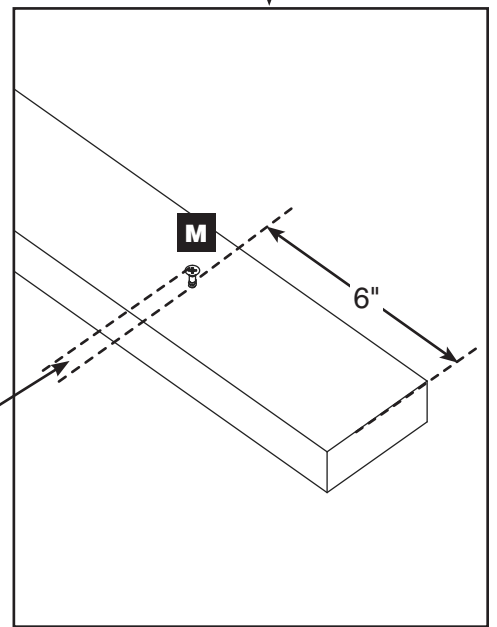
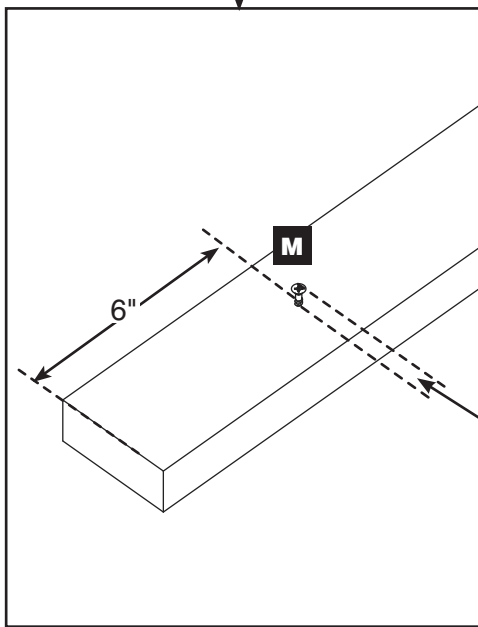
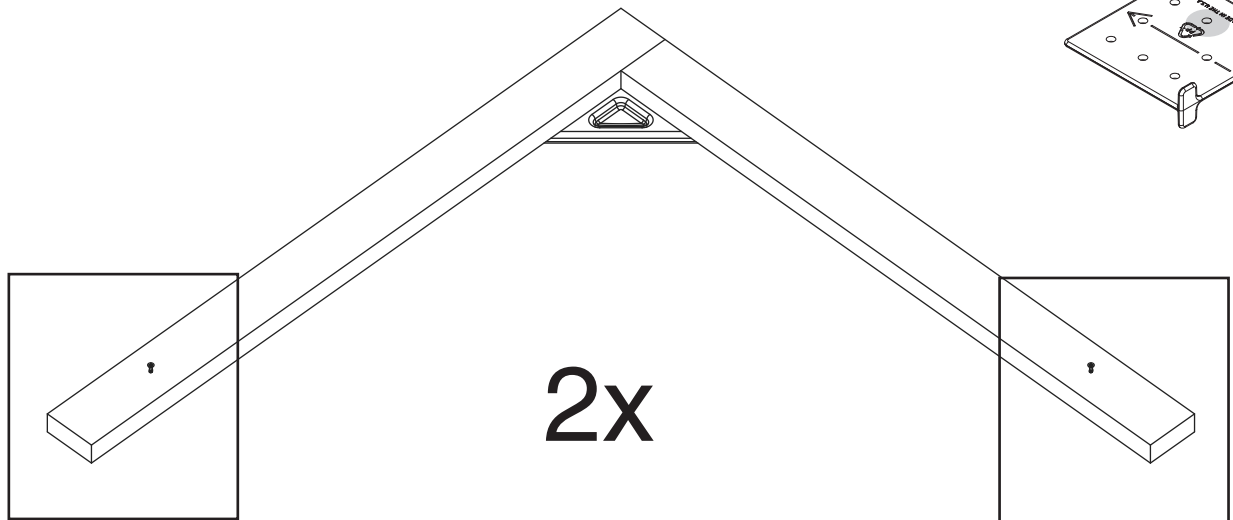
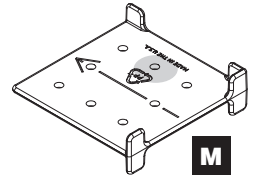
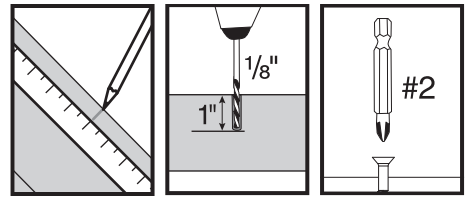
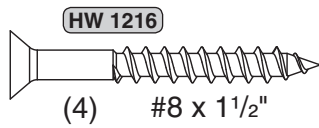

NOTE:
Leave screw
sticking out
1/2" for use in
attaching roof
at a later step.

3

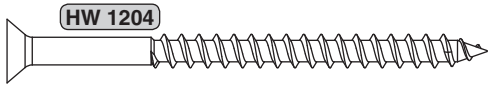

(3) 2" x 4" x 46 3/4"

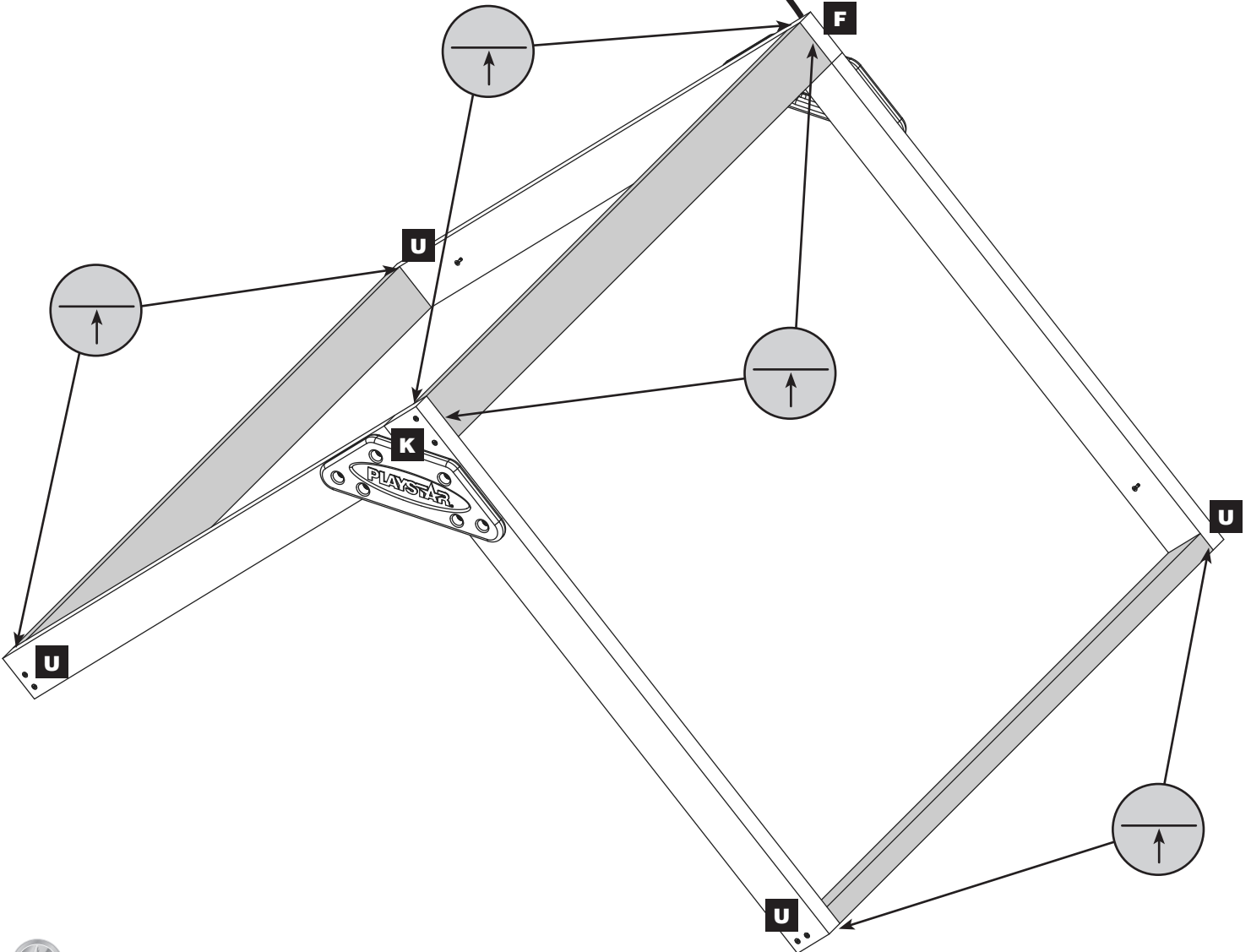
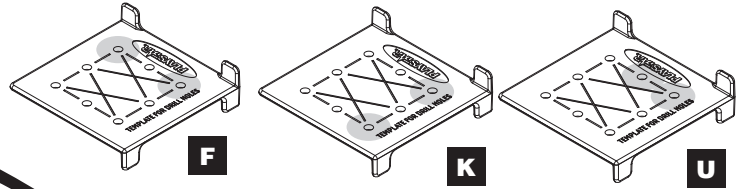
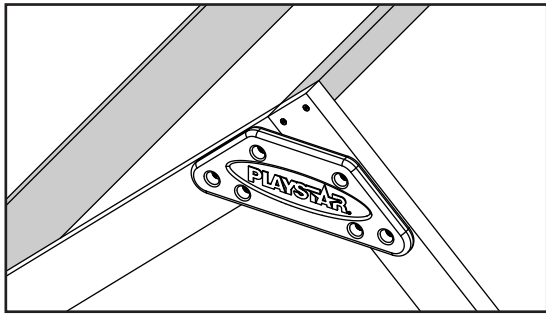
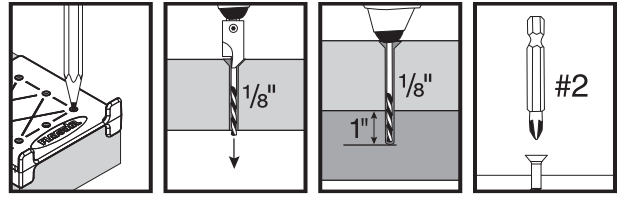

4

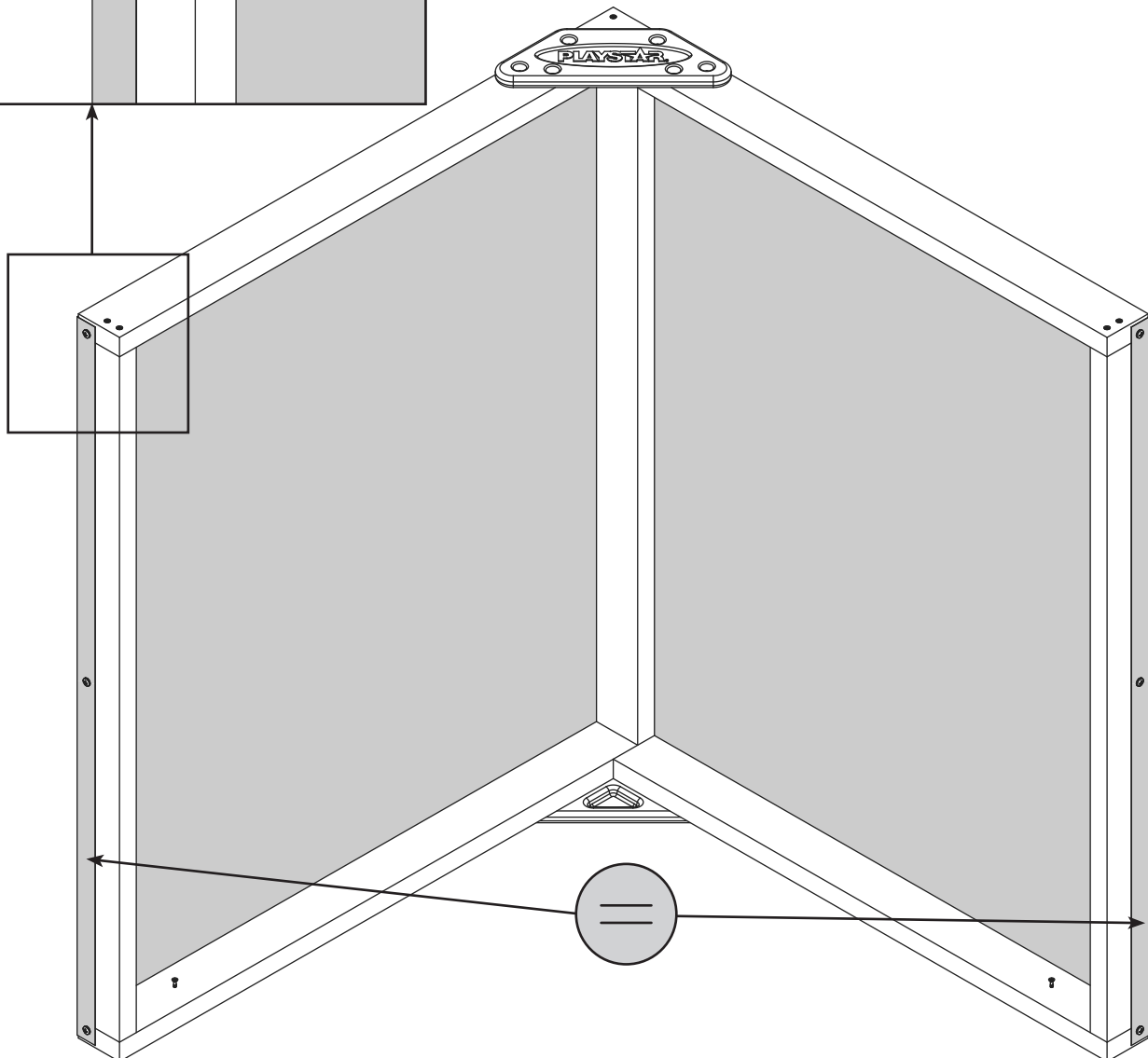
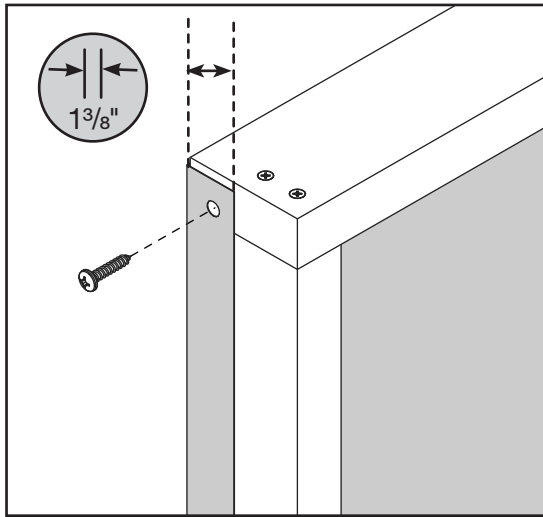
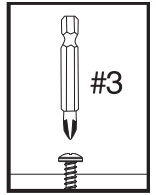
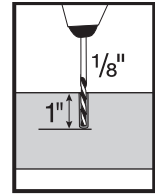
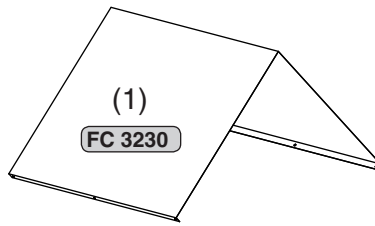
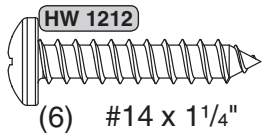

5

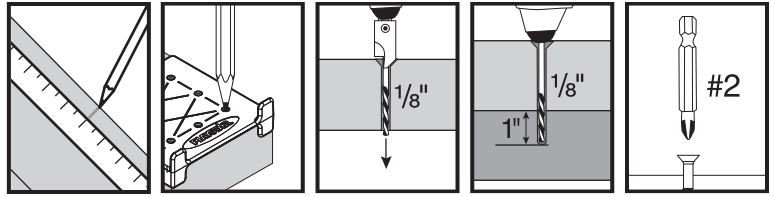
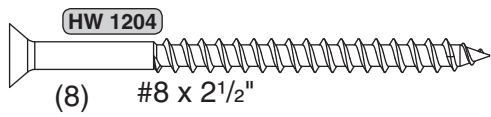

NOTE:
Rest screw on board.

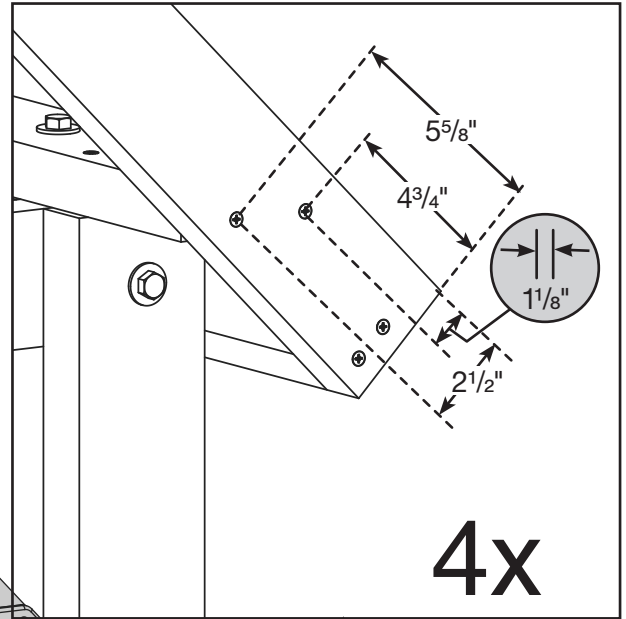
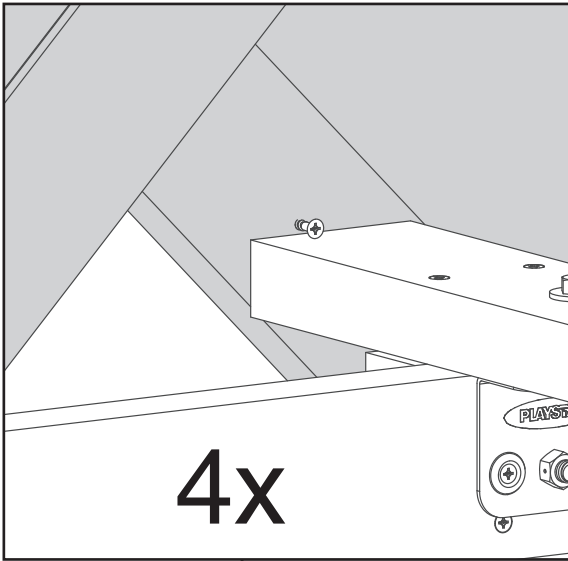

NOTE:
Be sure roof is level with equal overhang on all four corners.

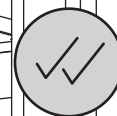

NOTE: Bronze tower pictured.



Picnic Table

1

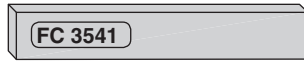
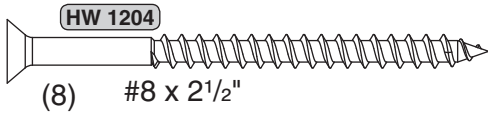

(2) 2" x 4" x 24 1/4"

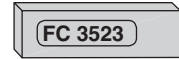

(2) 2" x 4" x 13 1/8"

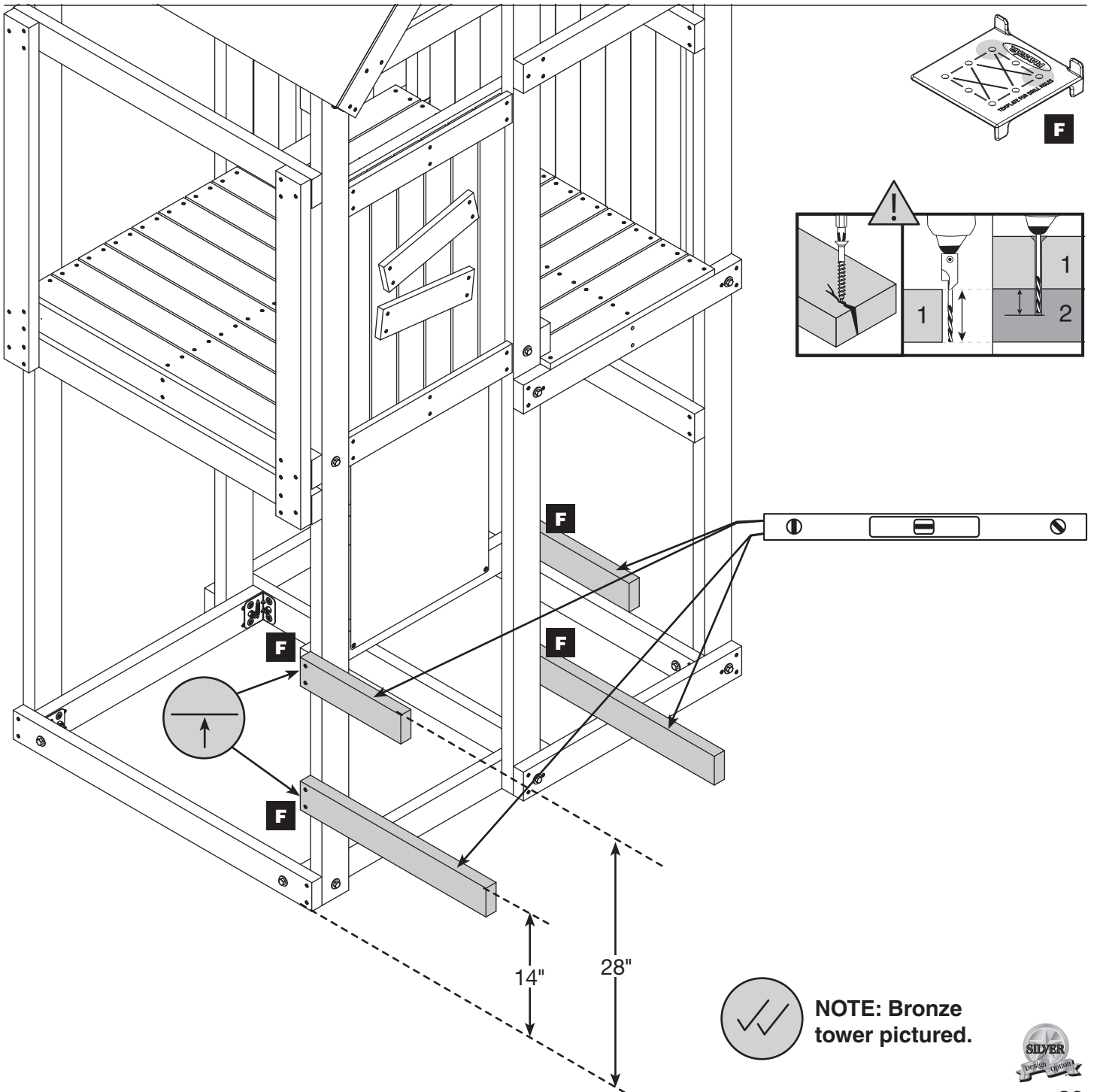
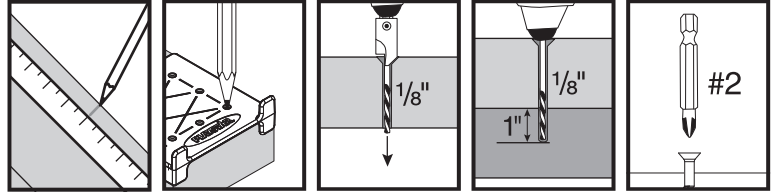

2

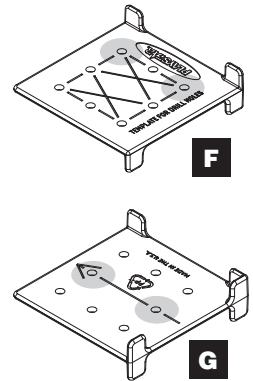
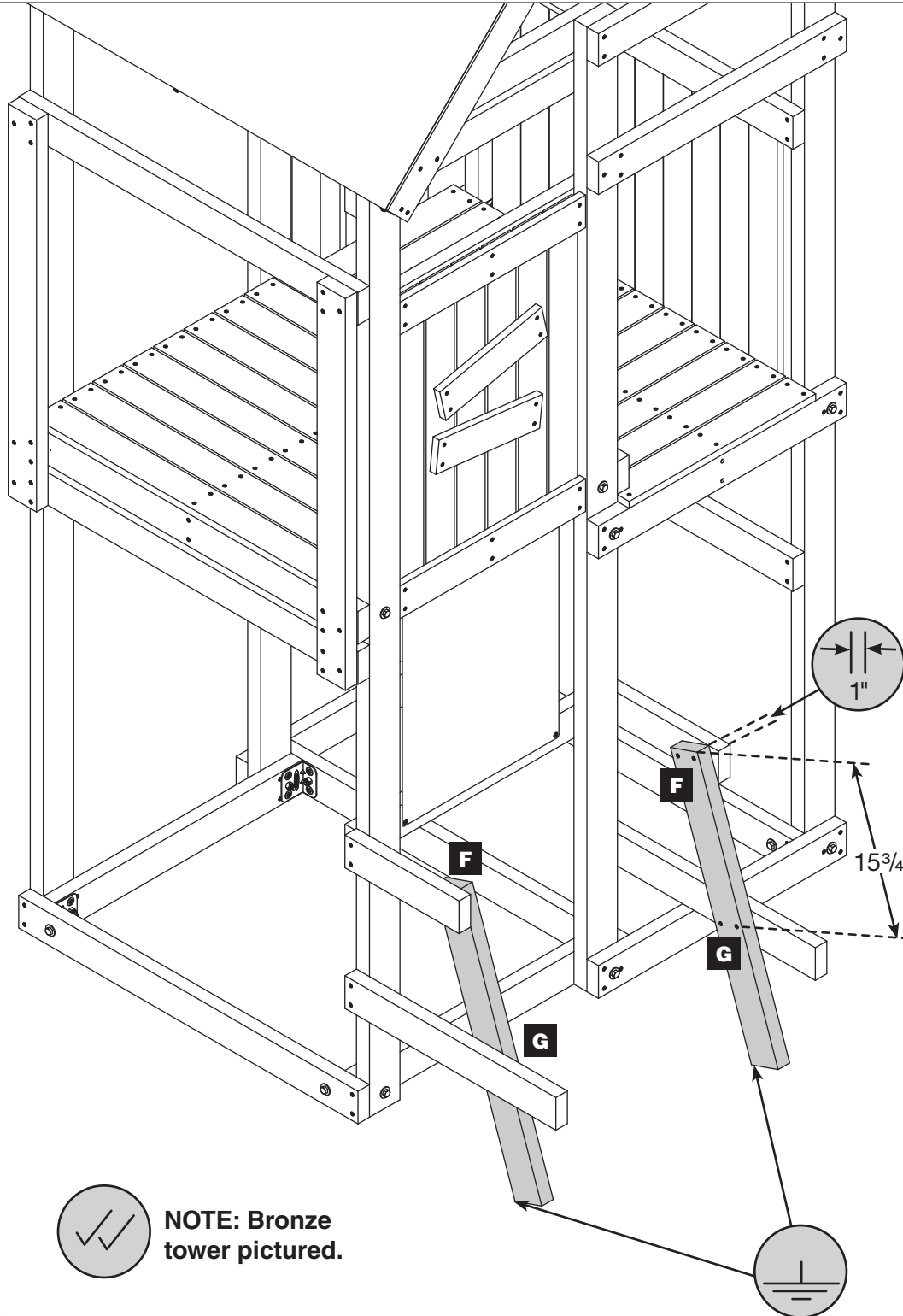
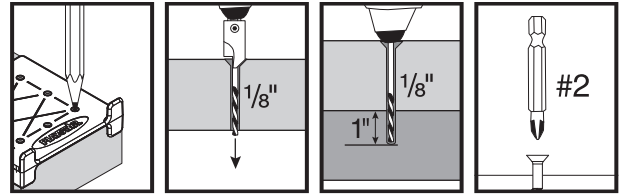
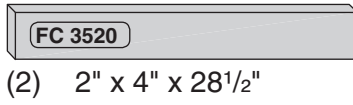
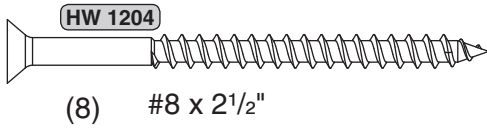

3

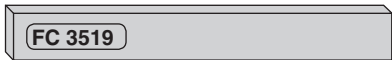
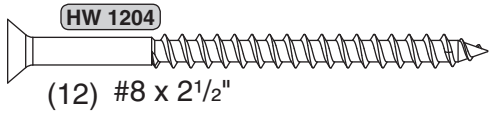

(3) 2" x 4" x 31 1/2"

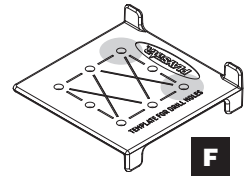
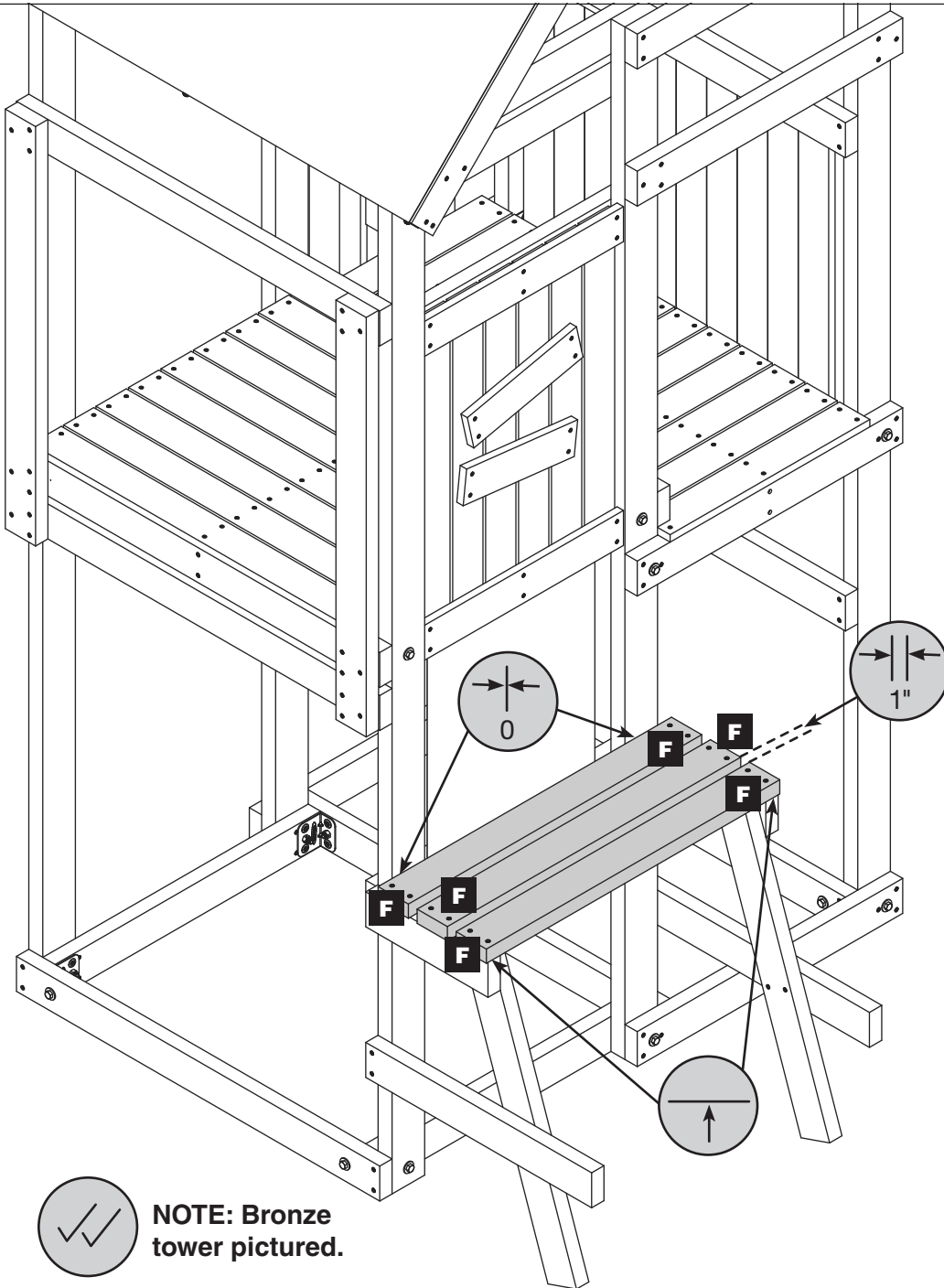
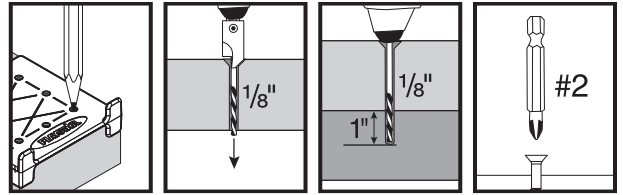

NOTE: Bronze tower pictured.



4

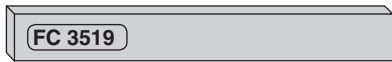
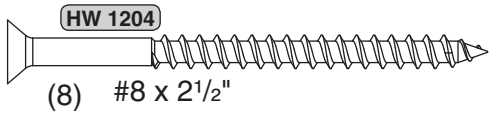

(2) 2" x 4" x 31 1/2"

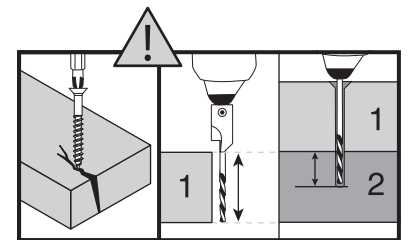
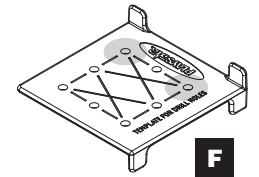
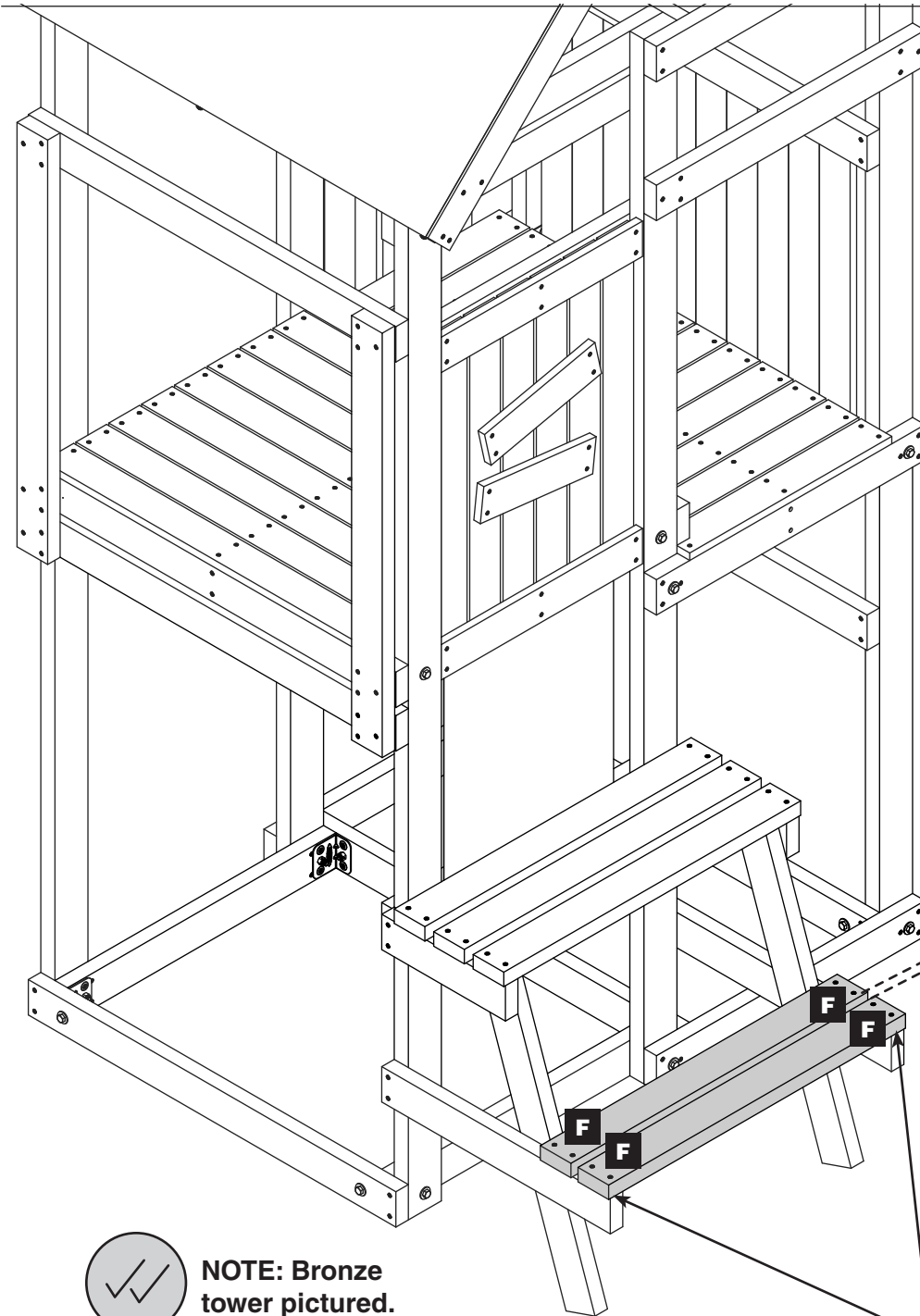
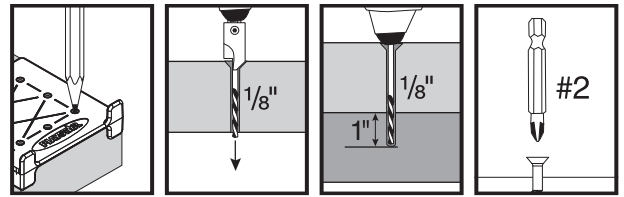

NOTE: Bronze tower pictured.



Swing Beam

1

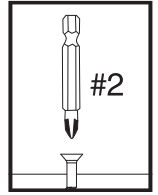
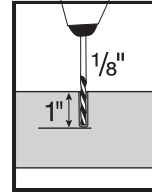
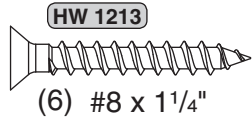
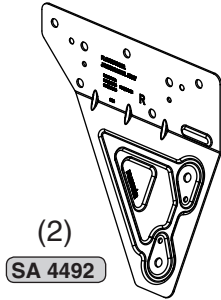
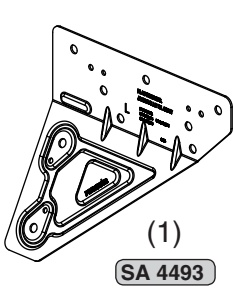

(3) 4" x 4" x 8'

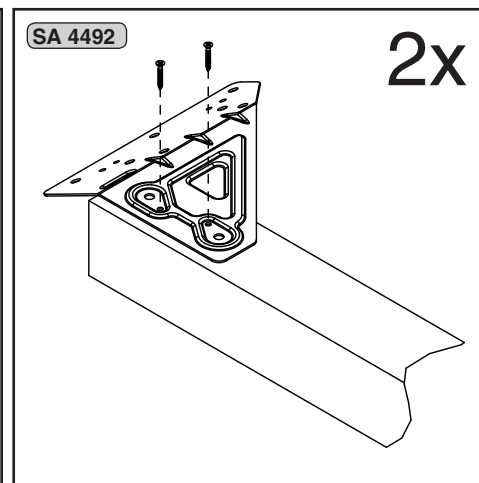
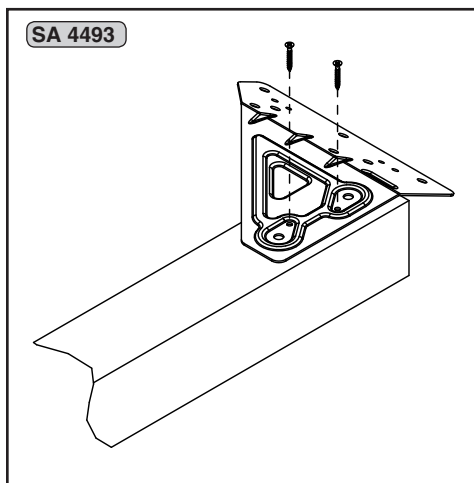
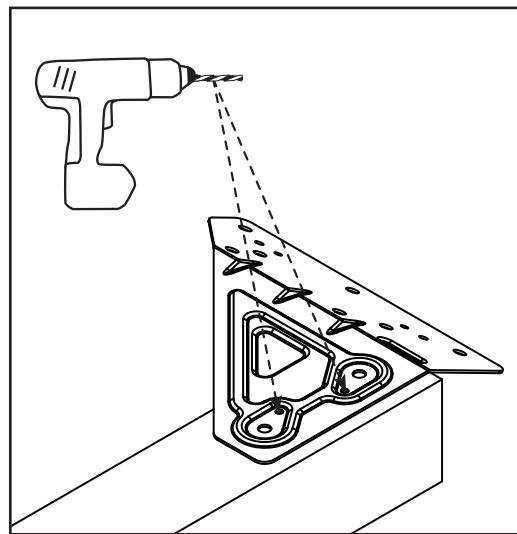
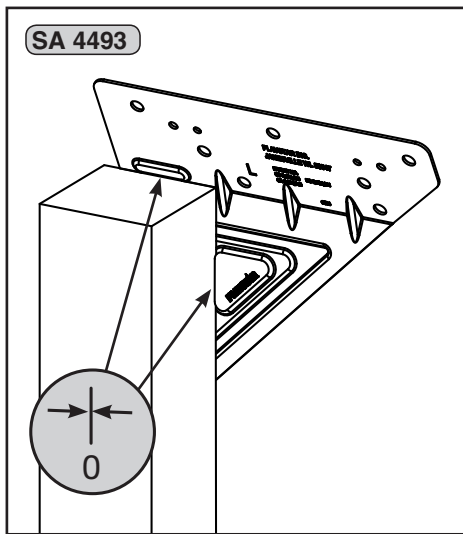

2

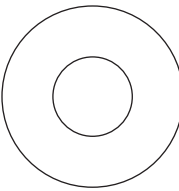

HW 1301
(6) 3/8"

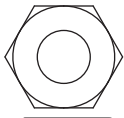

HW 1411
(6) 3/8"

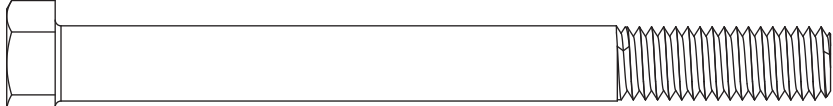
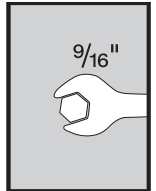
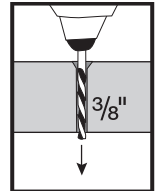

(6) HW 1514 3/8" x 4"

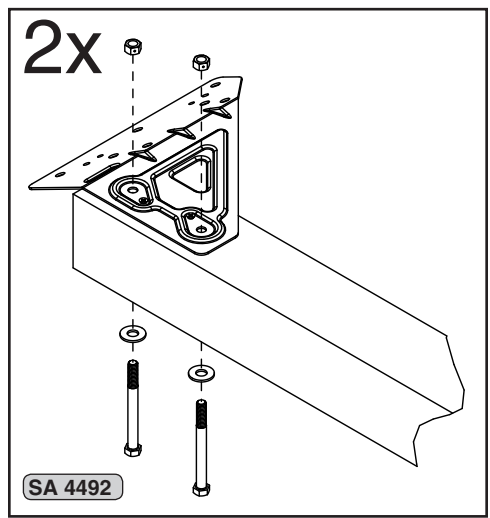
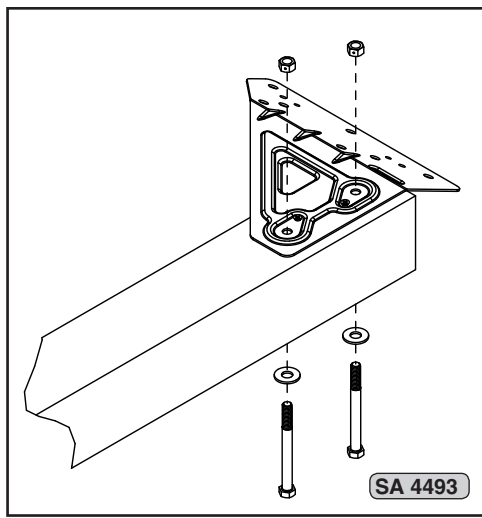
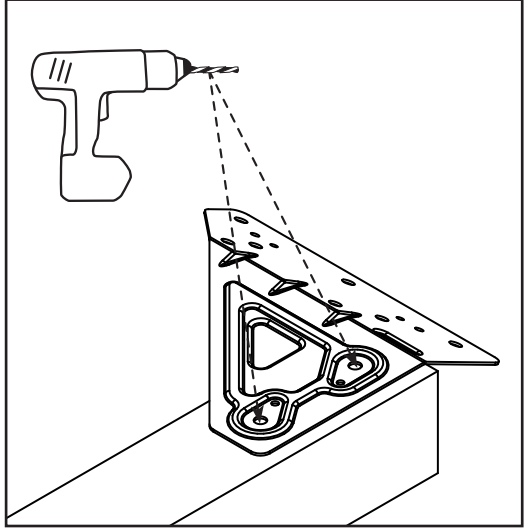
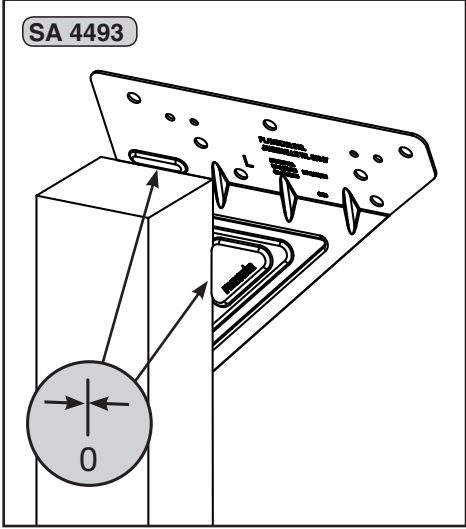

3

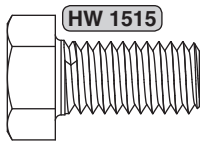

(4) 3/8" X 3/4"

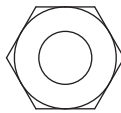

HW 1411

(4) 3/8"

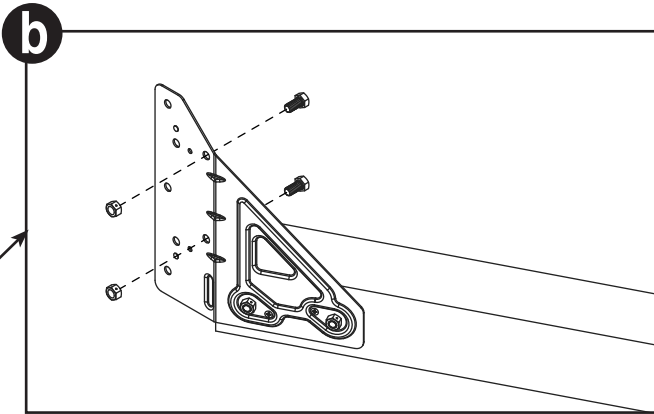
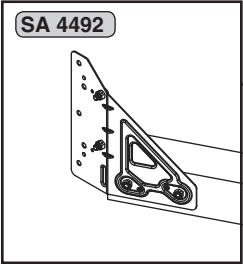
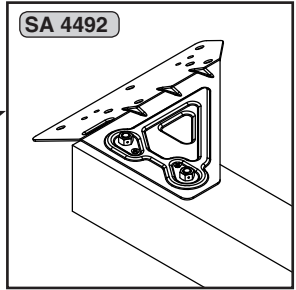
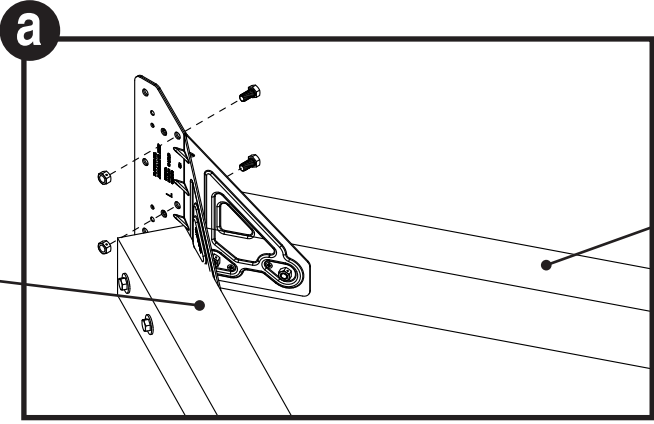
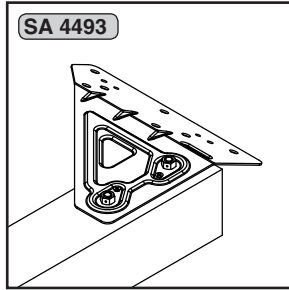
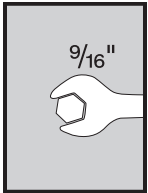

4



(1) 2" x 4" x 46³/₄"

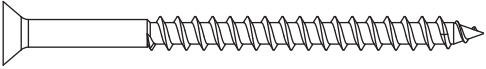

(6) HW 1204 #8 x 2¹/₂"

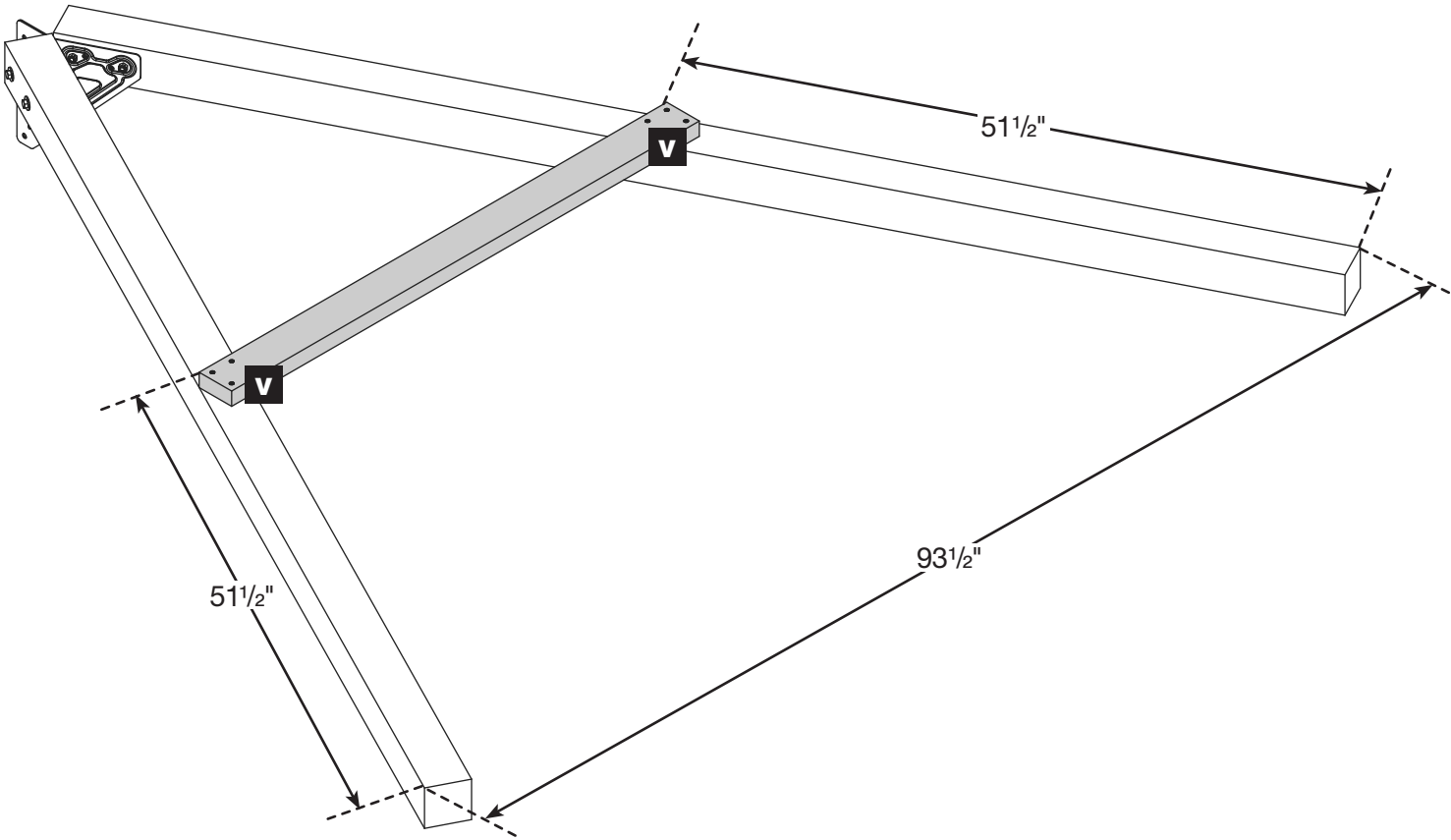
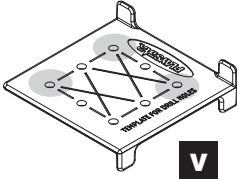
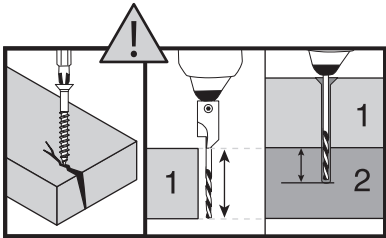
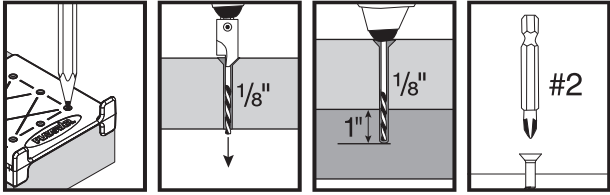

5

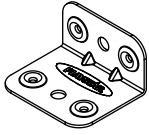

(2) SA 4496

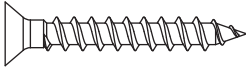

(8) HW 1213 #8 x 1 1/4"

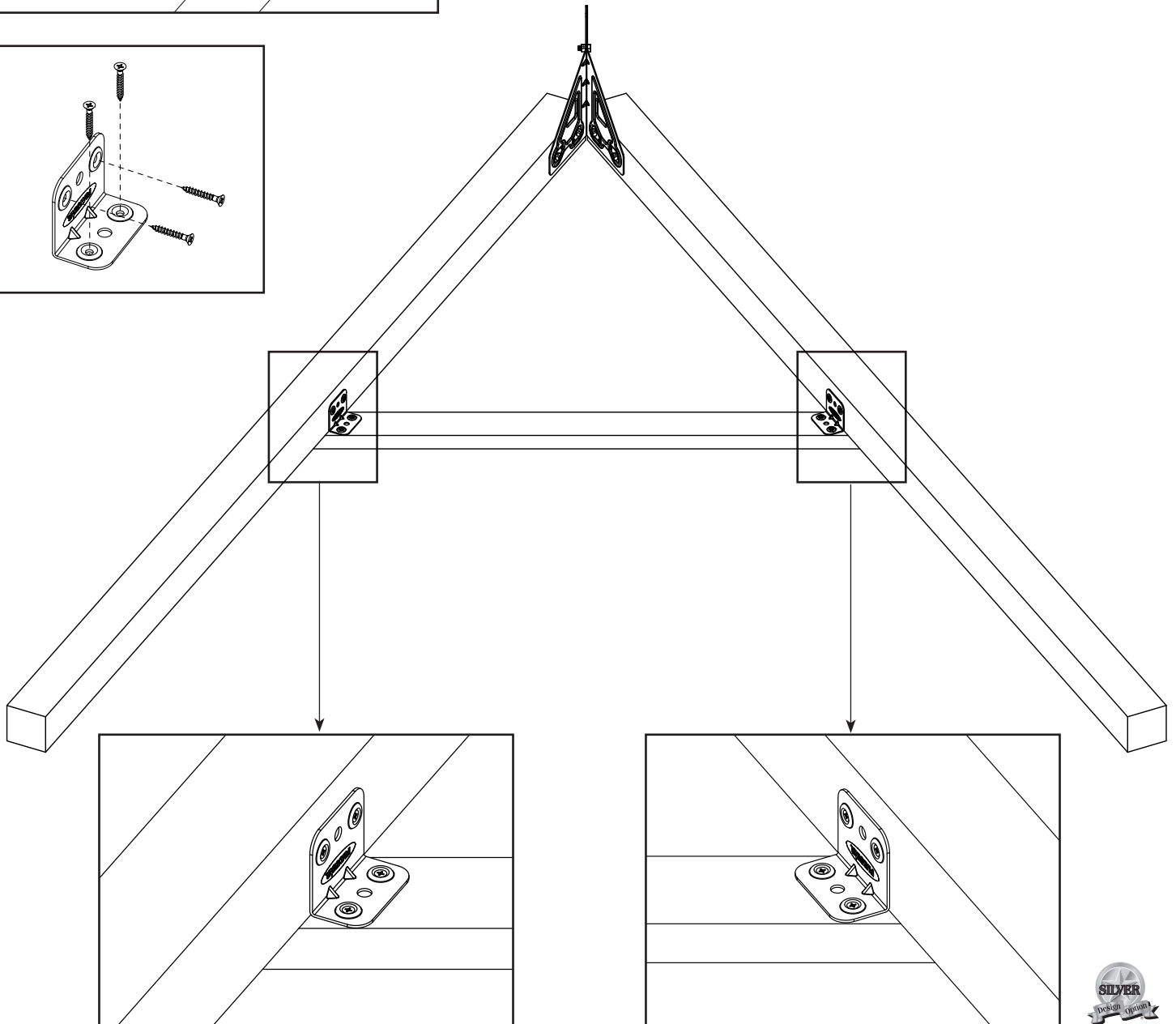
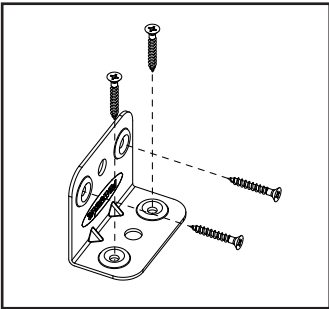
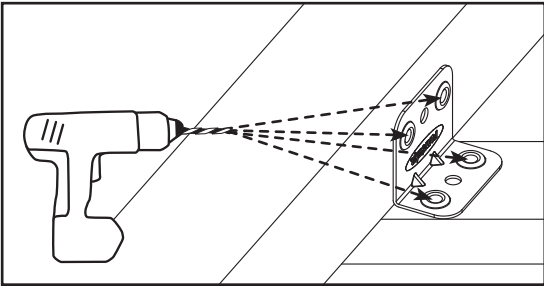
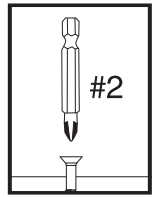
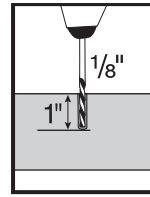

6

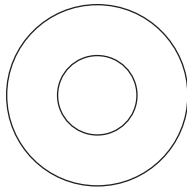
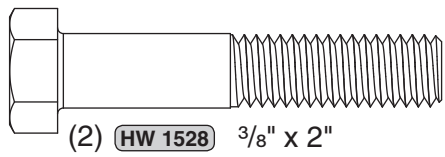

HW 1301
(4) 3/8"

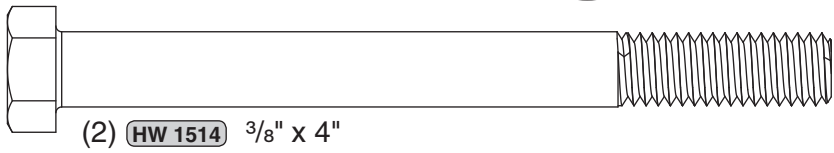
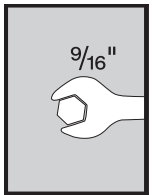
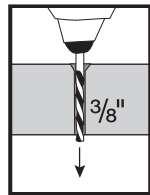

HW 1411
(4) 3/8"

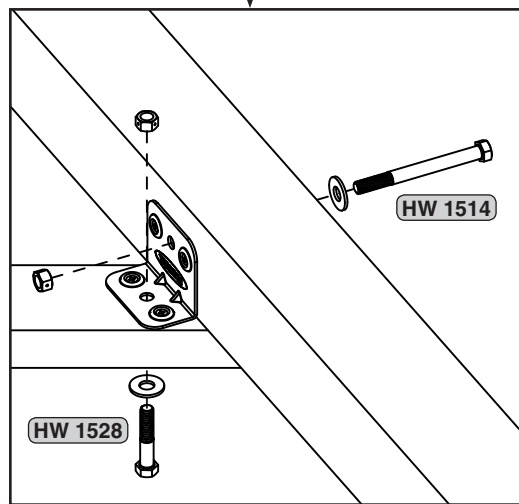
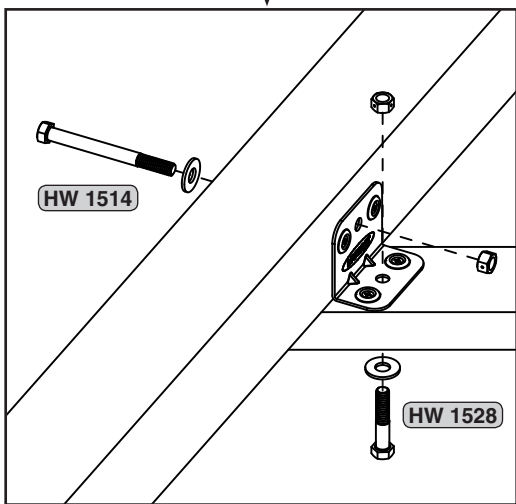
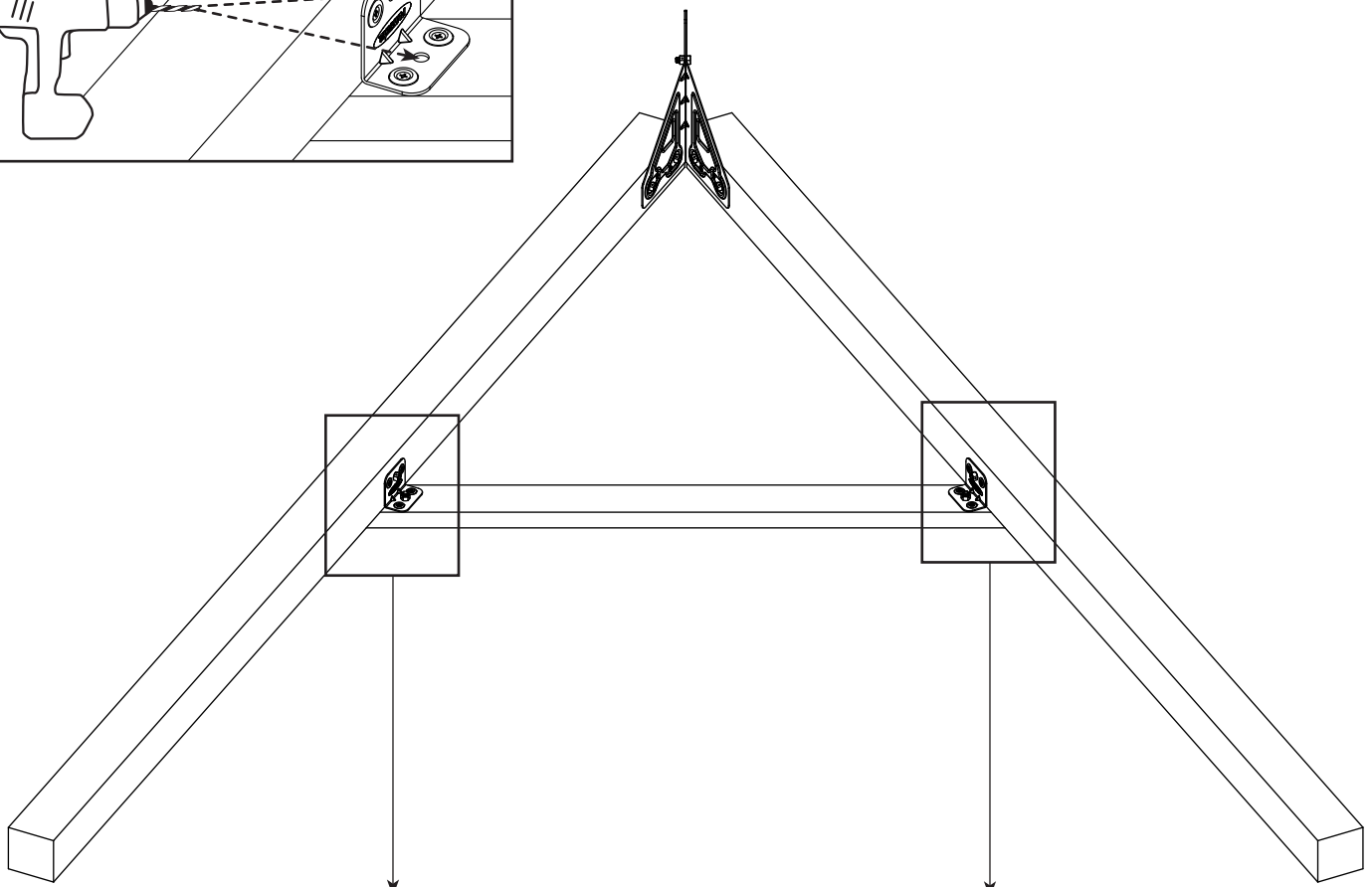
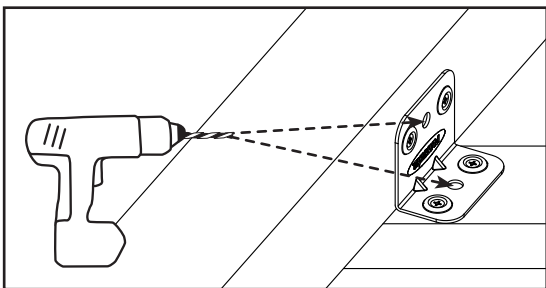

7

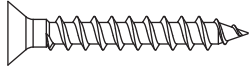

(4) HW 1213 #8 x 1 1/4"

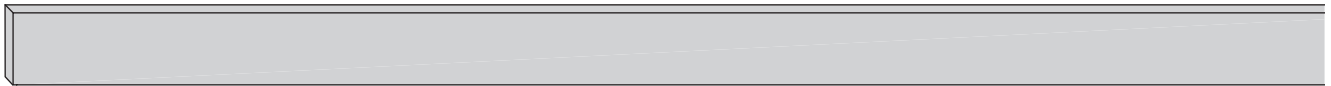
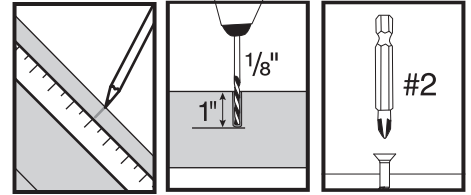

(1) 2" x 6" x 10'

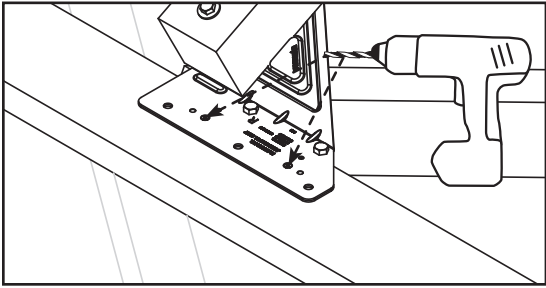

NOTE: If you do not have saw horses, rest beam on the ground.

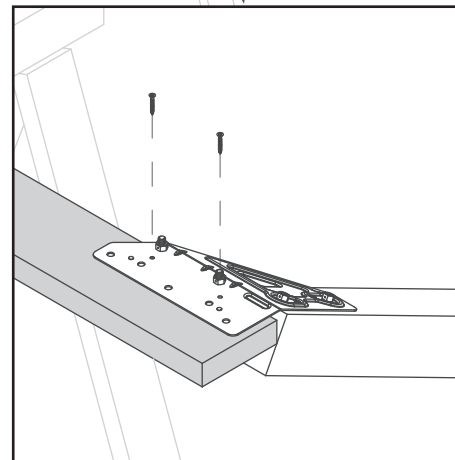
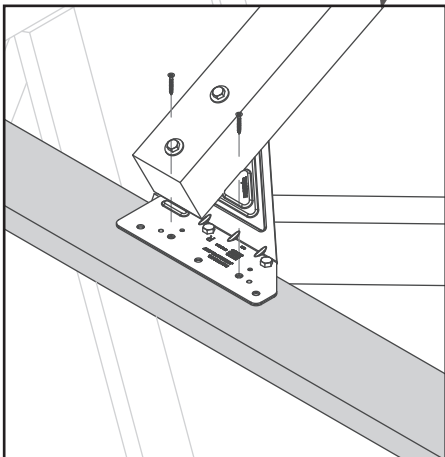
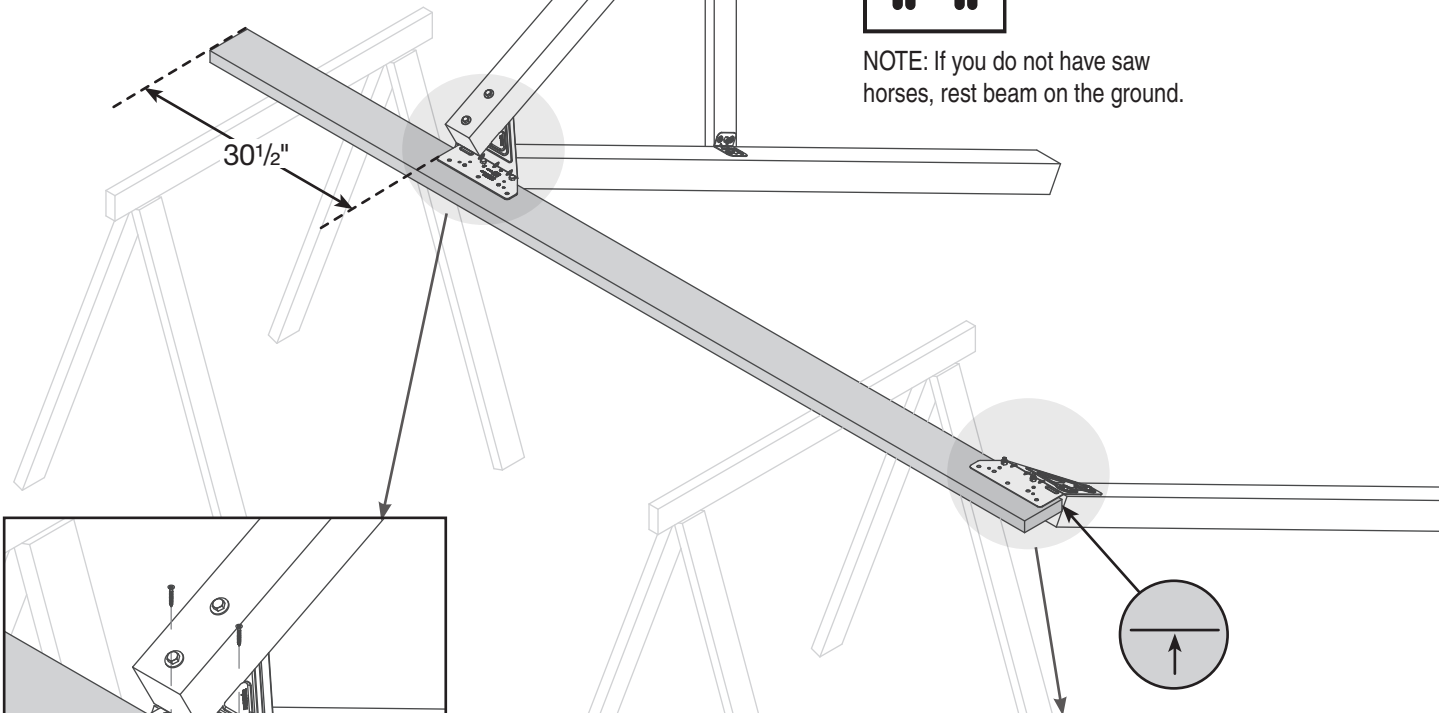

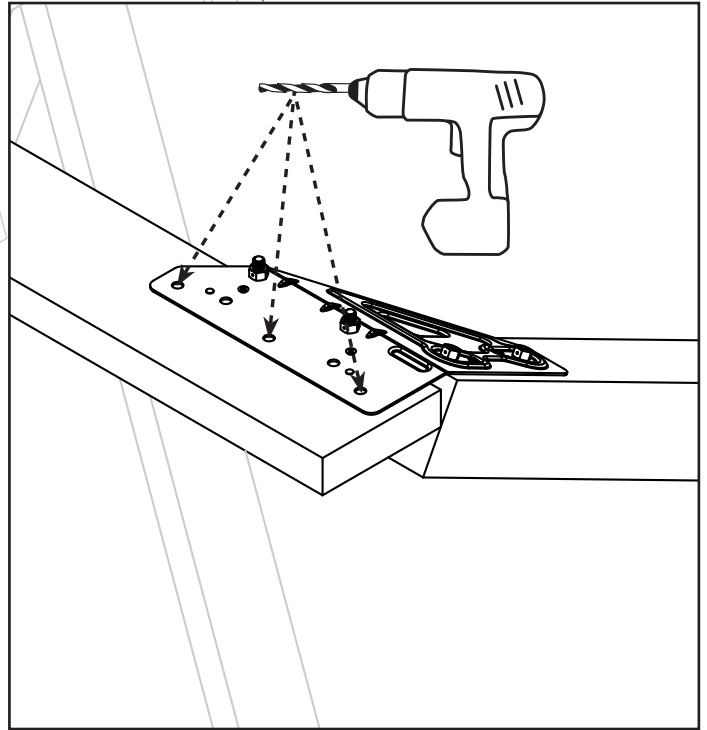
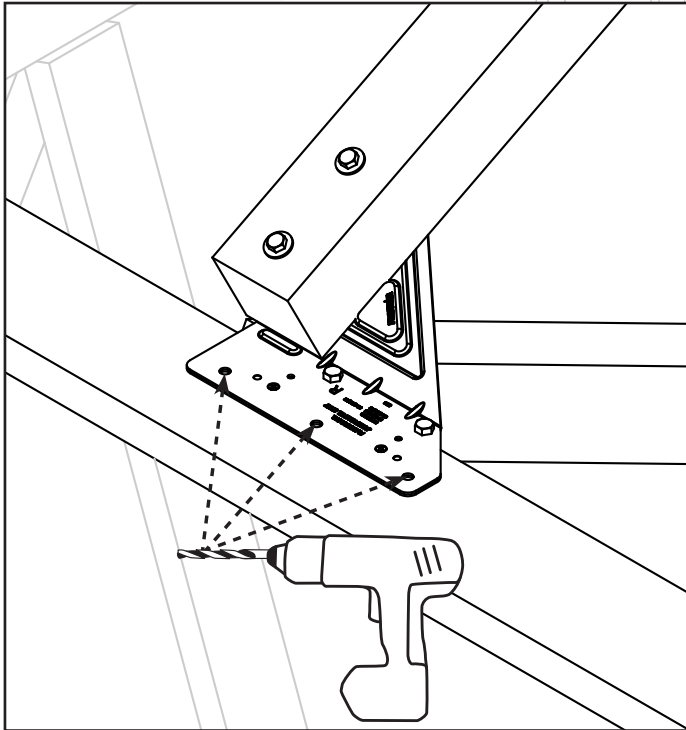
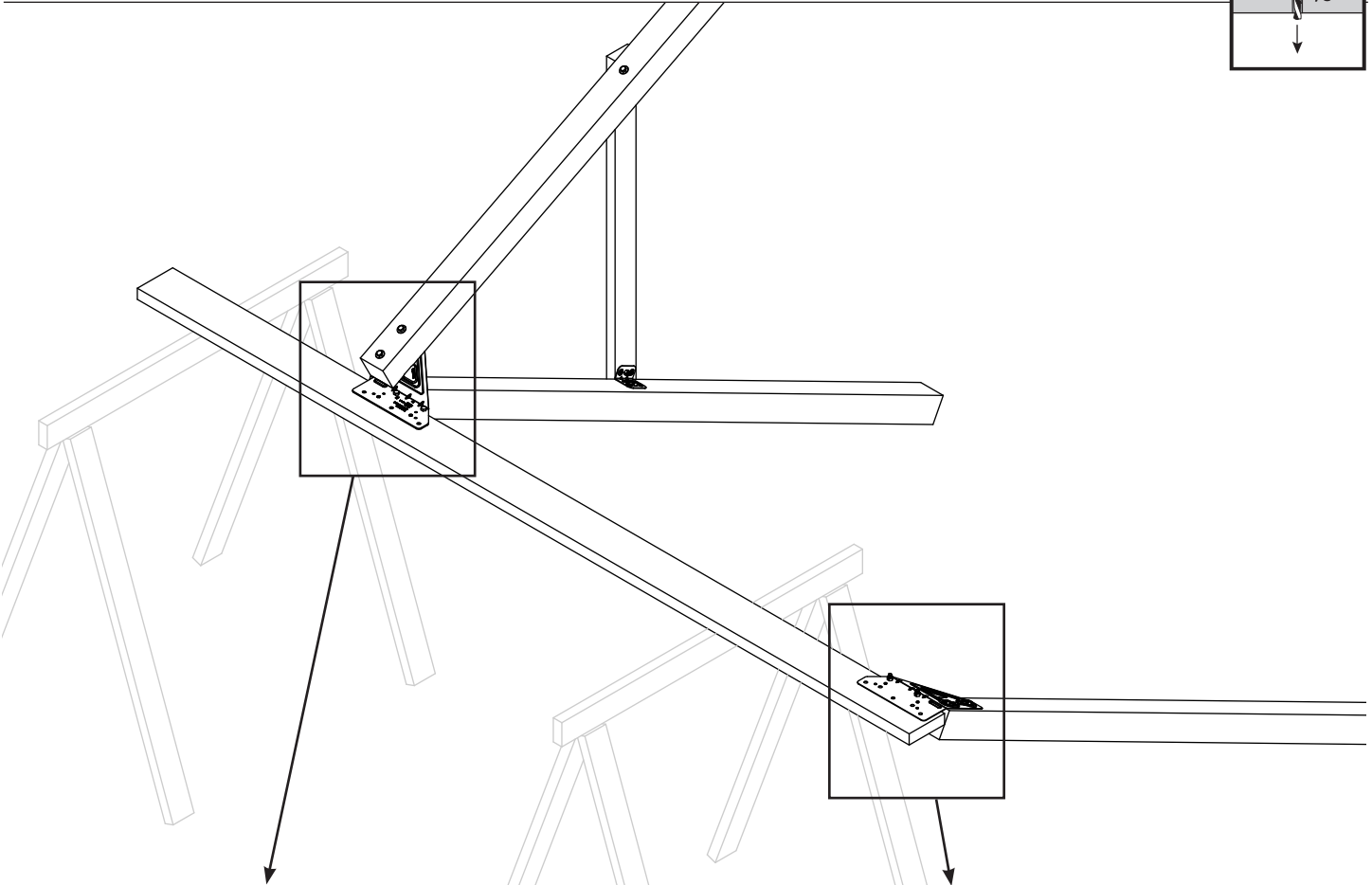
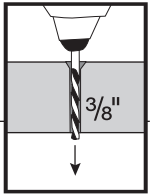

9

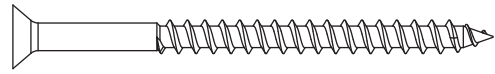

(10) HW 1204 #8 x 2 1/2"

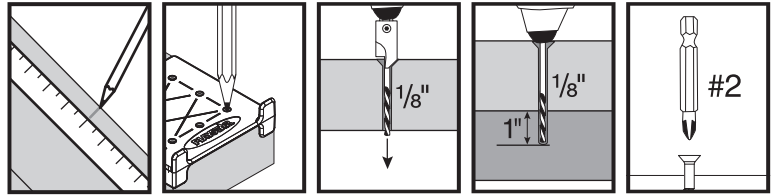

(1) 2" x 6" x 10'

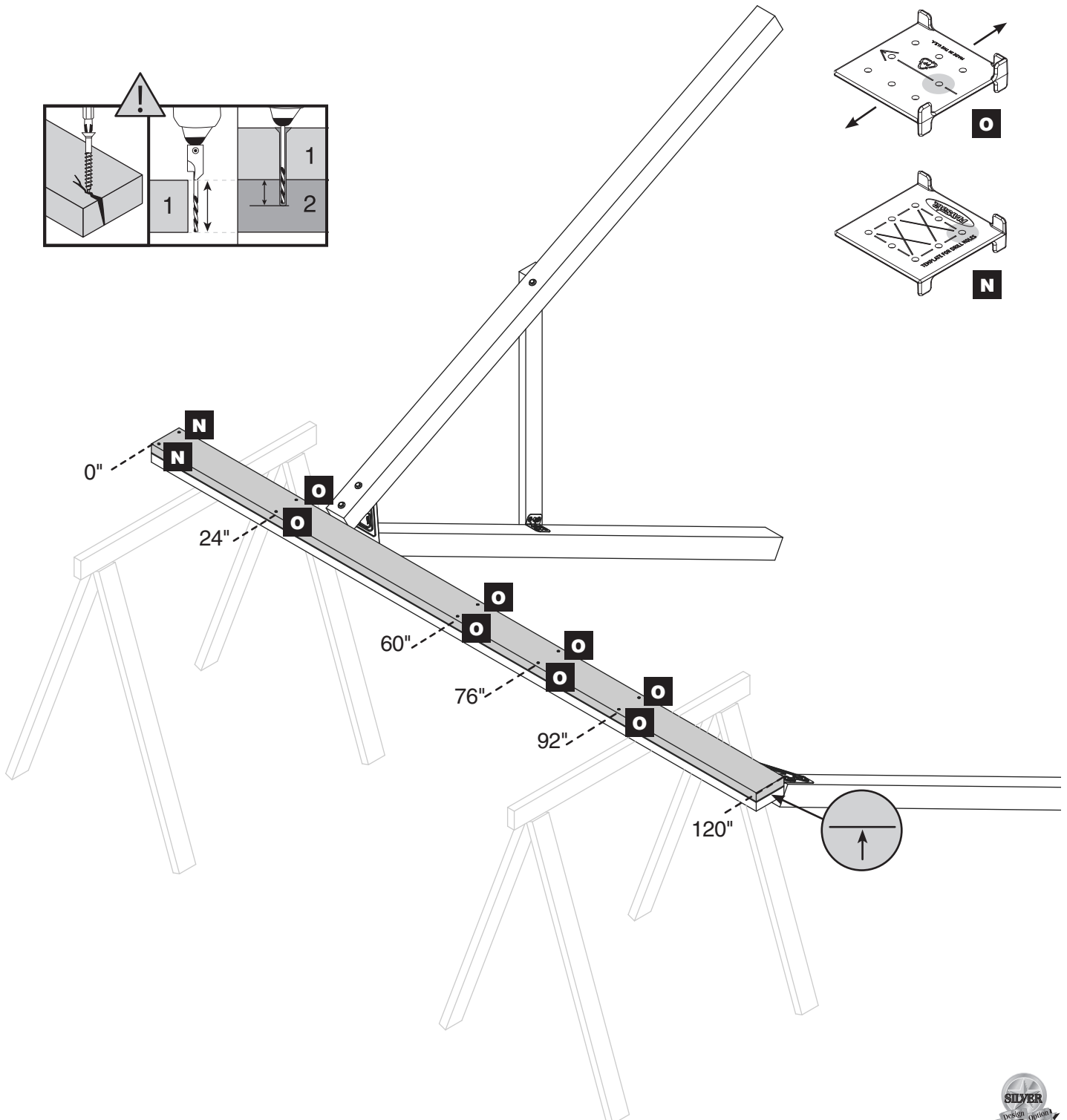
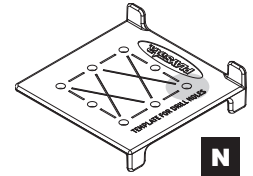
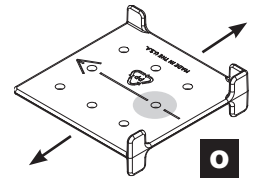
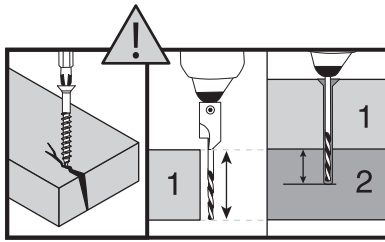

10

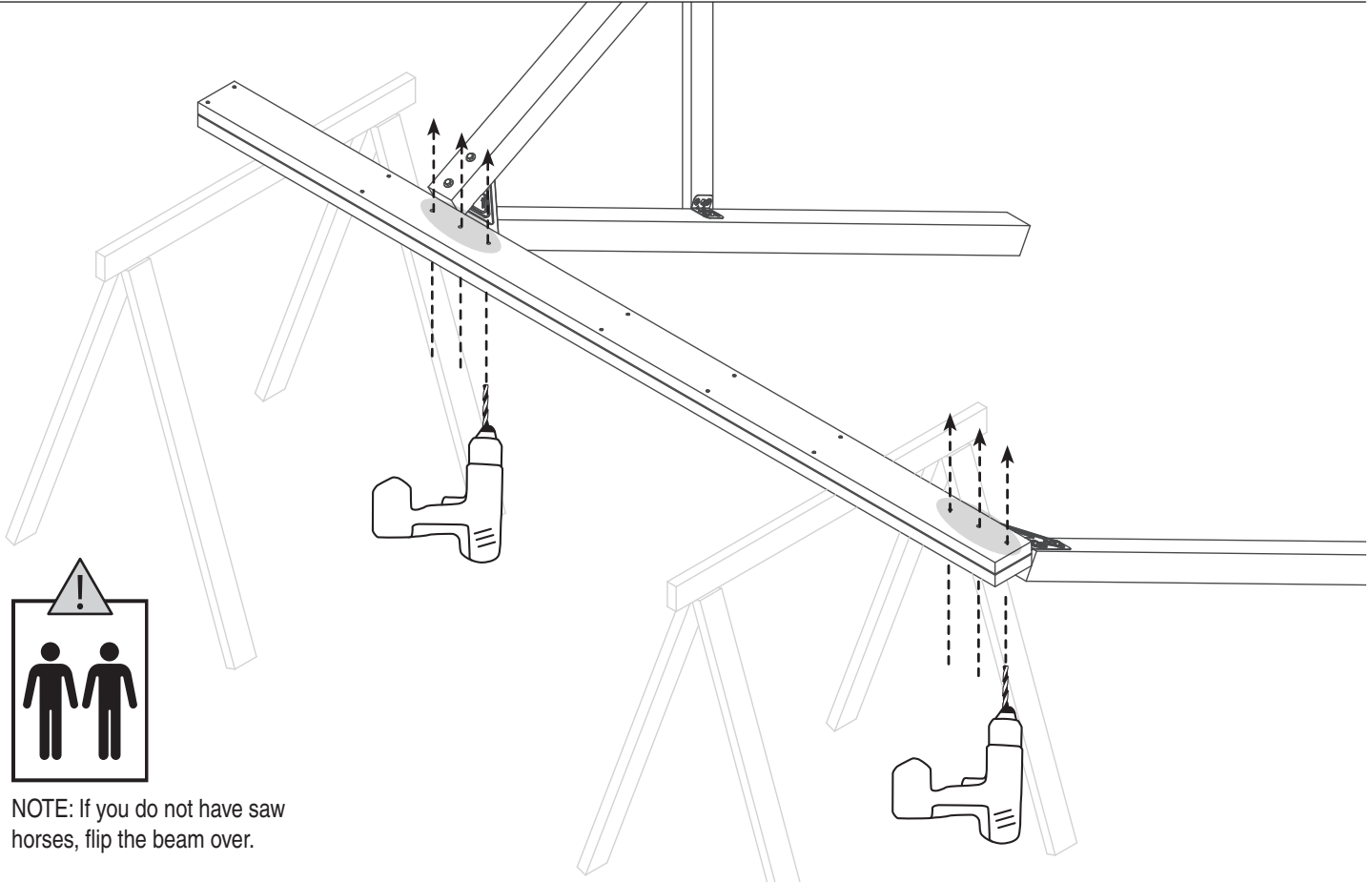
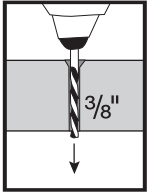

NOTE: If you do not have saw horses, flip the beam over.

11

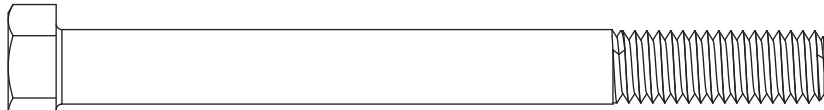

(5) HW 1514 3/8" x 4"

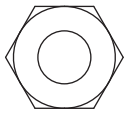
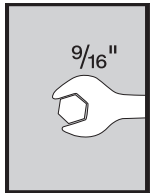

HW 1411
(5) 3/8"

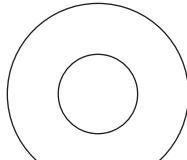

HW 1301
(10) 3/8"

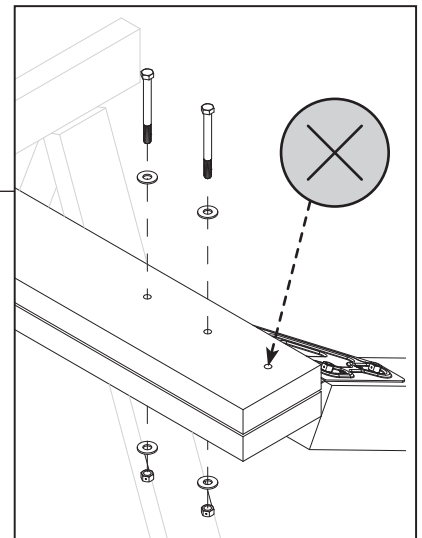
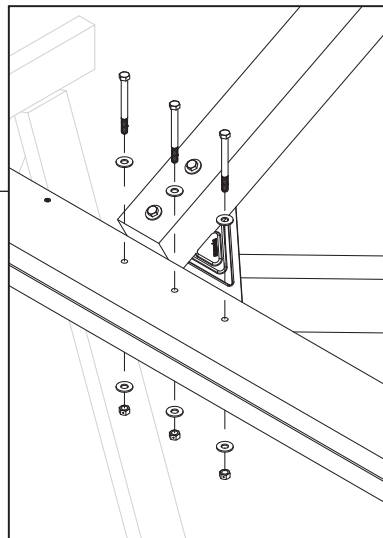

12

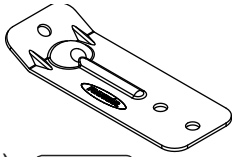

(1) FP 2054

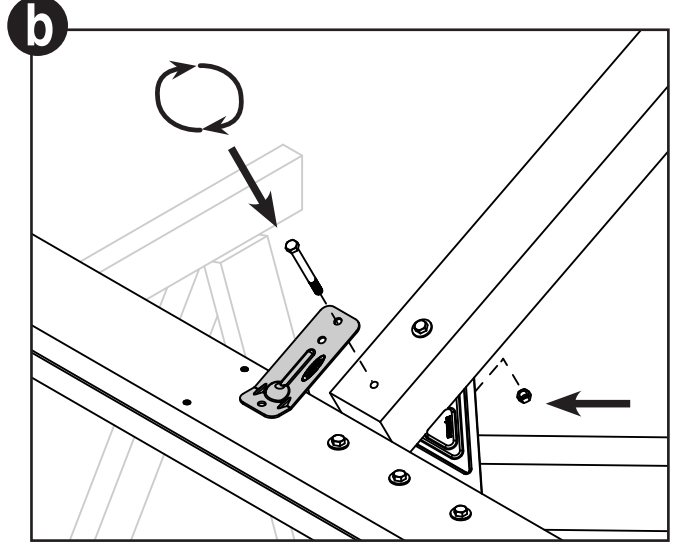
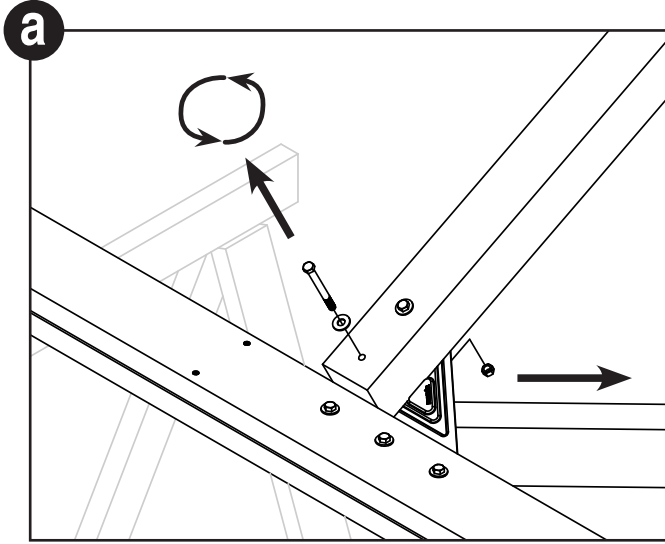
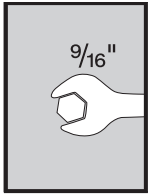

13



(1) 3/8" x 4" HW 1514

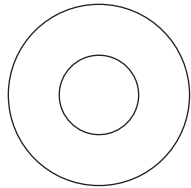
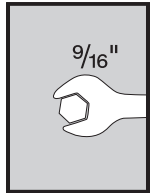
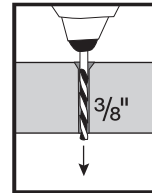

HW 1301
(2) 3/8"

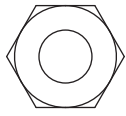

HW 1411
(1) 3/8"

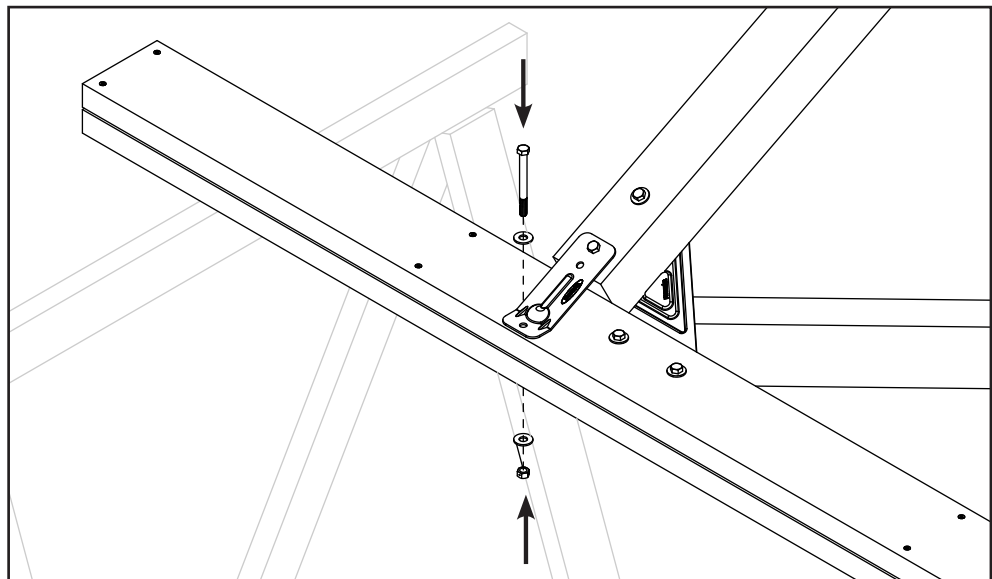
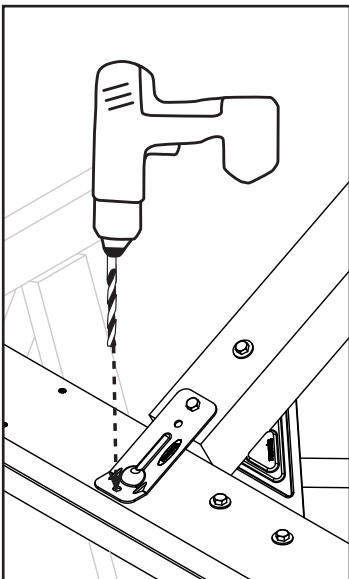

14



(4) FC 3111

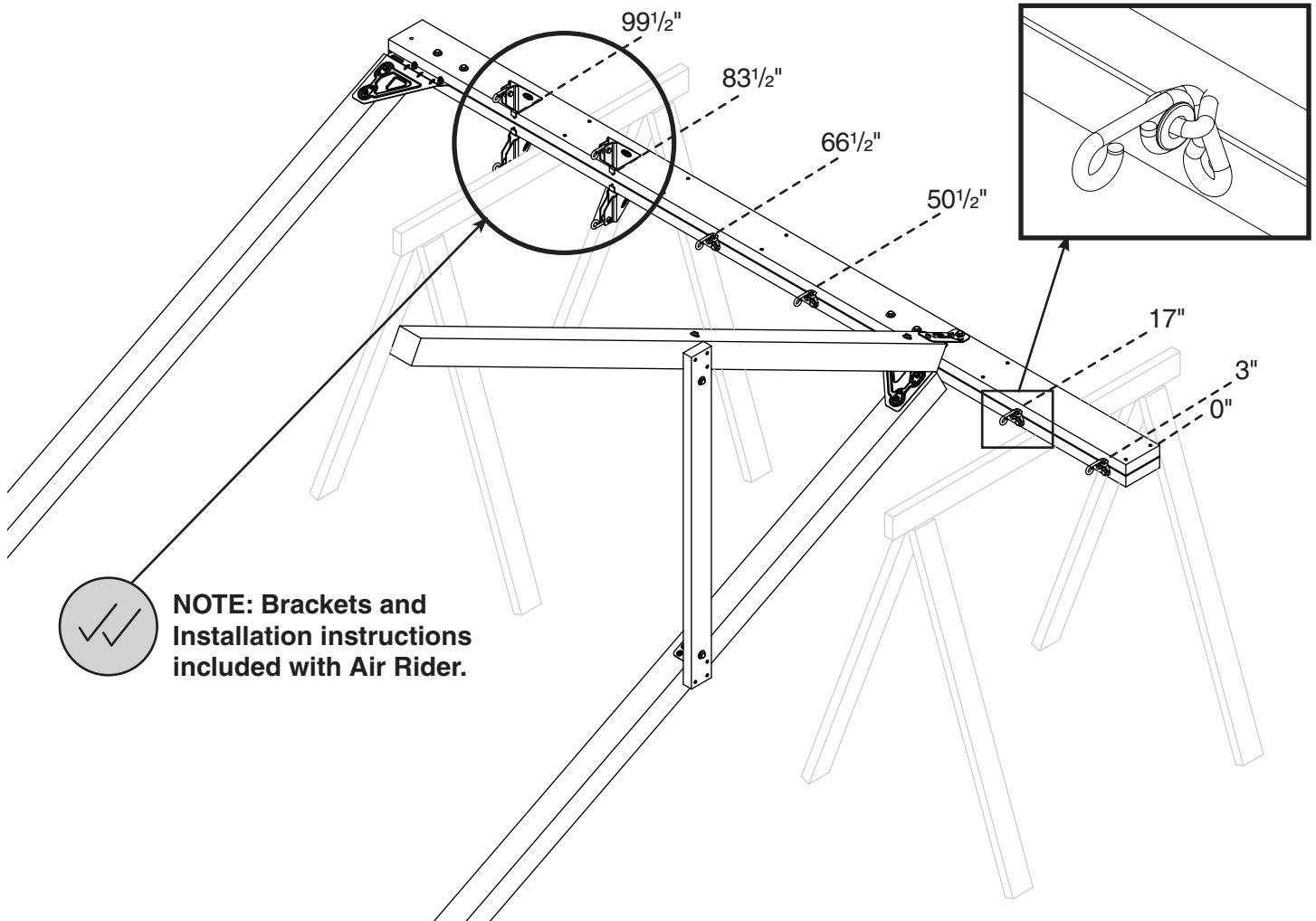
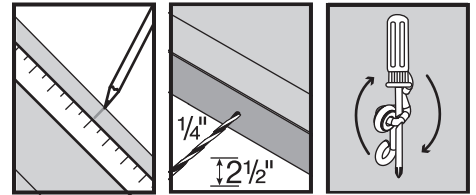

15

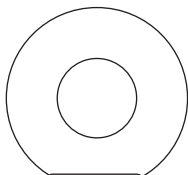

HW 1301
(4) 3/8"

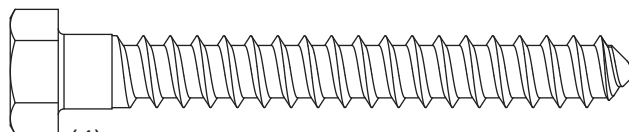

(4) 3/8" x 3" HW 1201

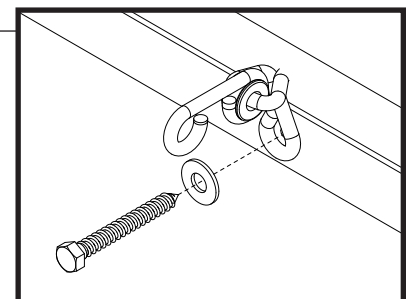
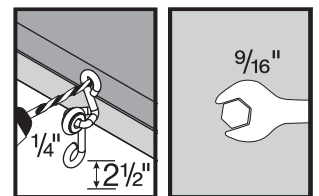

16

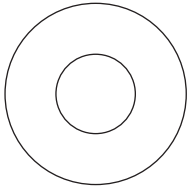

HW 1301
(2) 3/8"

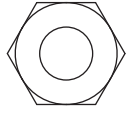

HW 1411
(1) 3/8"

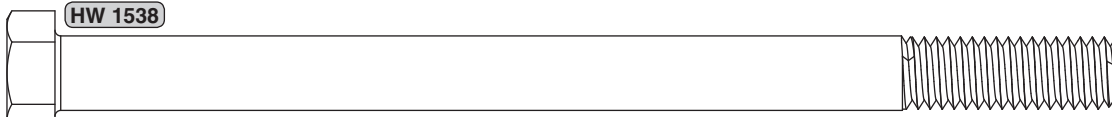
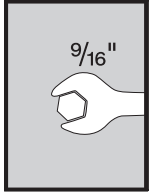
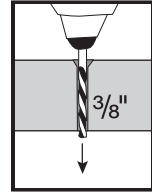
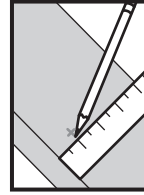

HW 1538

(1) 3/8" x 5 1/2"

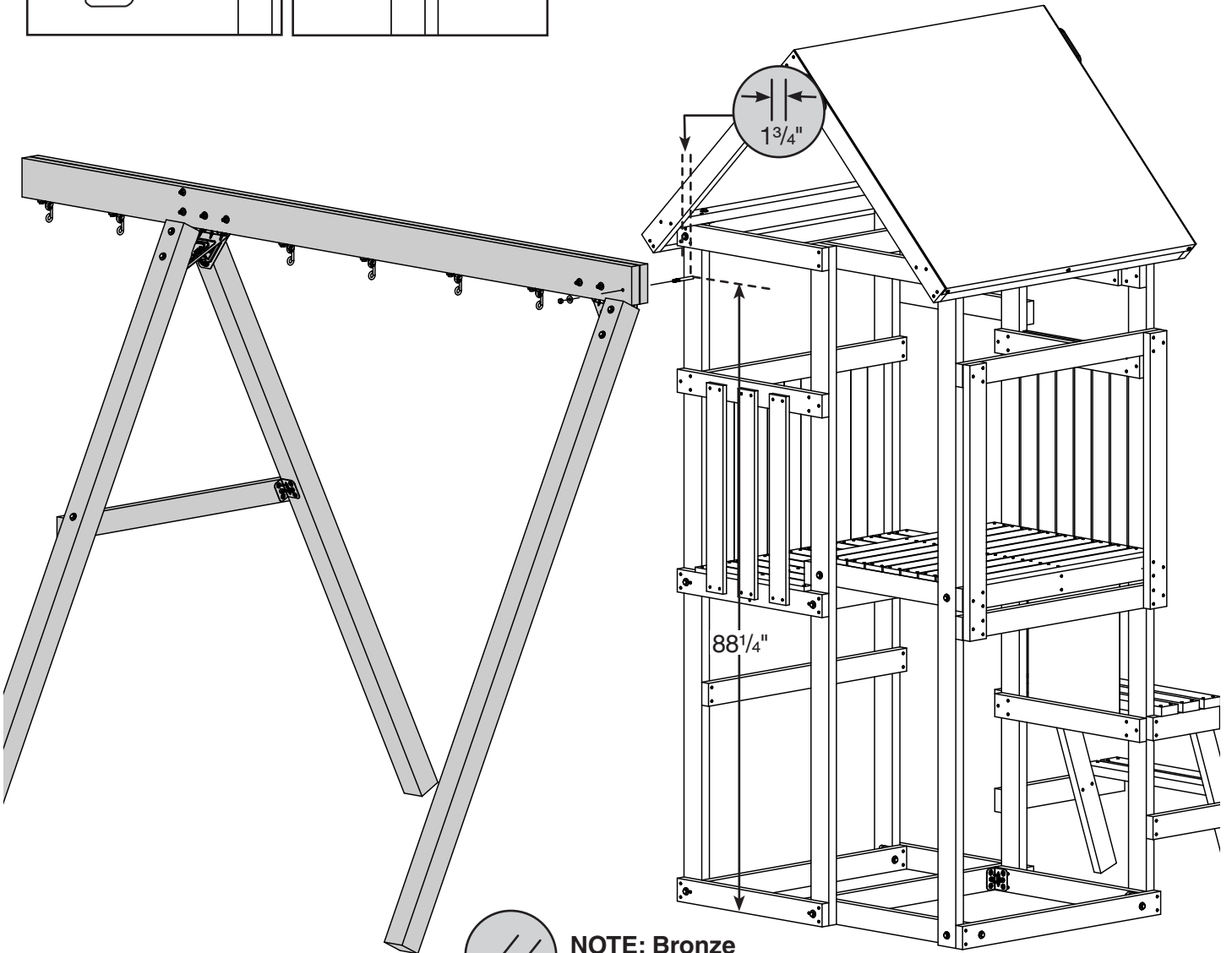
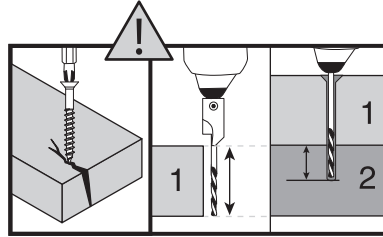
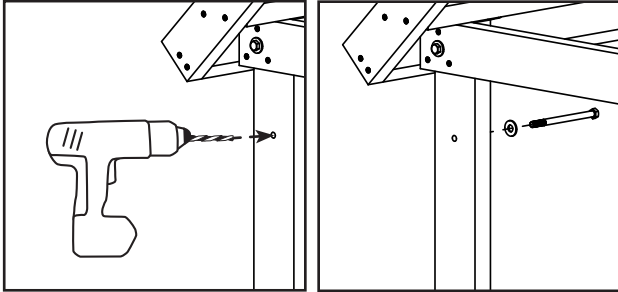

NOTE: Bronze tower pictured.



17

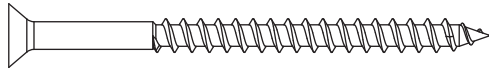

(4) HW 1204 #8 x 2 1/2"



(2) 2" x 4" x 31 1/2"

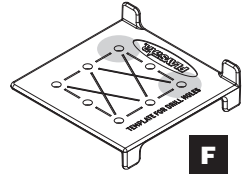
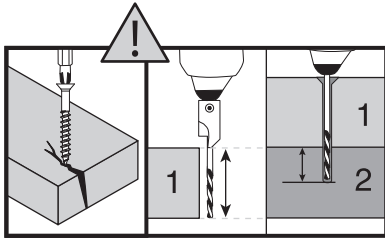
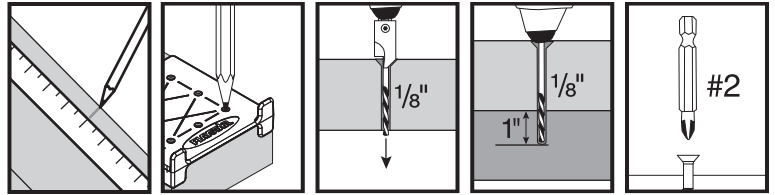

NOTE: Bronze tower pictured.

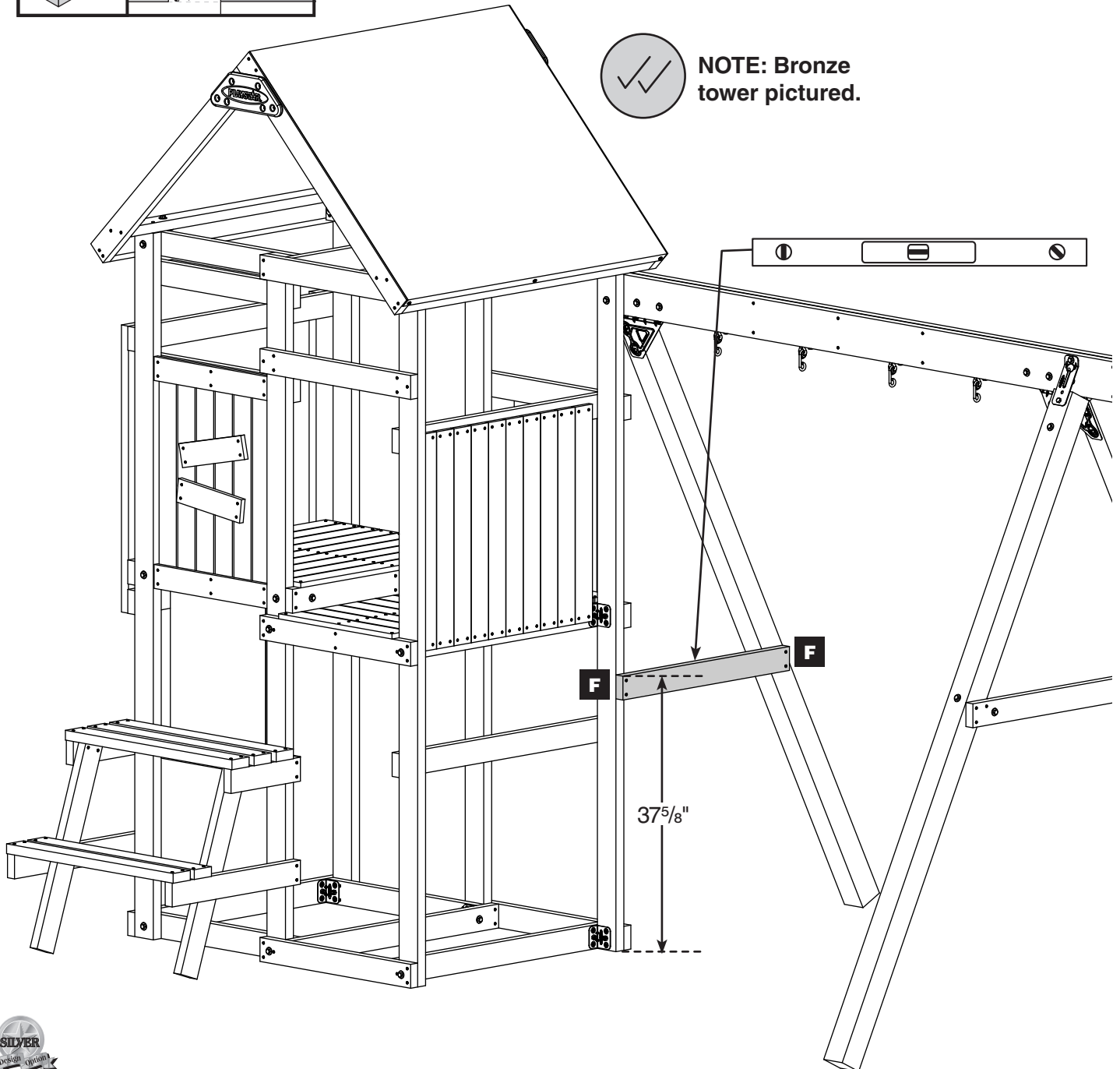

18

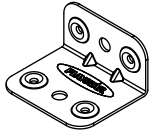

(2) SA 4496

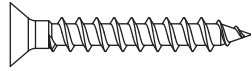

(8) HW 1213 #8 x 1 1/4"

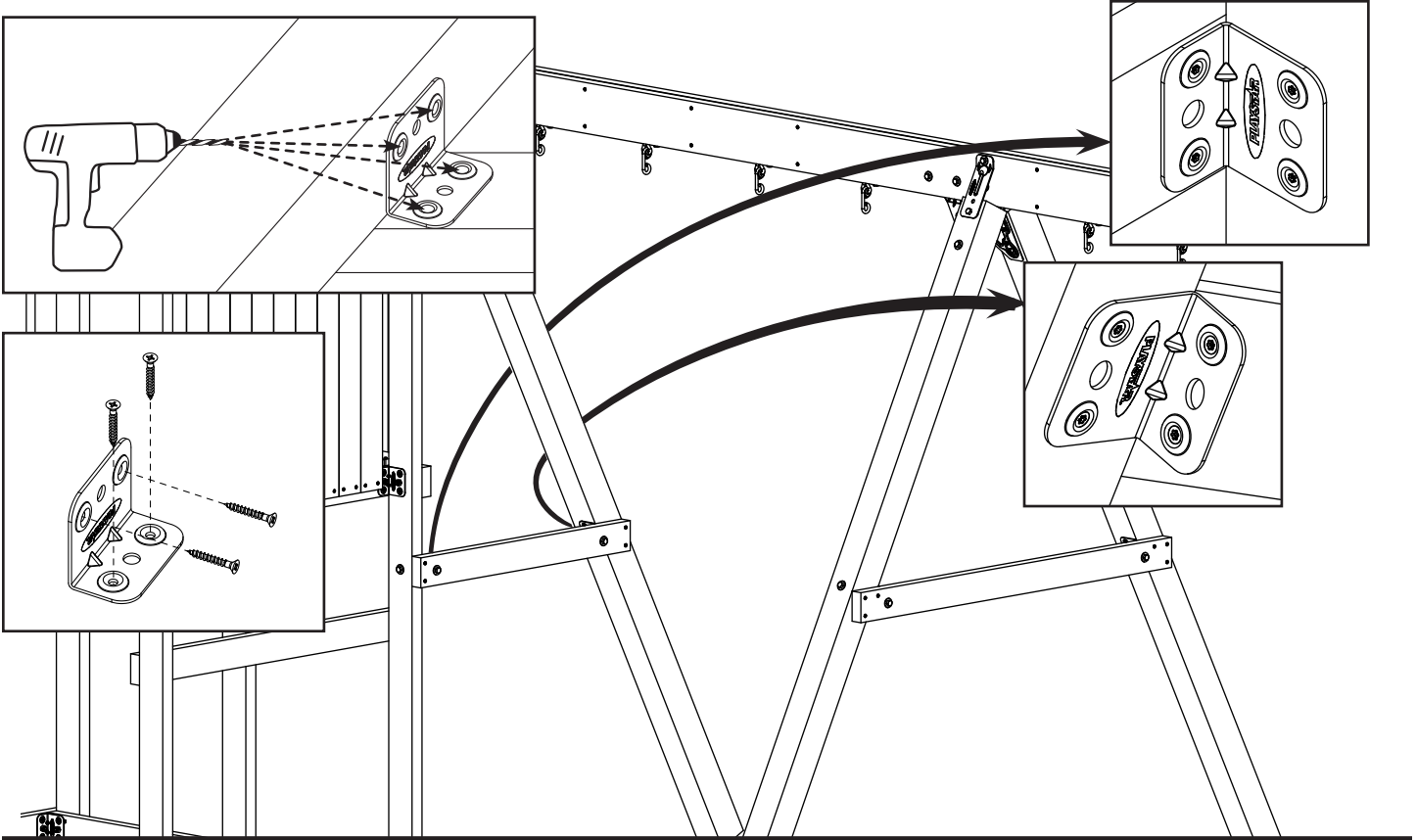
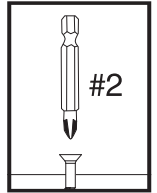
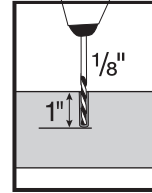

19

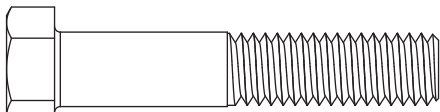

(3) HW 1528 3/8" x 2"

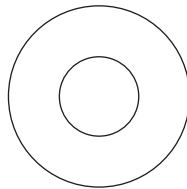

HW 1301
(4) 3/8"

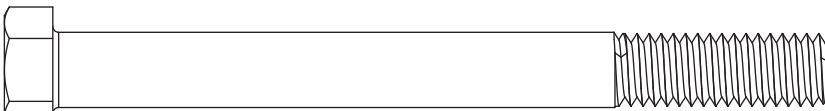
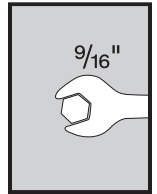
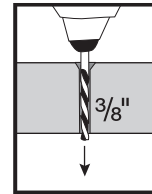

(1) HW 1514 3/8" x 4"

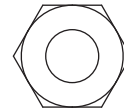

HW 1411
(4) 3/8"

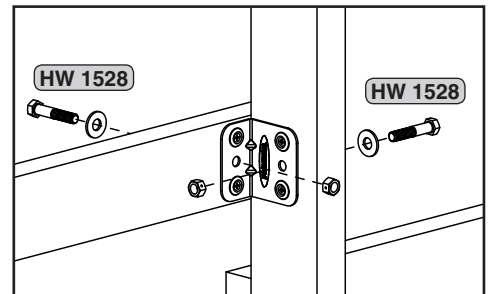
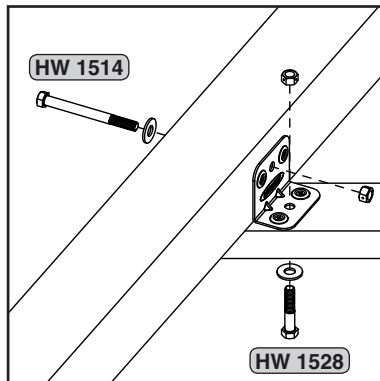
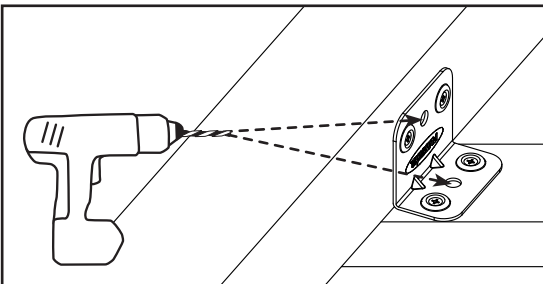

Combo Wall

1

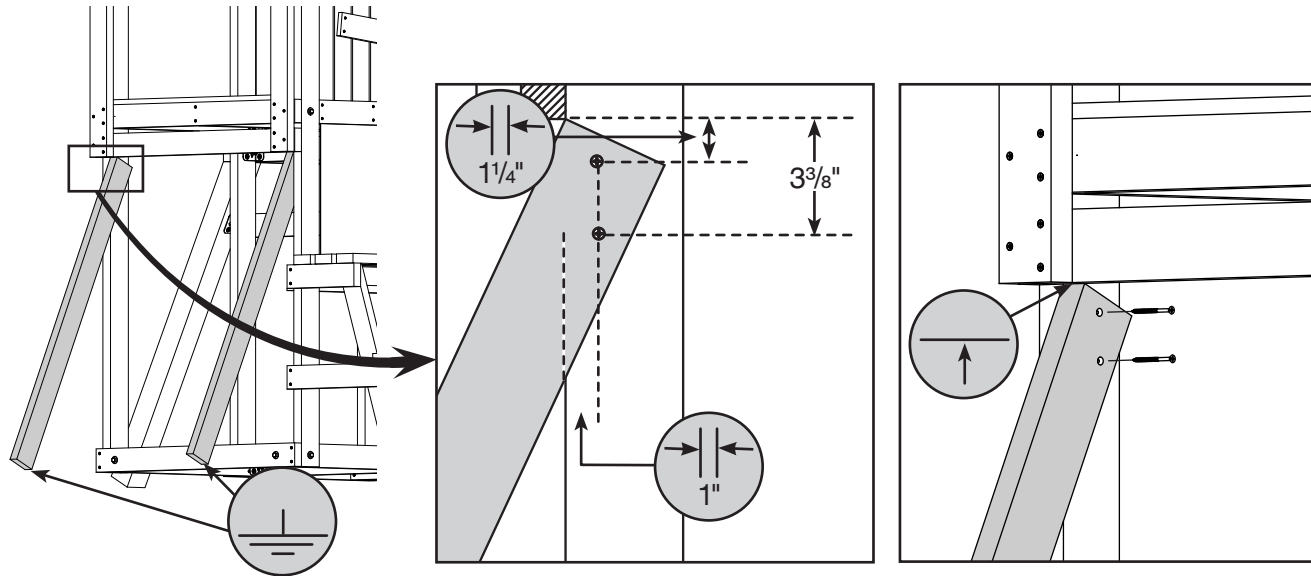
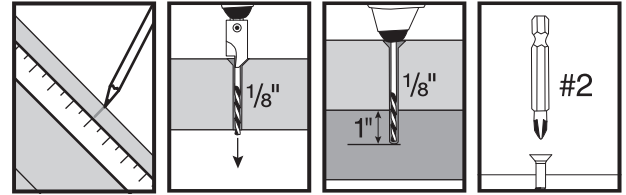
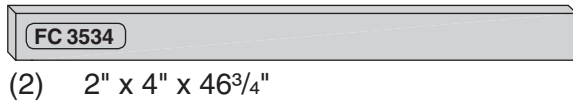
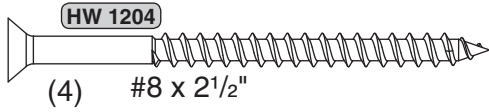

2

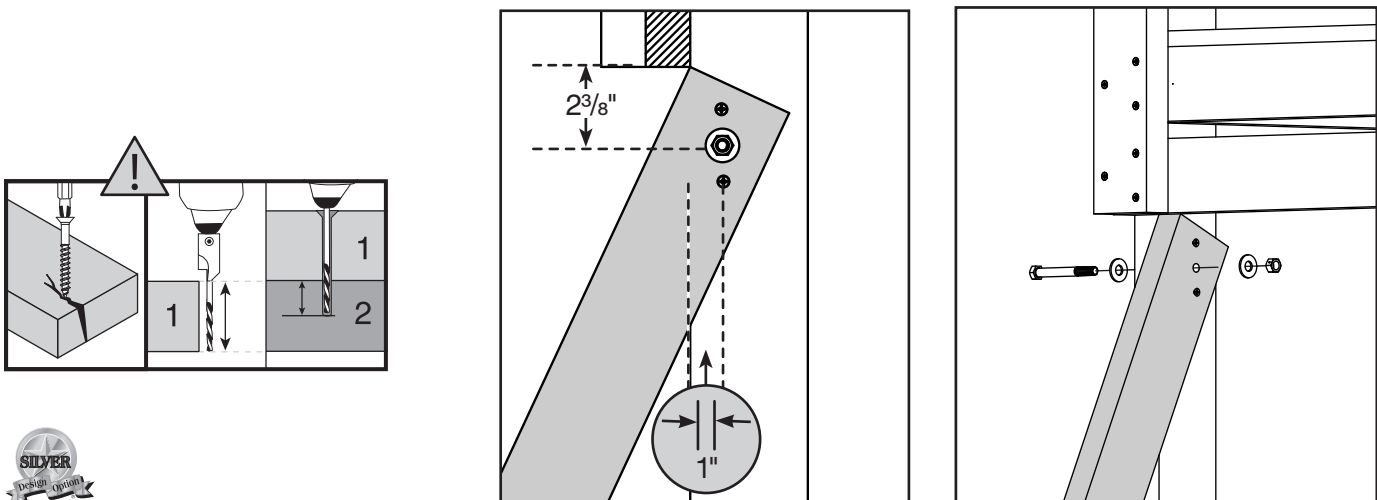
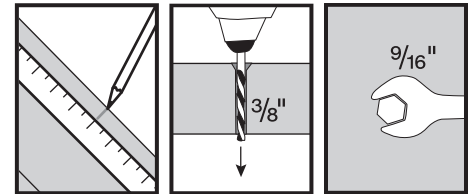
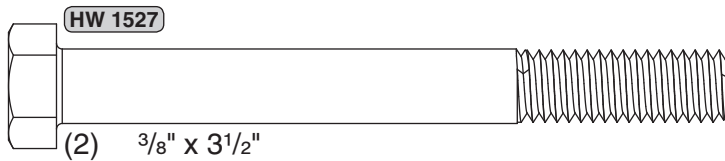
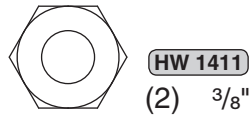
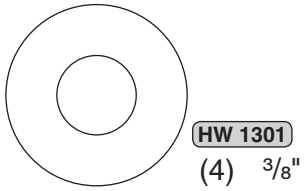

3

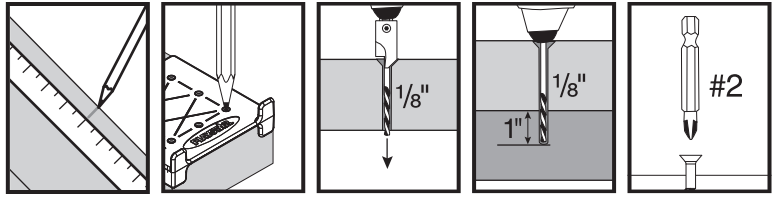
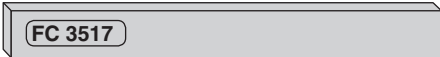
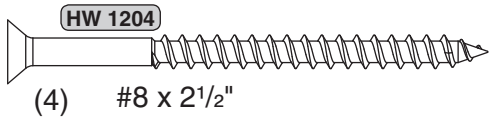

(1) 2" x 4" x 35 7/8"

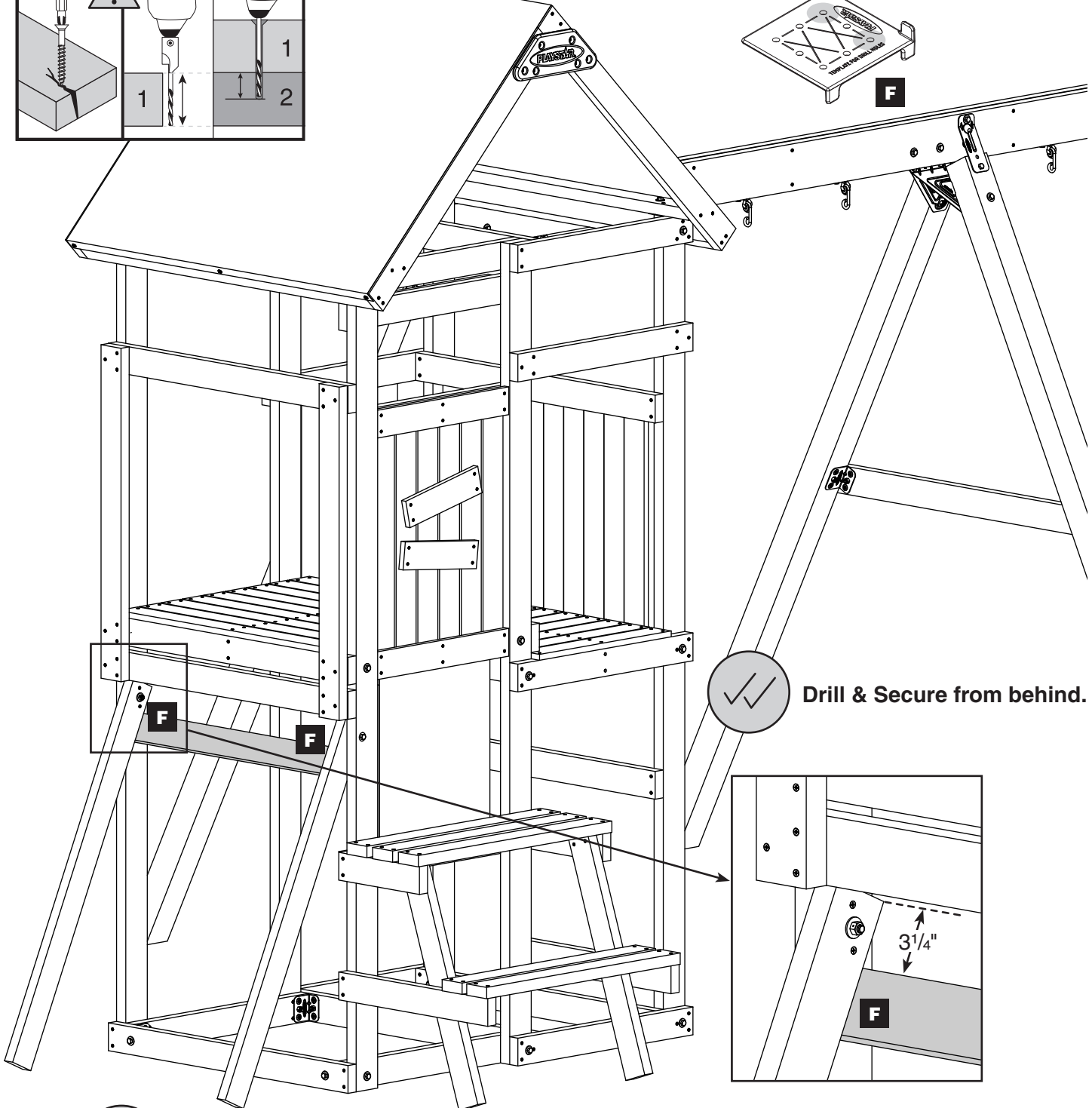
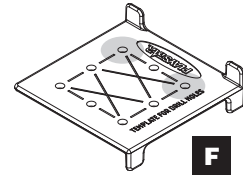
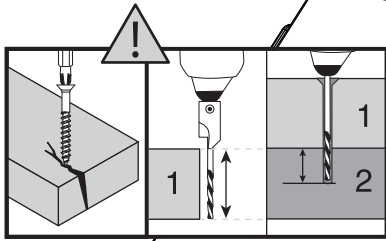

NOTE: Bronze tower pictured.



4

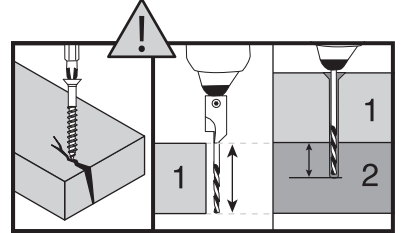
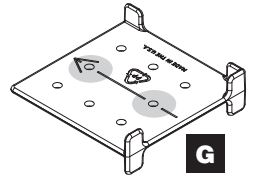
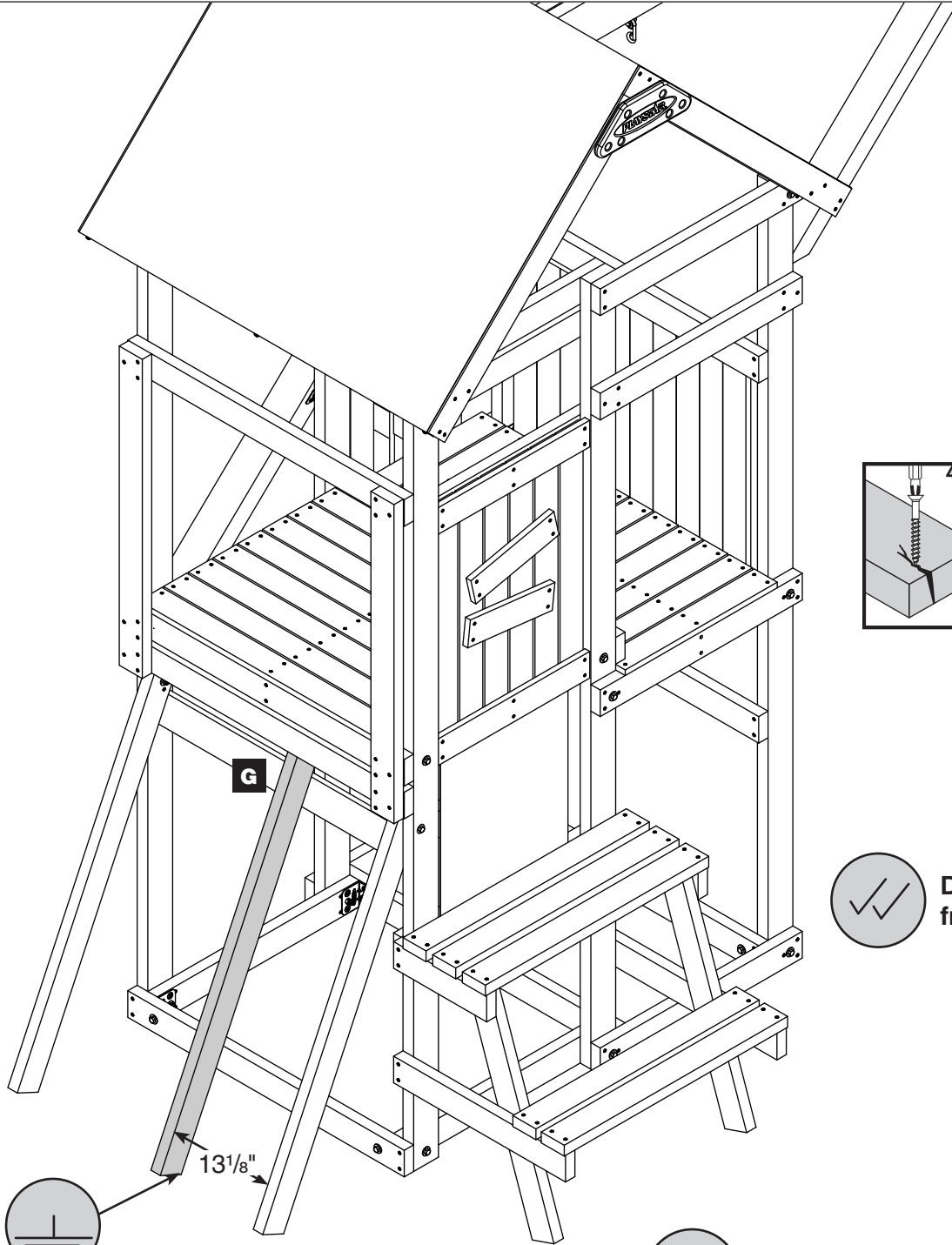
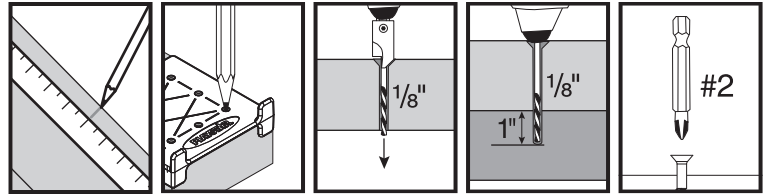
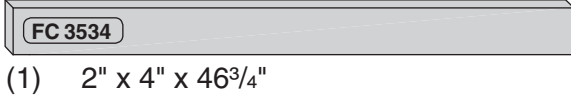
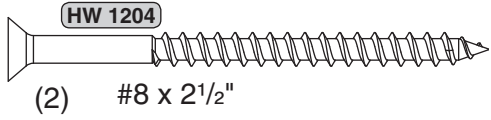

✓✓ Drill & Secure from behind.

✓✓ NOTE: Bronze tower pictured.



5

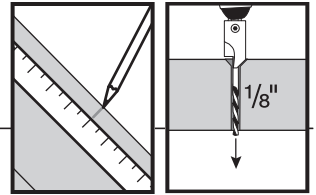

NOTE: Bronze tower pictured.

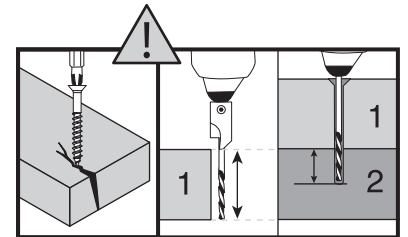
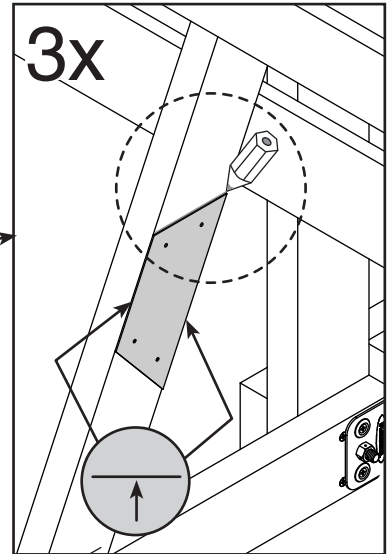
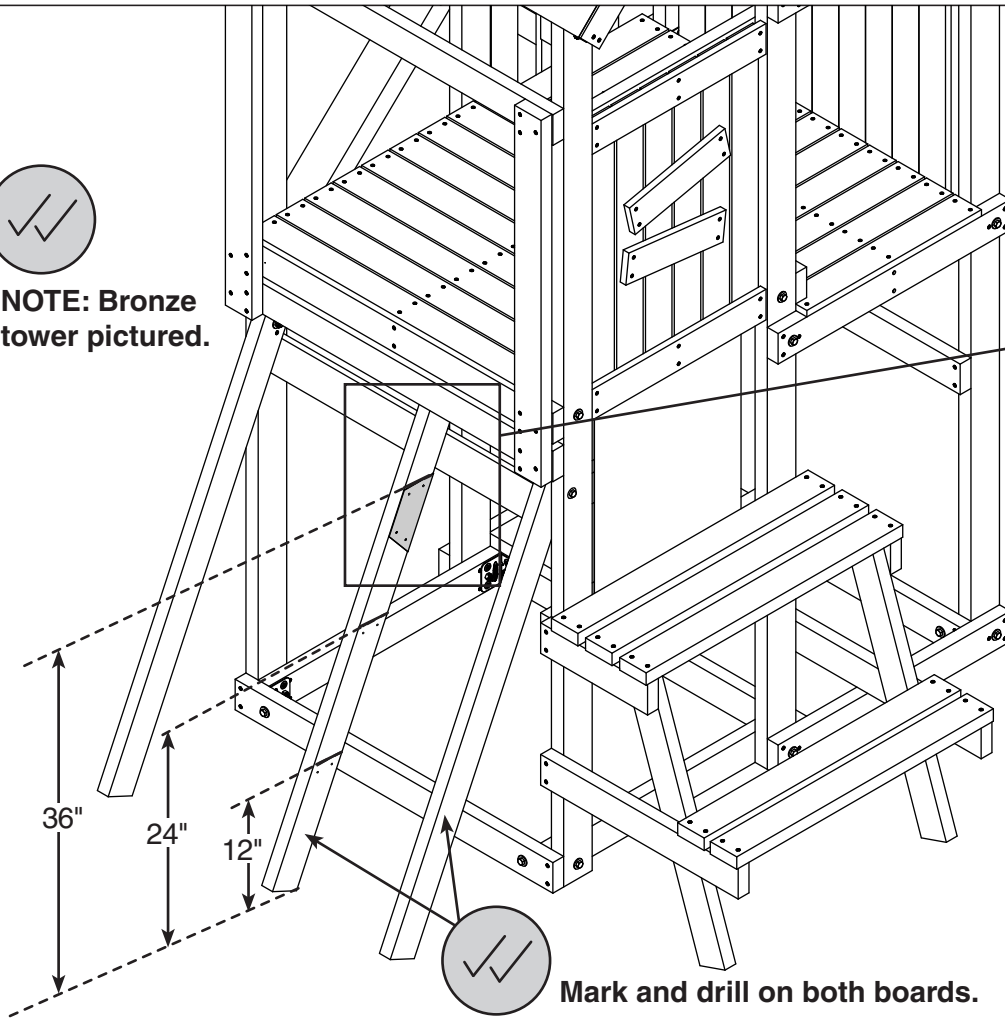

Top- Use for Right Side Marking



Cut out Template for step 5.
Use to mark top edge and top
drill holes at each interval.

Top- Use for Left Side Marking

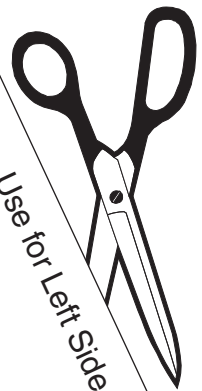

6

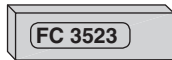
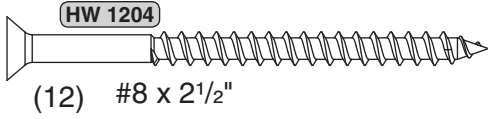

(3) 2" x 4" x 13 1/8"

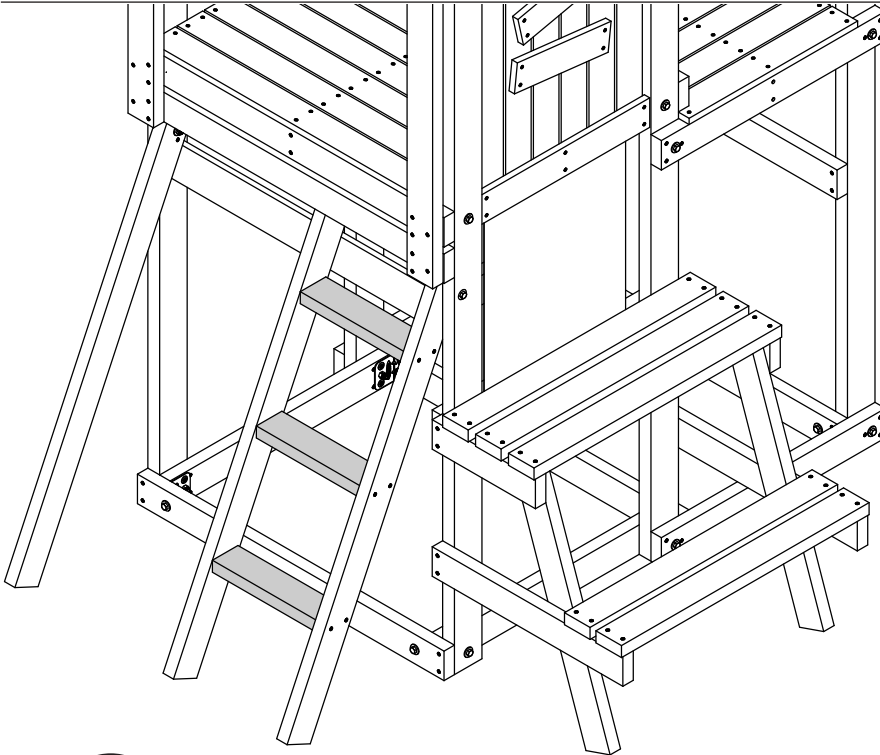
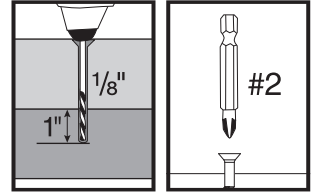

Align top of boards to the line marked with template in step 5.



NOTE: Bronze tower pictured.

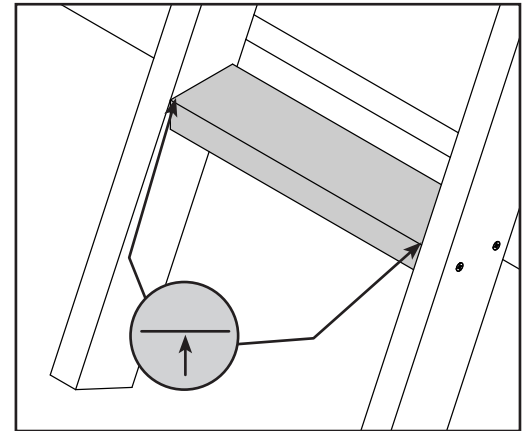

This portion left blank intentionally.

7

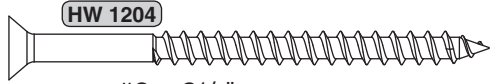

(4) #8 x 2 1/2"



(1) 2" x 4" x 18 1/2"

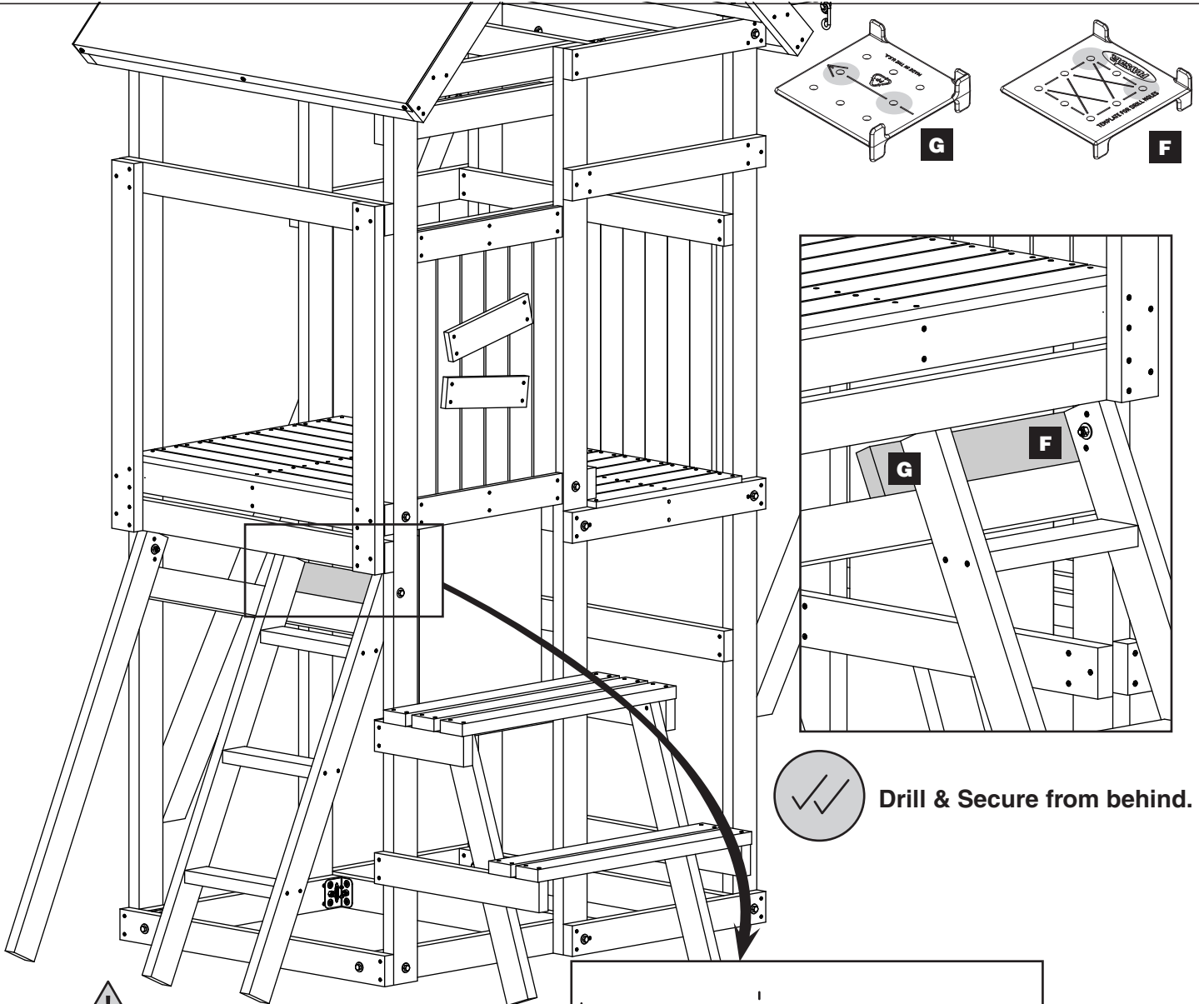
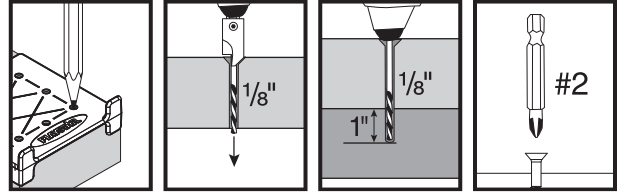

Drill & Secure from behind.

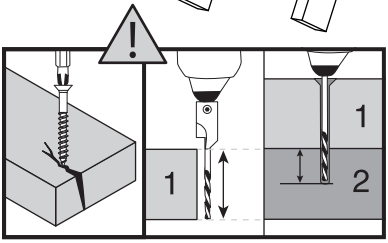

NOTE: Bronze tower pictured.

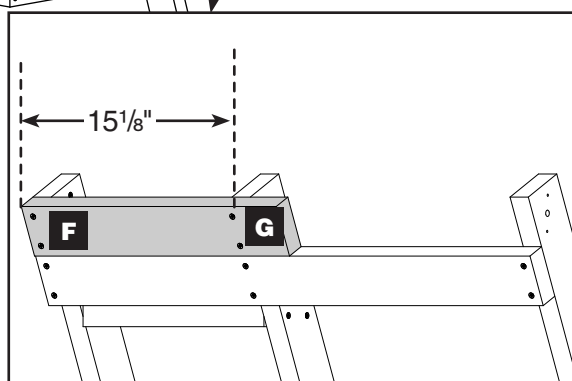

8

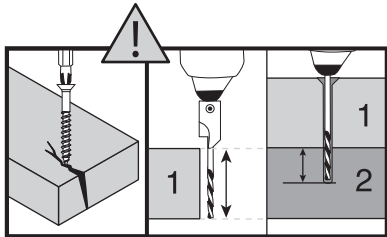
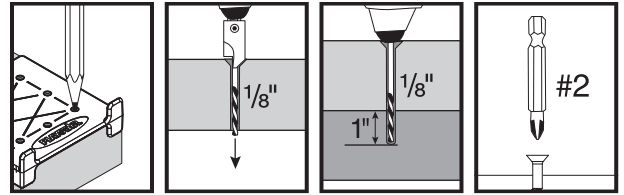
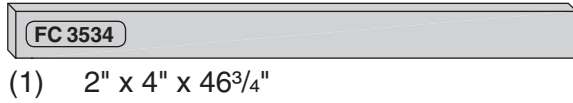
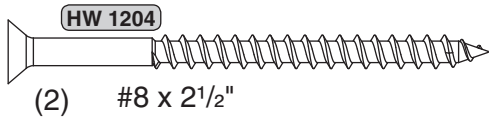

Drill & Secure from behind.

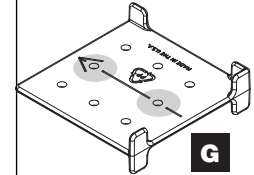
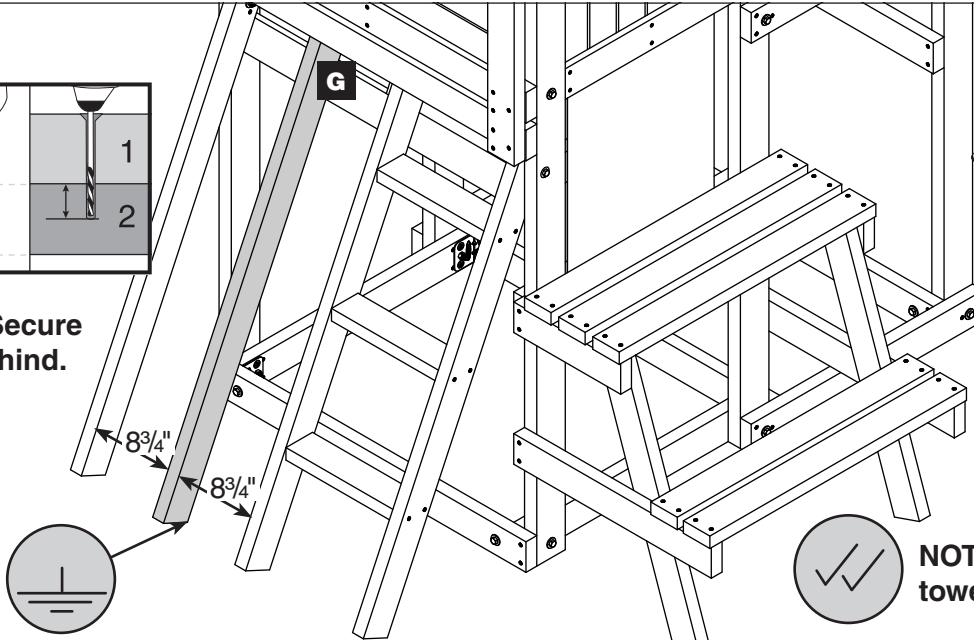

NOTE: Bronze tower pictured.

9

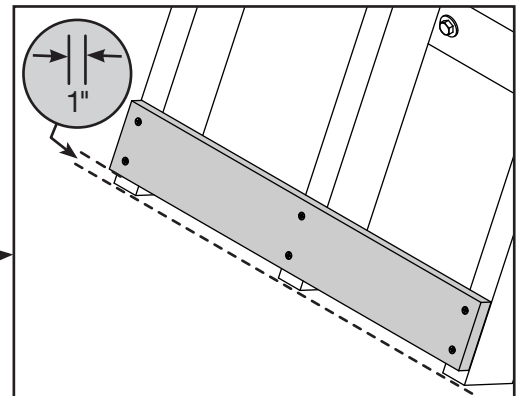
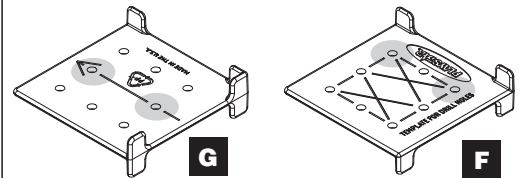
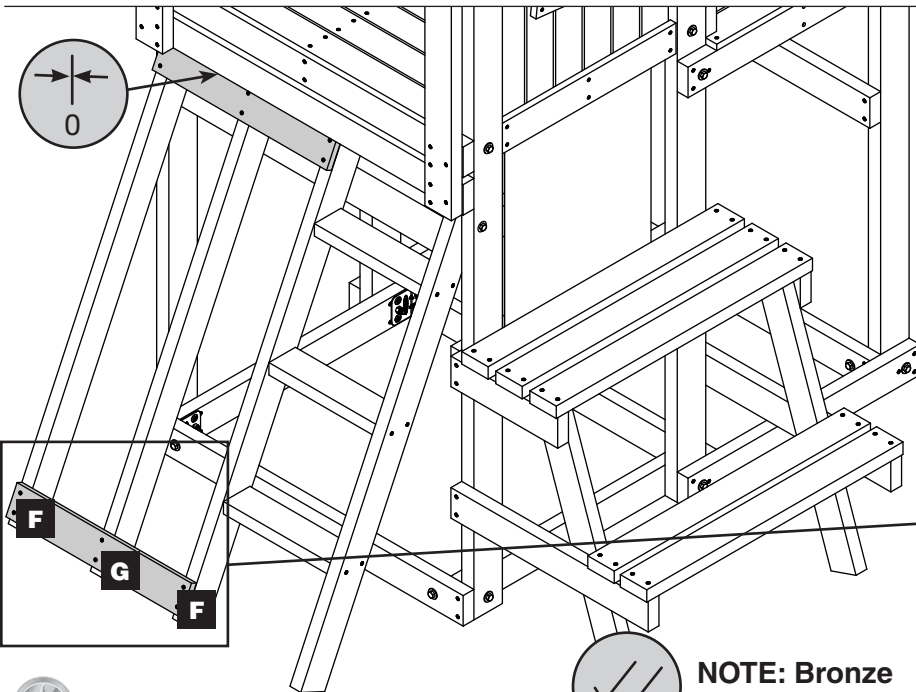
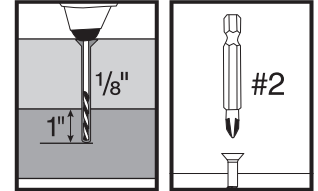
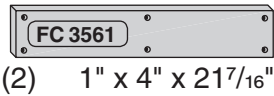
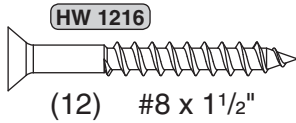

NOTE: Bronze tower pictured.



10

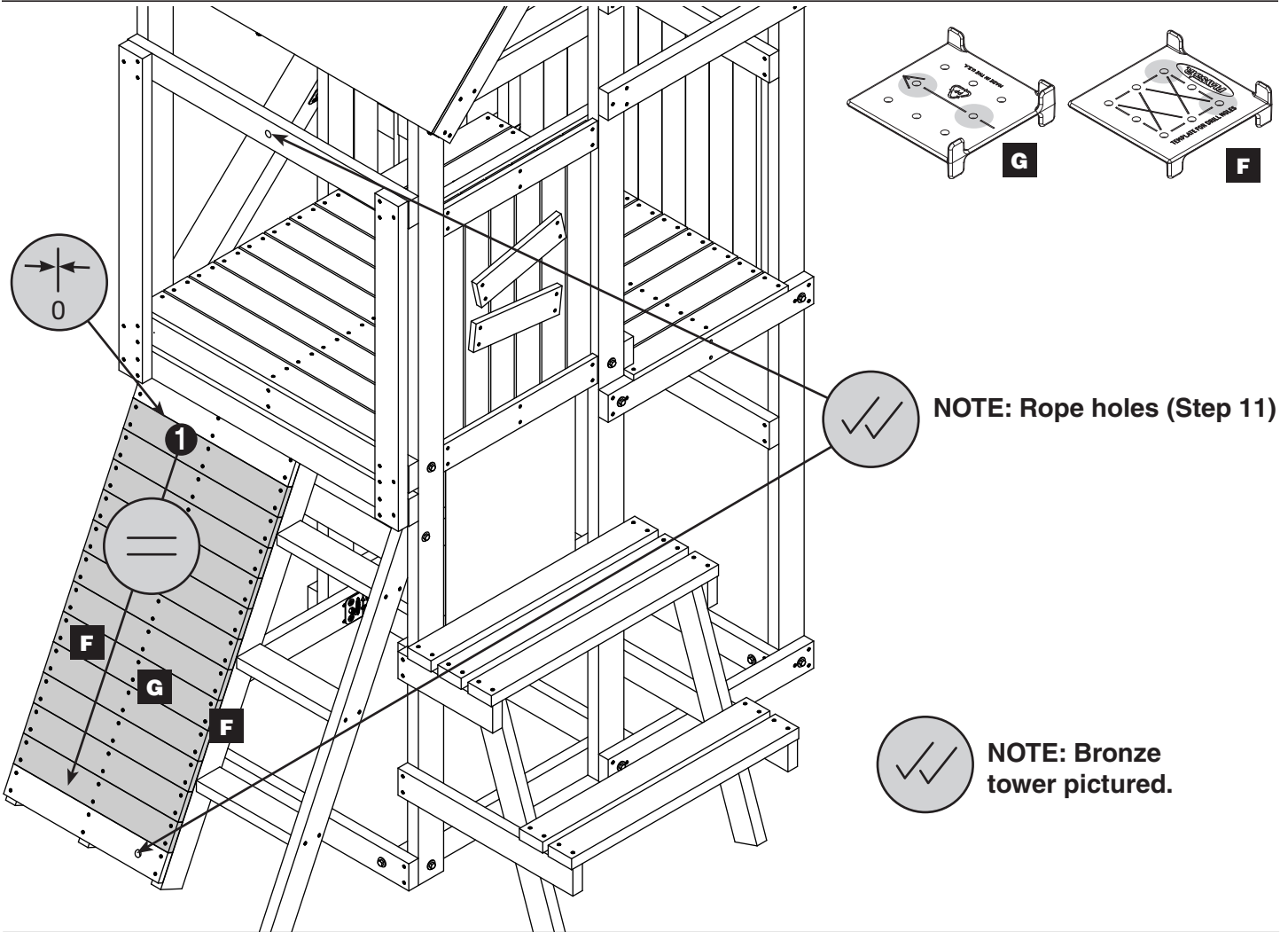
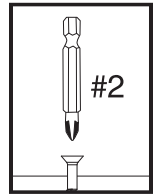
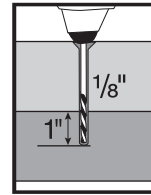
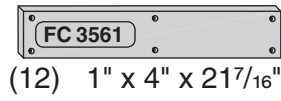
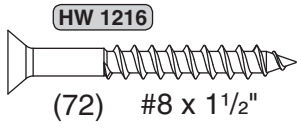

11

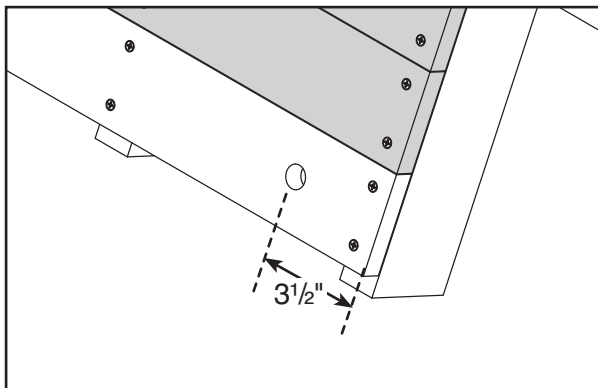
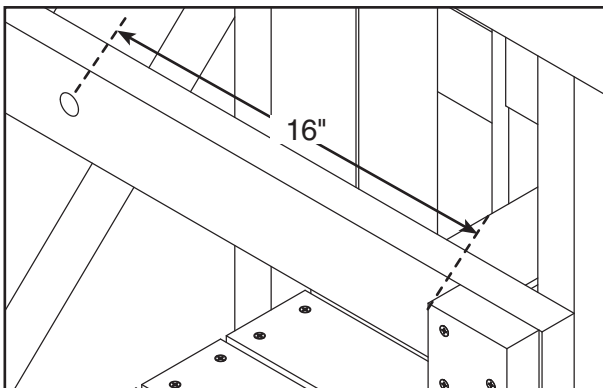
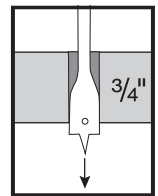
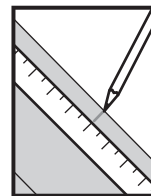

Monkey Rings

1

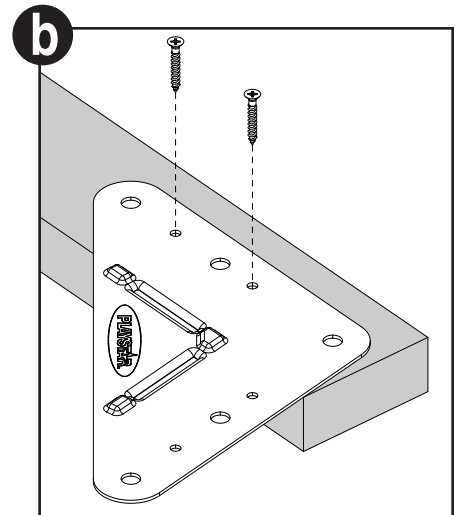
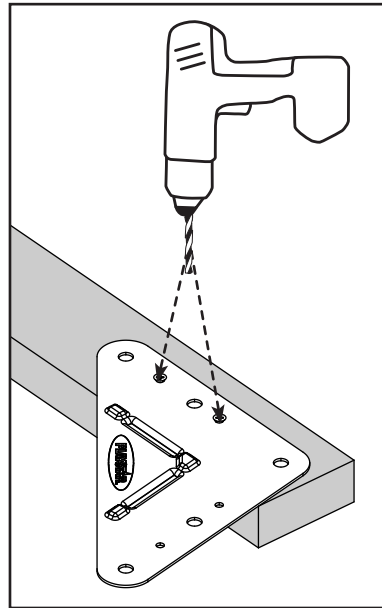
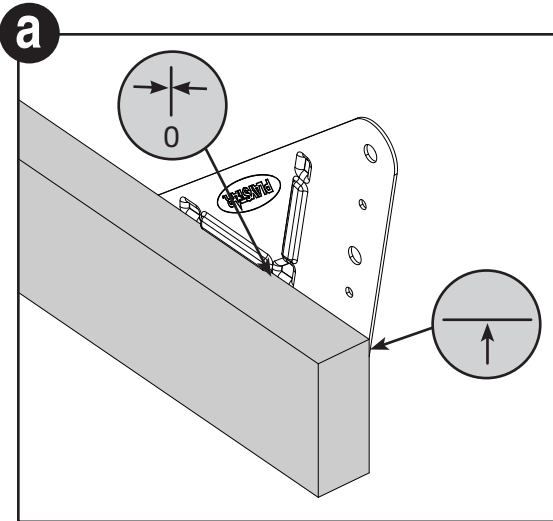
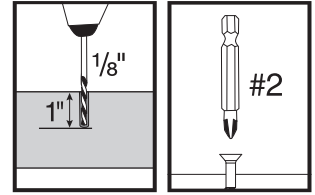
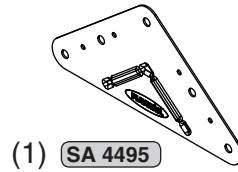
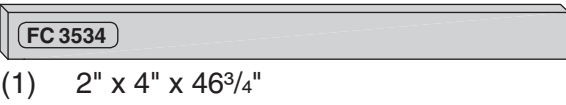
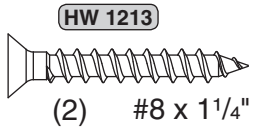

2

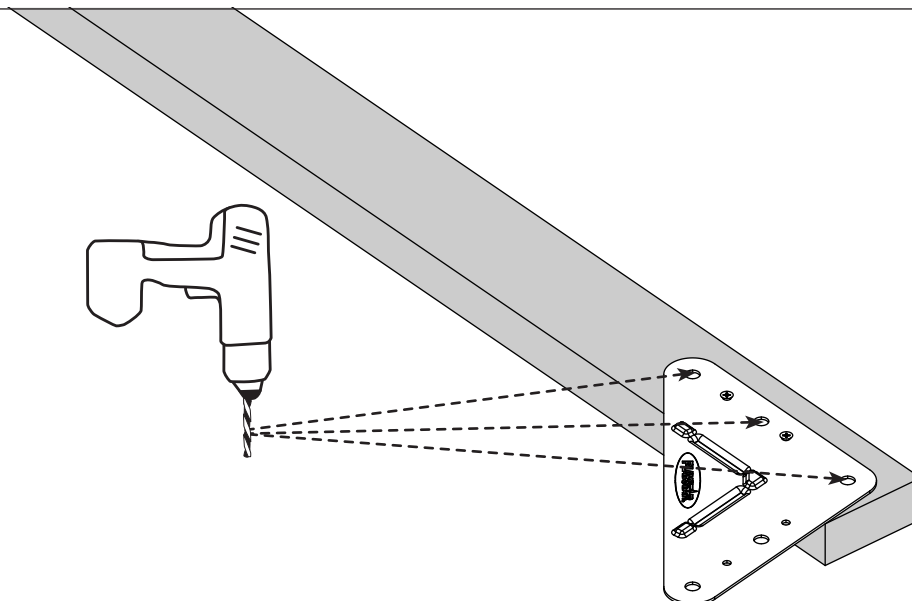
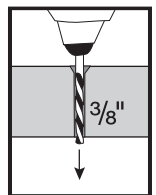

3

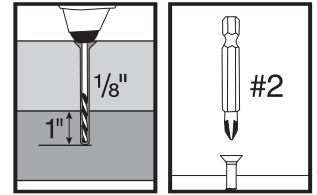
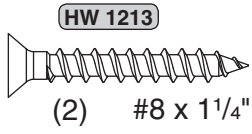

(1) 2" x 4" x 8'

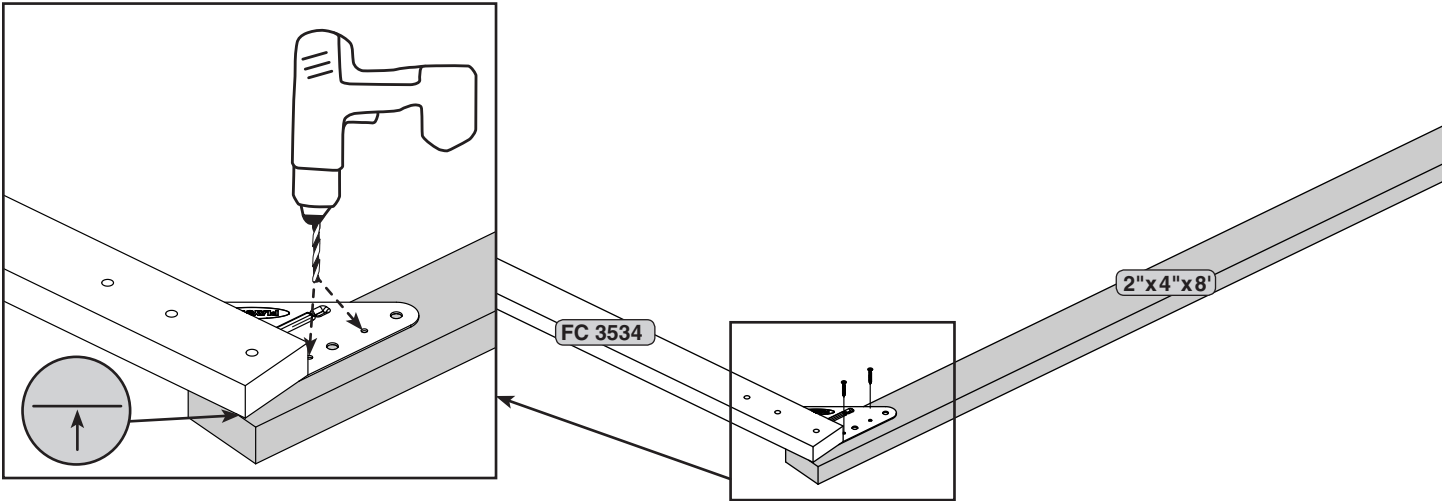

4

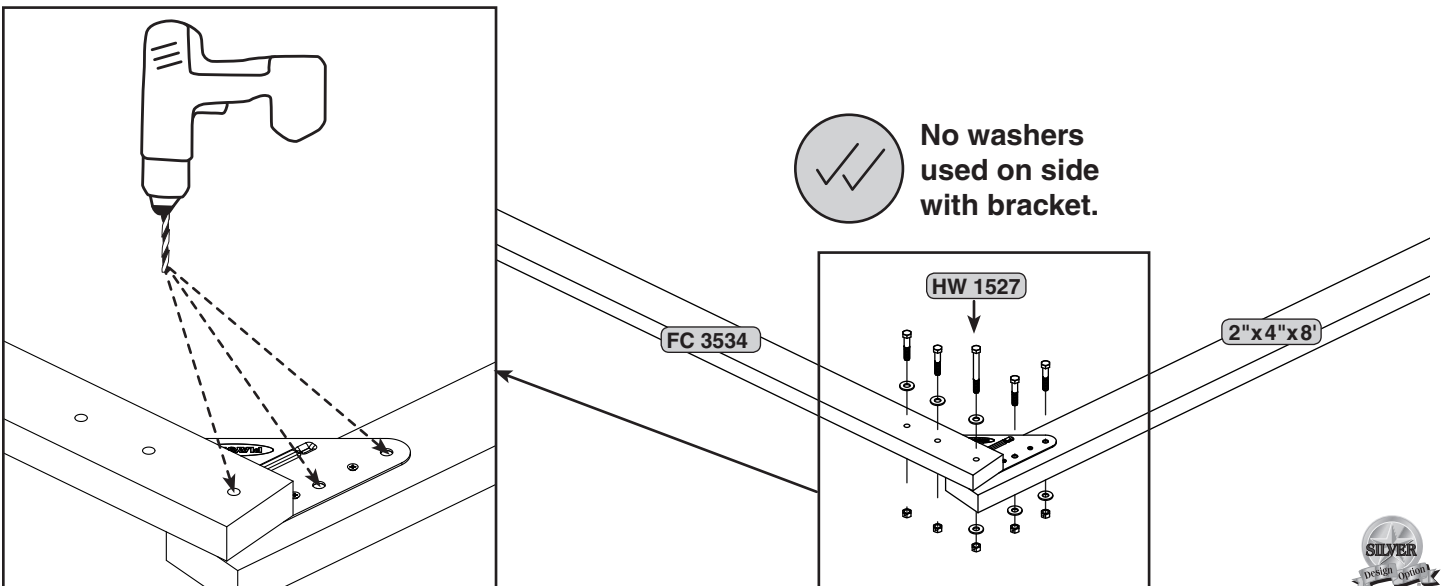
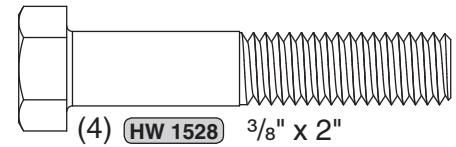
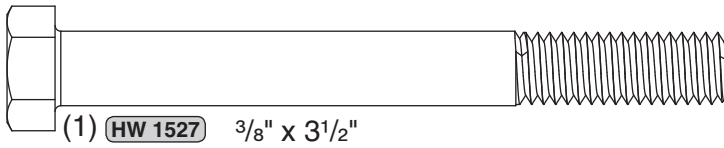
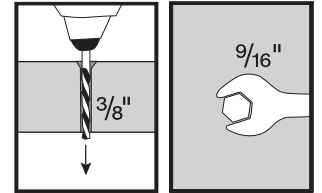
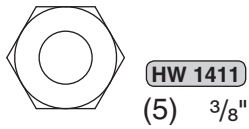
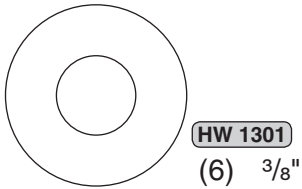

5

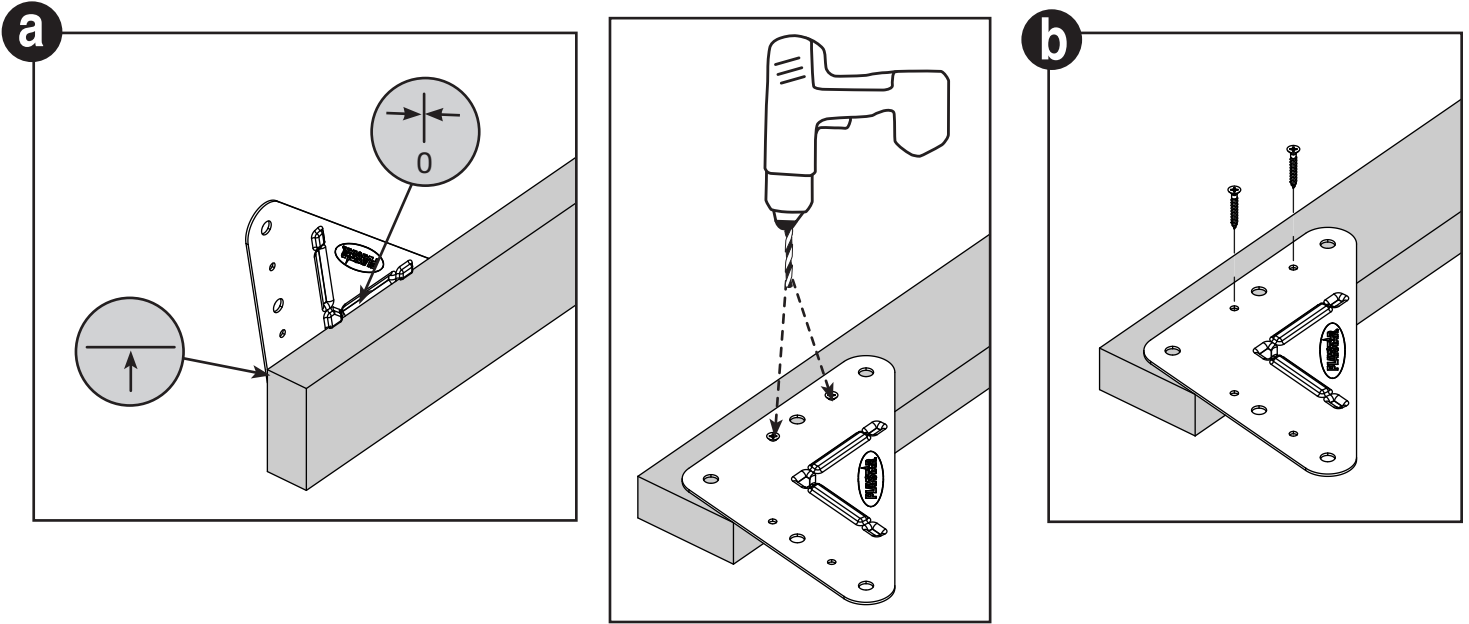
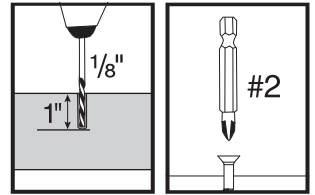
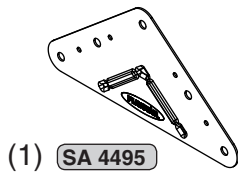
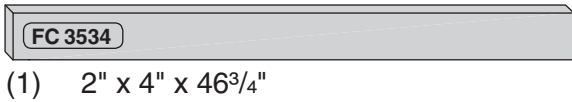
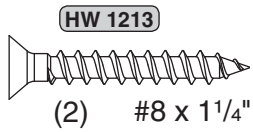

6

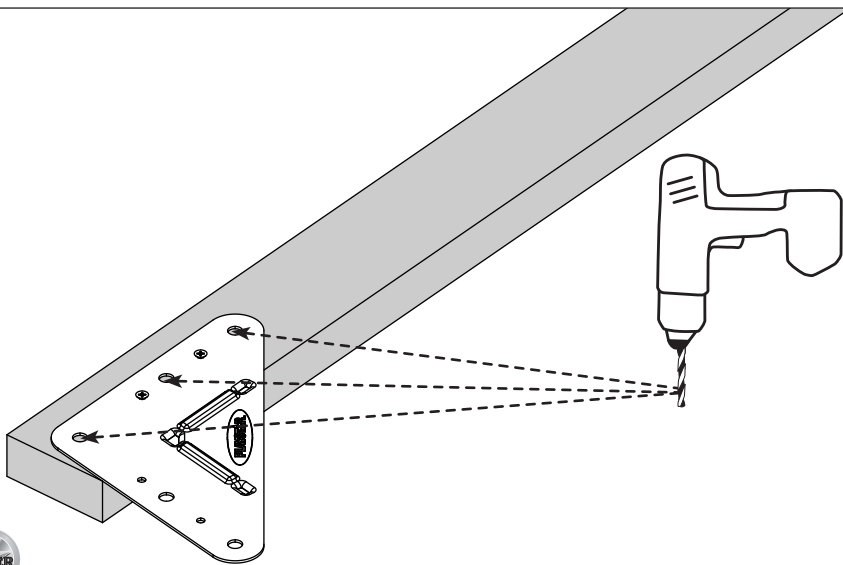
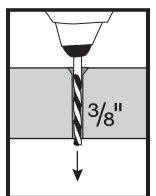

7

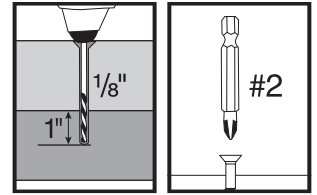
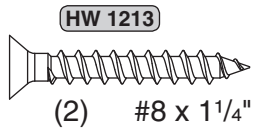

(1) 2" x 4" x 8'

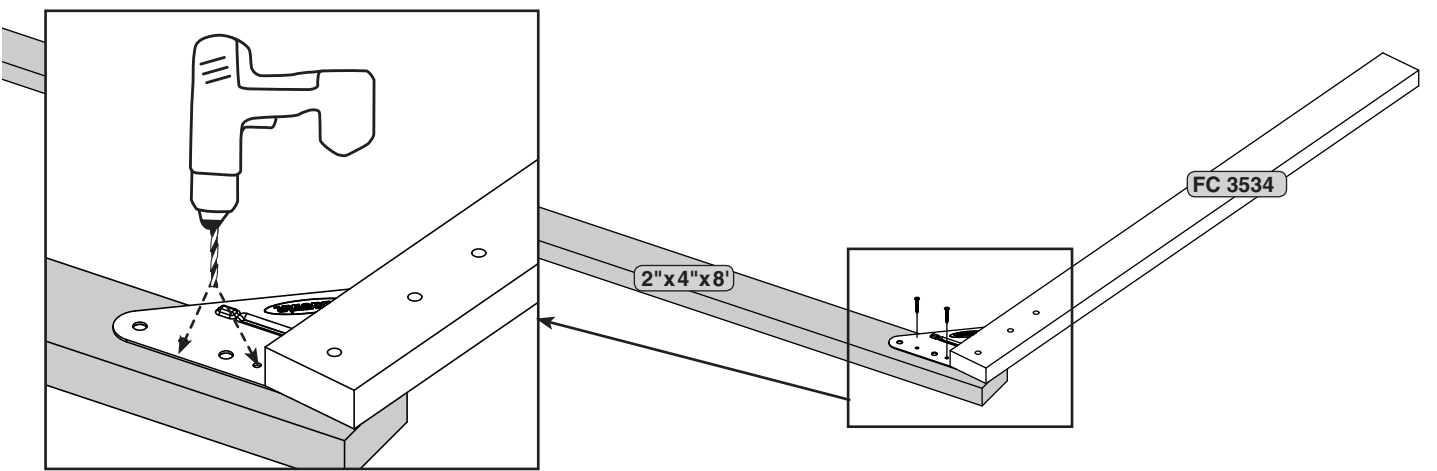

8

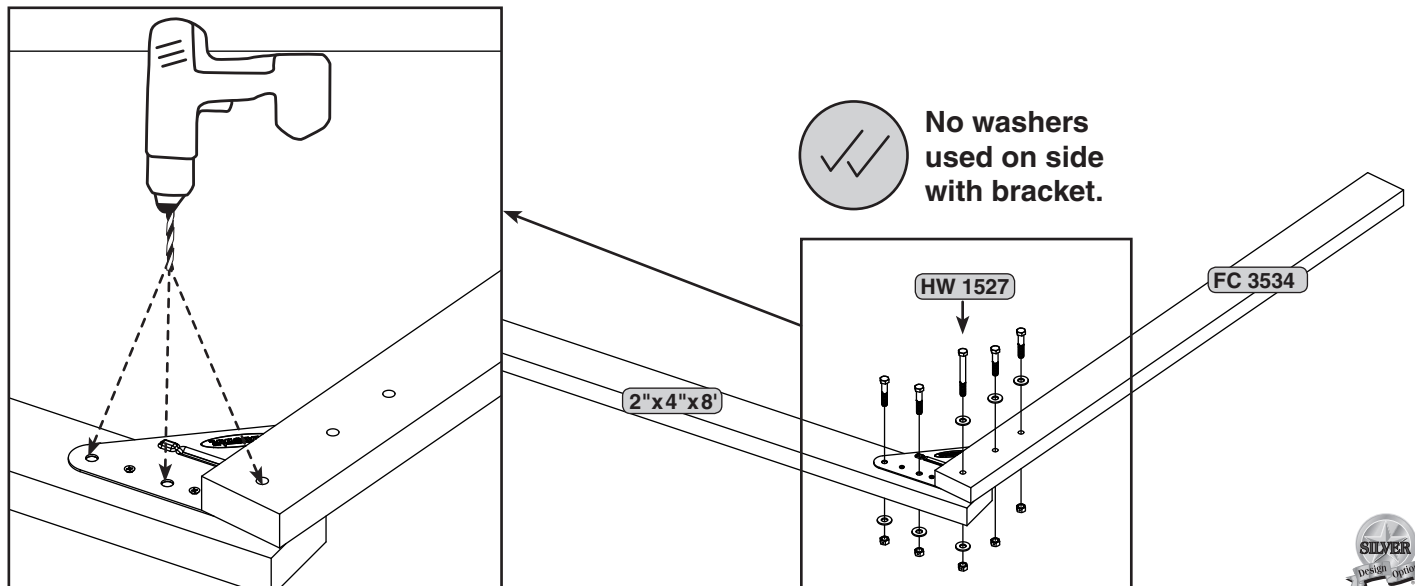
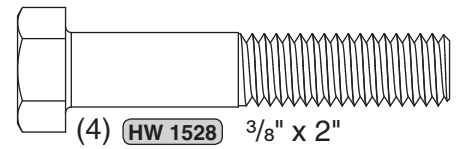
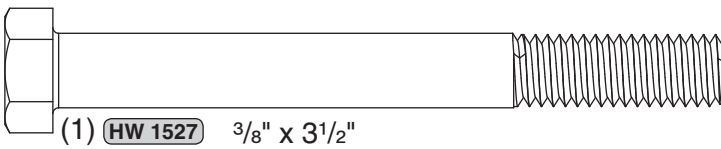
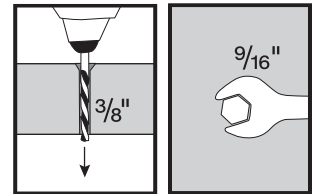
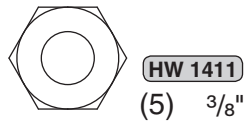
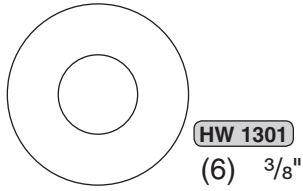

9

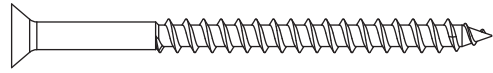

(8) HW 1204 #8 x 2 1/2"



(2) 2" x 4" x 2 1/2"

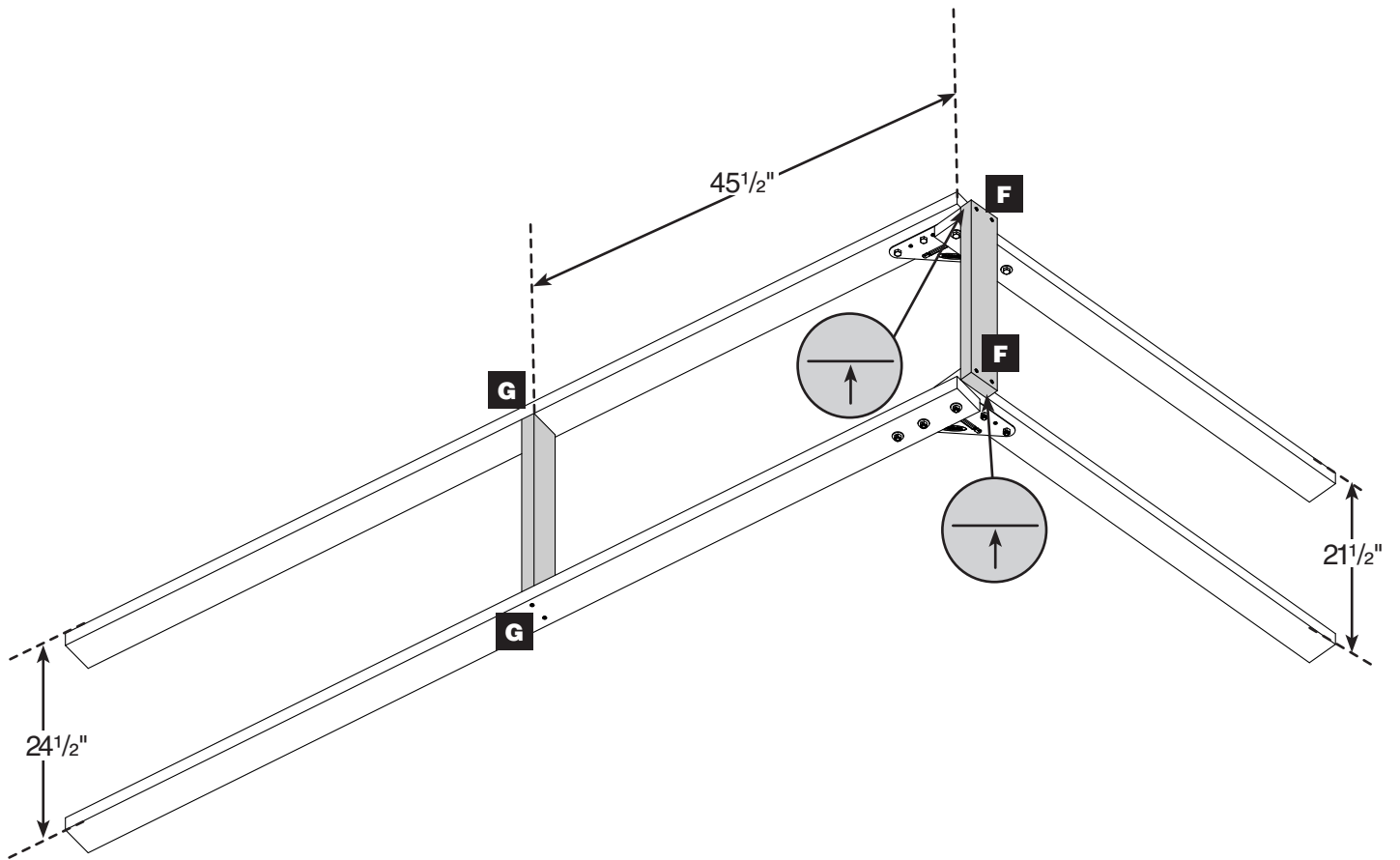
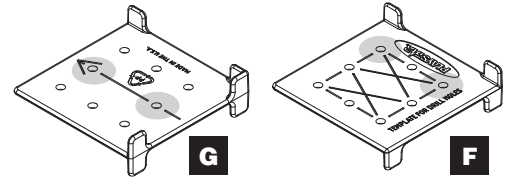
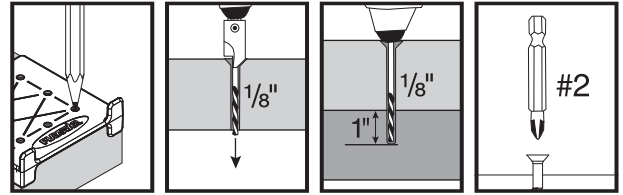

10

(Purchased Separately)

(1) PS 8870

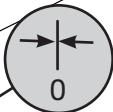

NOTE: Attach using hardware & Installation instructions included with PS 8870.

11



(6) HW 1611

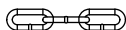

(6) FC 3108

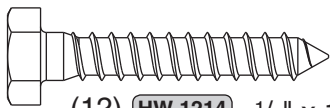

(12) HW 1214 1/4" x 1 1/2"

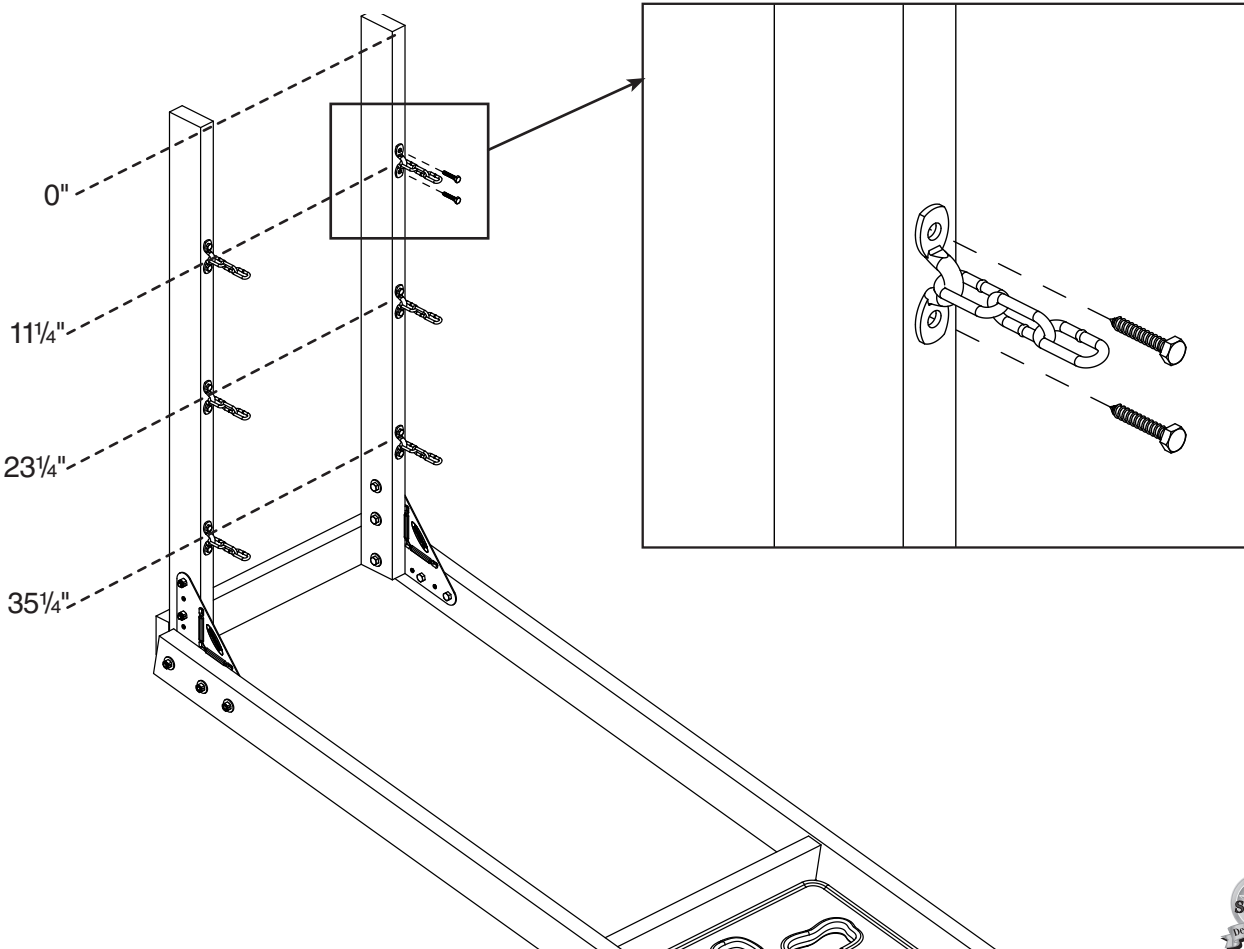
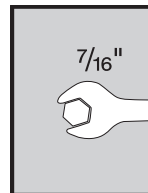
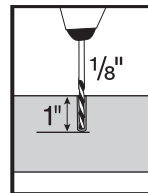
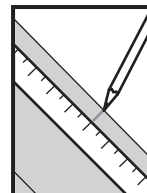

12

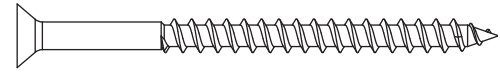

(4) HW 1204 #8 x 2 1/2"

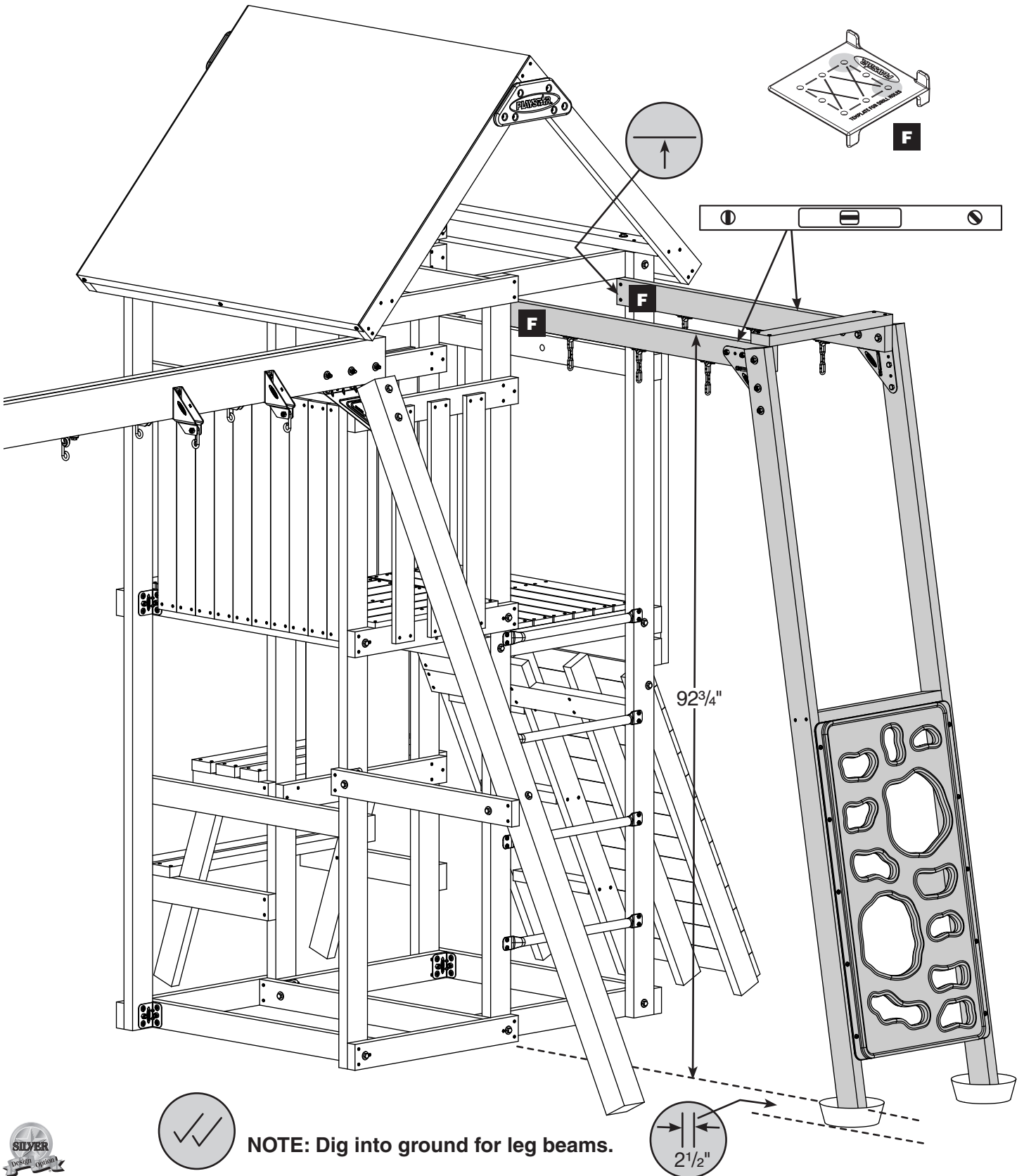
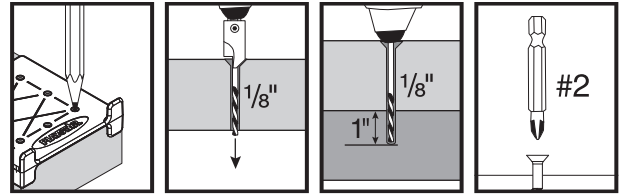

13



(2) SA 4496

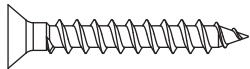

(8) HW 1213 #8 x 1 1/4"

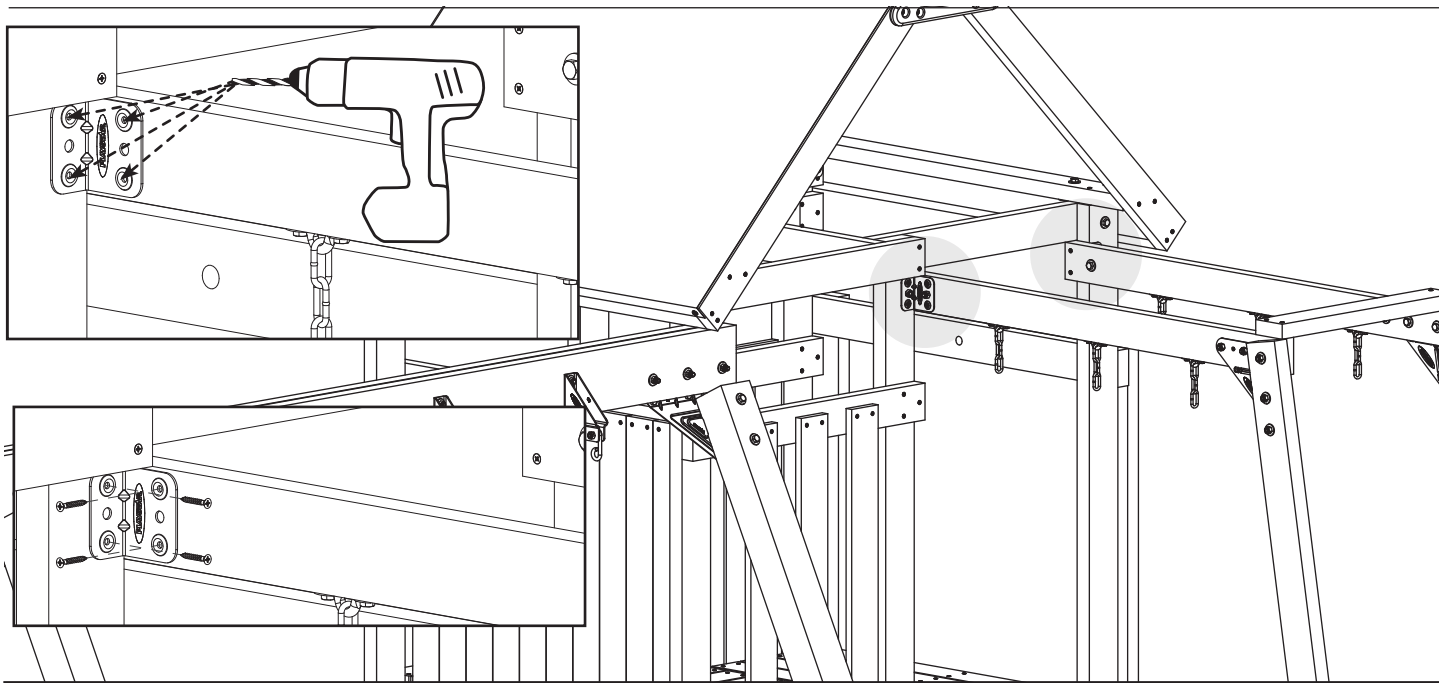
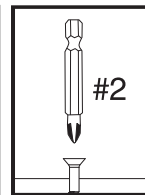
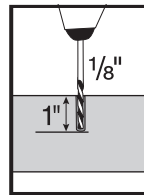

14

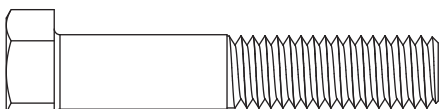

(4) HW 1528 3/8" x 2"

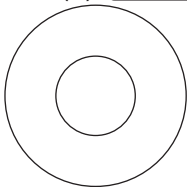

(4) HW 1301 3/8"

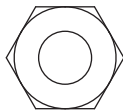

(4) HW 1411 3/8"

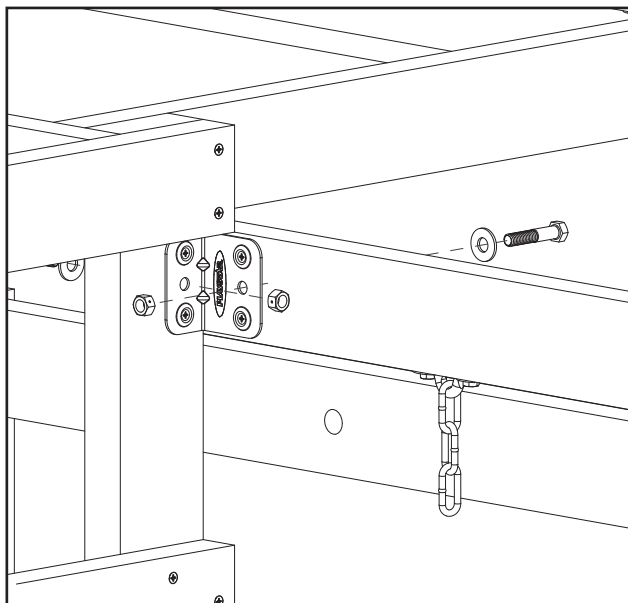
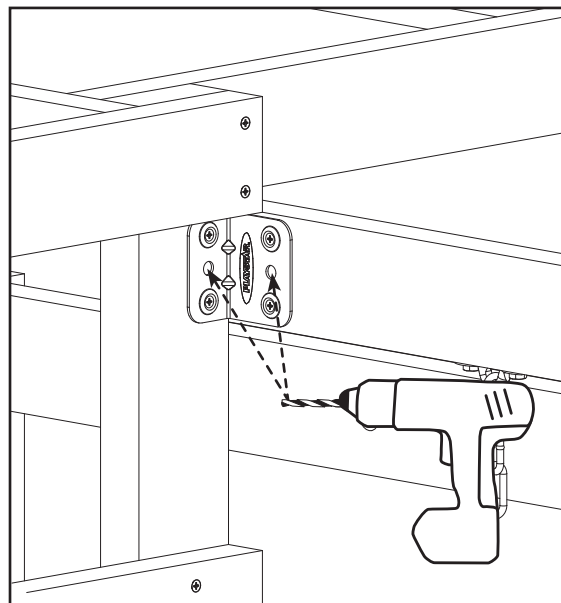
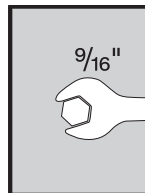
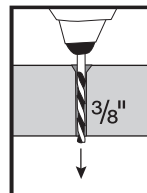

Anchoring

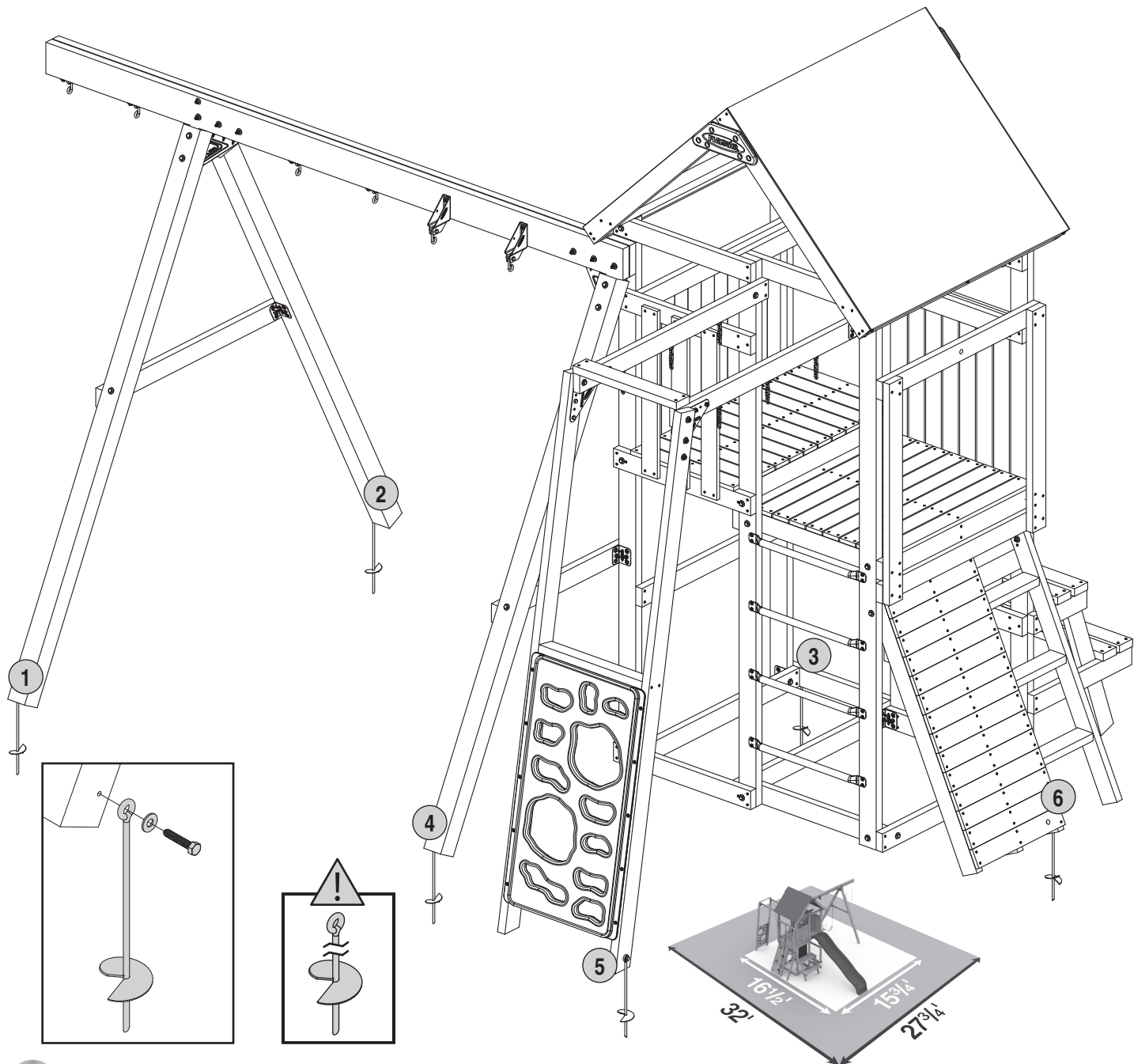
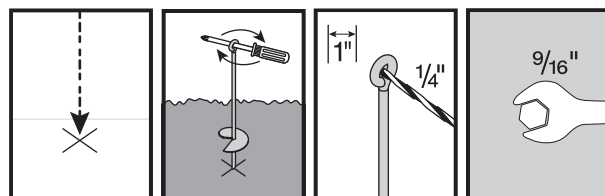
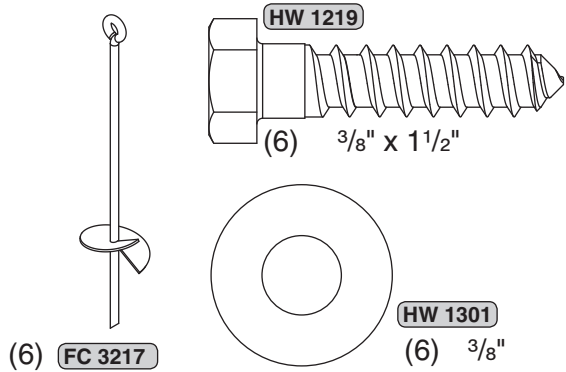

Safety Plaque

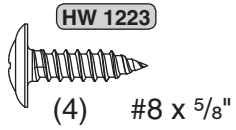

⚠ WARNING
THIS PRODUCT IS INTENDED FOR USE BY CHILDREN FROM AGES 2 TO 10 YEARS.
FOR HOME / RESIDENTIAL USE ONLY.
RISK OF SERIOUS HEAD INJURY OR DEATH DUE TO FALLS FROM EQUIPMENT PLACED OVER HARD SURFACES.
RISK OF USING HELMETS AND OTHER ITEMS THAT CAN WRAP AROUND A CHILD'S NECK, BECOME ENTANGLED OR ENTRAPPED BY THE EQUIPMENT, AND LEAD TO STRANGULATION OR DEATH.

⚠ ADVERTENCIA
ESTE PRODUCTO TIENE LA FINALIDAD DE SER USADO POR NIÑOS DE 2 A 10 AÑOS DE EDAD.
ÚNICAMENTE PARA USO DOMÉSTICO / RESIDENCIAL.
RIESGO DE HERIDA DE GRAVEDAD O DE MUERTE DEBIDO A CAÍDAS DEL EQUIPO CUANDO ESTE ES COLOCADO EN SUPERFICIES DURAS.
RIESGO CUANDO SE UTILIZAN CASCOS U OTROS ARTICULOS QUE PUEDAN ENROLLARSE AL REDEDOR DEL CUELLO DE UN NIÑO, Y ESTOS PUEDAN LLEGAR A ENREDARSE O A QUEDAR ATRAPADOS EN EL EQUIPO, Y CAUSAR ESTRANGULACIÓN O MUERTE.

⚠ AVERTISSEMENT
USAGE DE CE PRODUIT S'ADRESSE À DES ENFANTS DE 2 À 10 ANS.
POUR UN USAGE DOMESTIQUE/RESIDENTIEL EXCLUSIVEMENT.
RISQUE DE SÉRIEUSES BLESSURES À LA TÊTE ET MÊME DE MORT EN CAS DE CHUTES LORSQUE L'ÉQUIPEMENT EST INSTALLÉ AU-DESSUS D'UN REVÊTEMENT DUR.
RISQUE DE STRANGULATION ET MÊME DE MORT RELIÉ À L'UTILISATION DE CASQUE OU DE TOUT AUTRE OBJET POUVANT S'ENROULER AUTOUR DE L'ENFANT OU L'EMPRISONNER DANS CET ÉQUIPEMENT.

PlayStar, Incorporated
LT 7000
2104 Debit Ave., Janesville, WI 53547

(1) LT 7000



Place on Swing Beam or in prominent location on Playset.

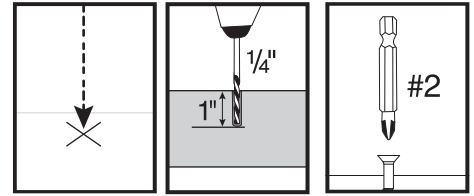

Sandbox Seat

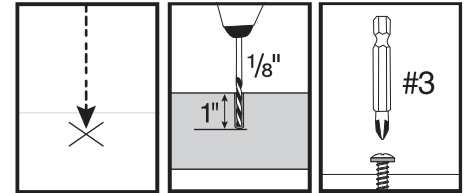
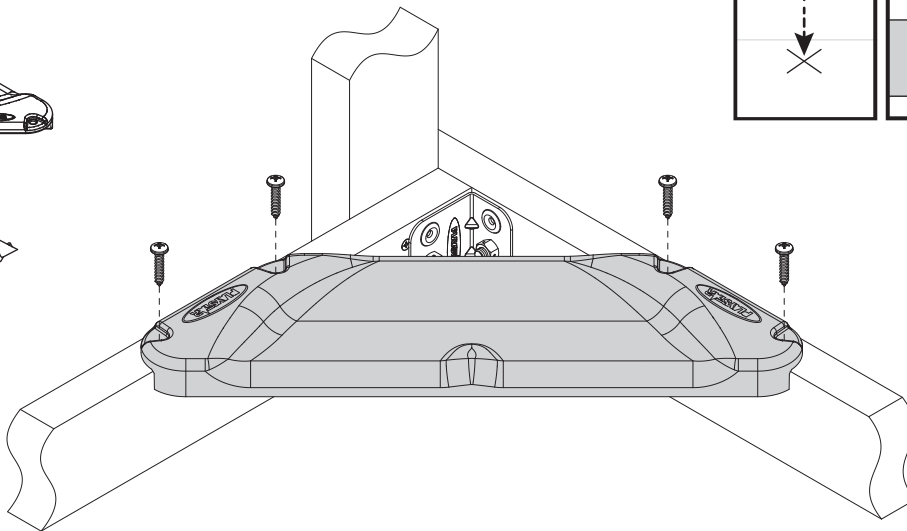
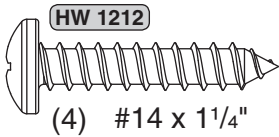
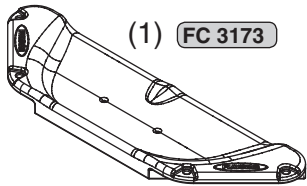

Monkey Rings

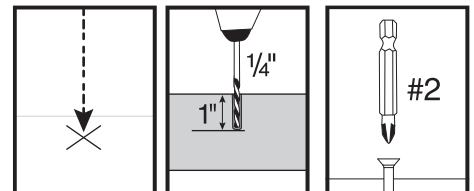
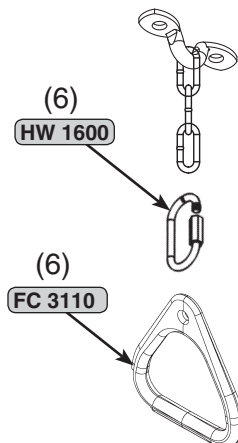
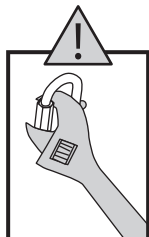

Window Attachment

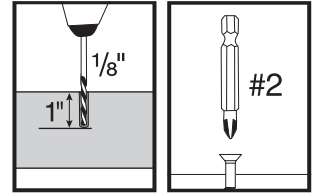
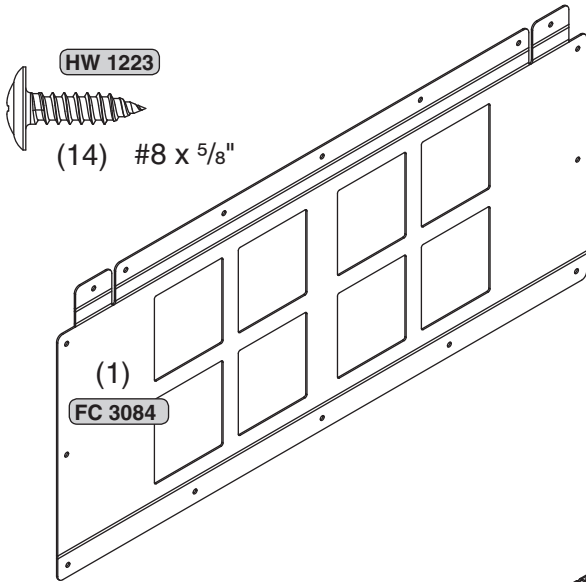

NOTE: Cut off two end tabs and fold top and bottom along scored lines as shown.

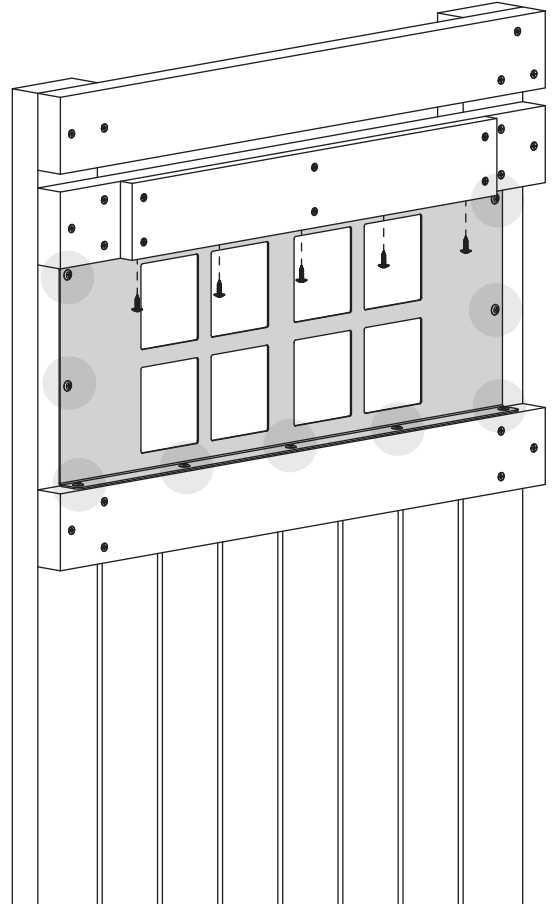
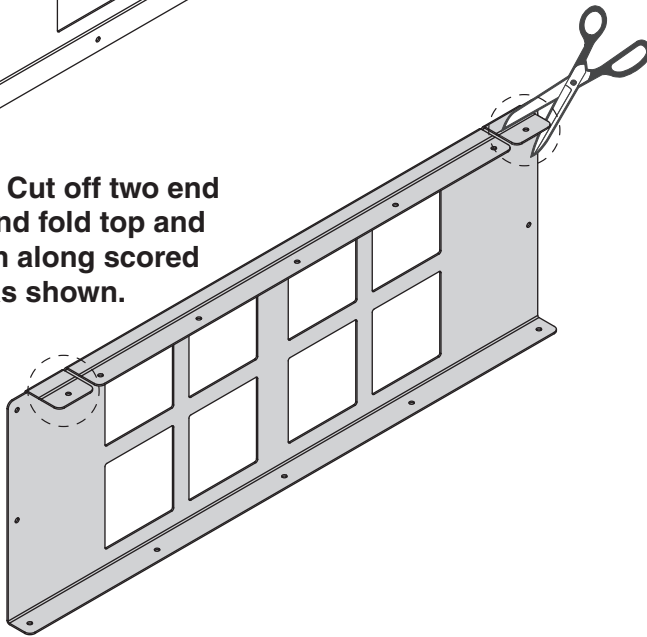

Play Handles

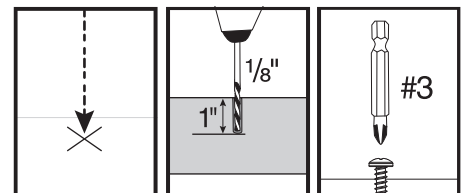
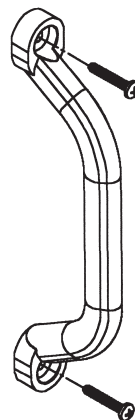
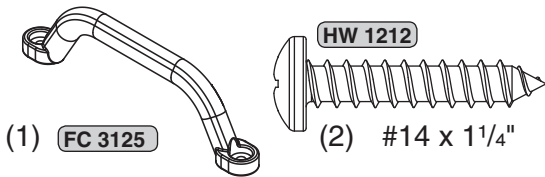

Telescope

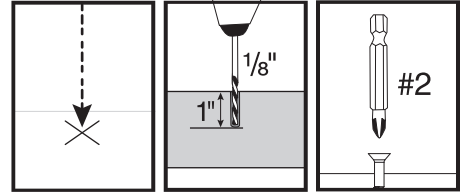
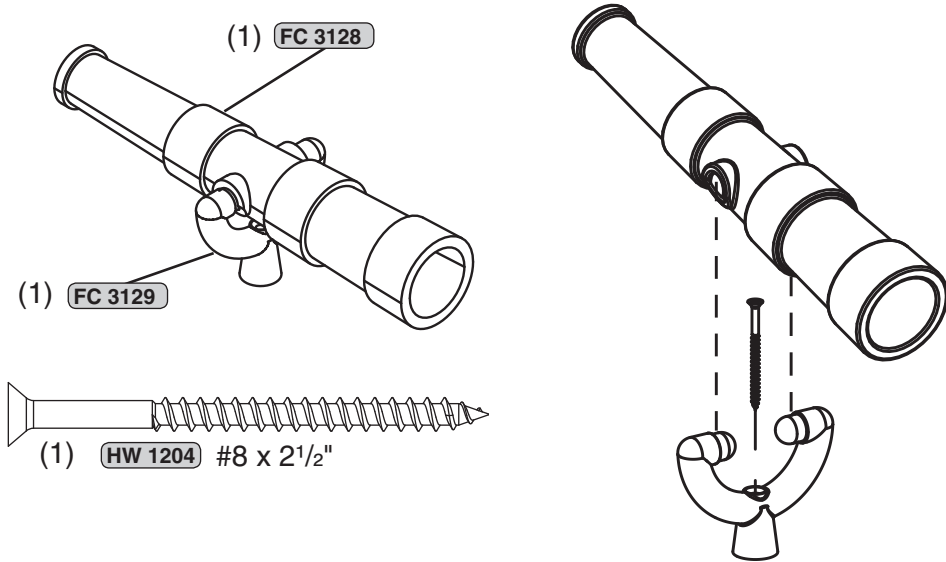

Rope

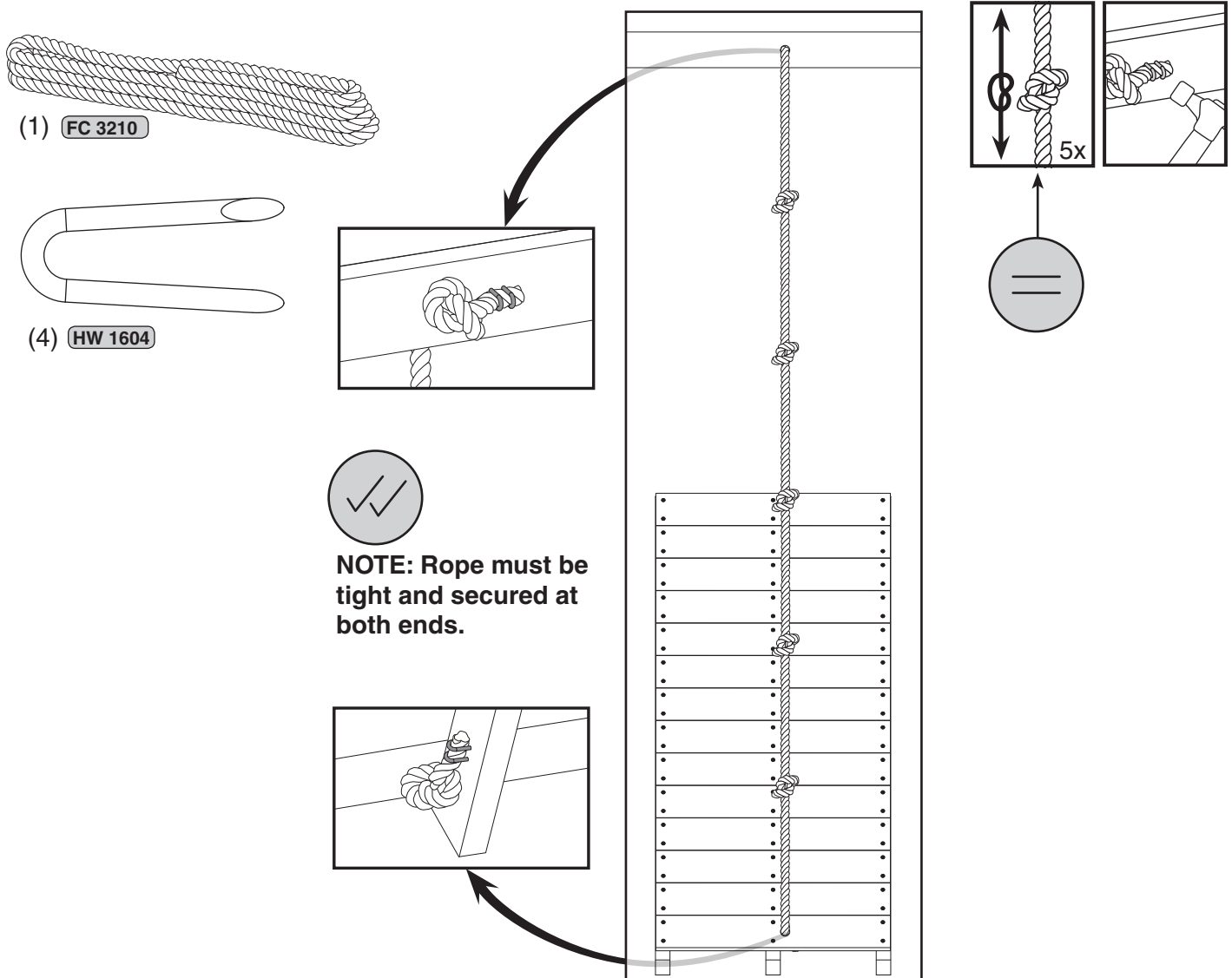

Climbing Rocks

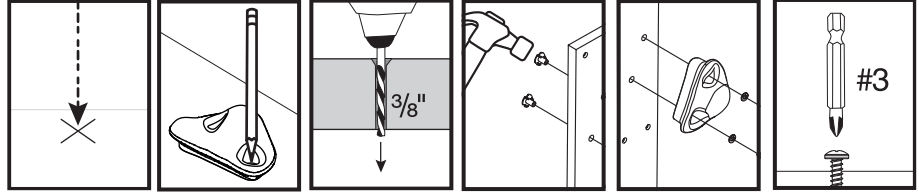

(8) HW 1309 1/4"

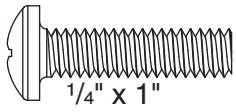

(8) HW 1217 1/4" X 1"



(1) FC 3213



(1) FC 3214

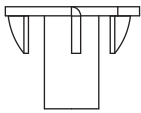

(8) HW 1474



(1) FC 3211



(1) FC 3212

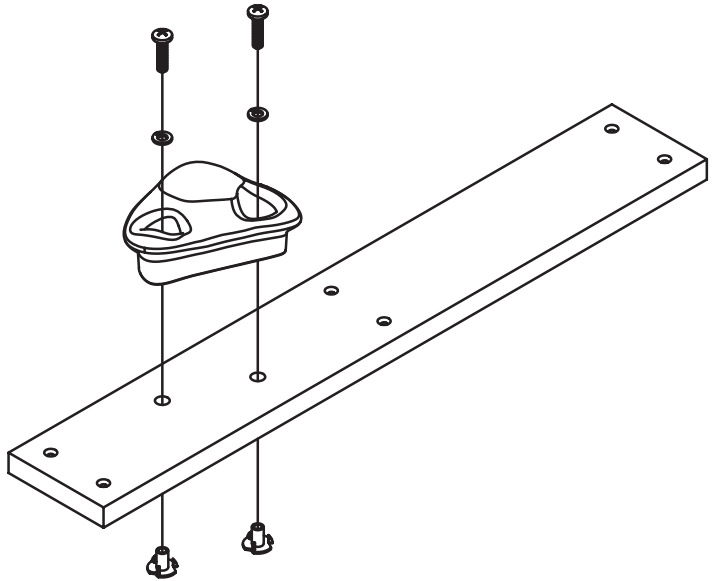

Swings and Rings

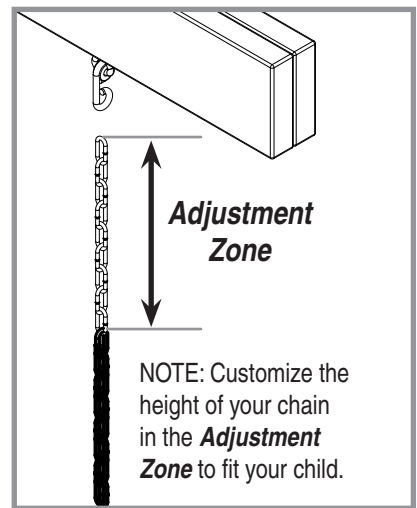
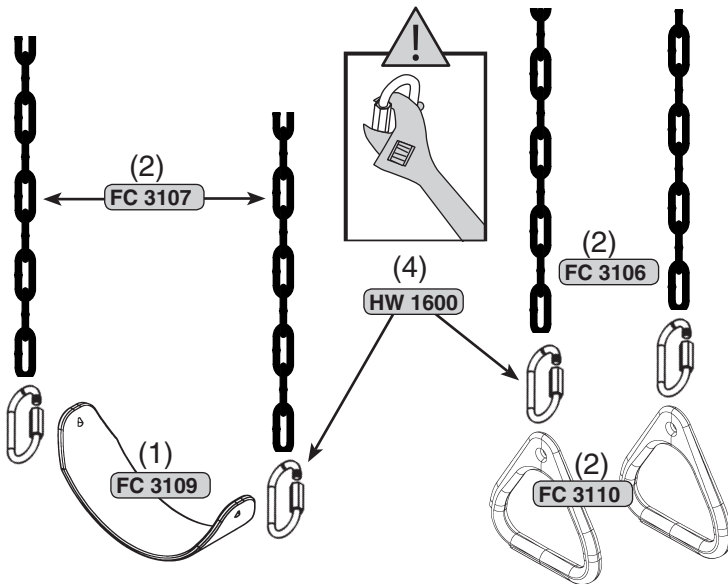

Slide

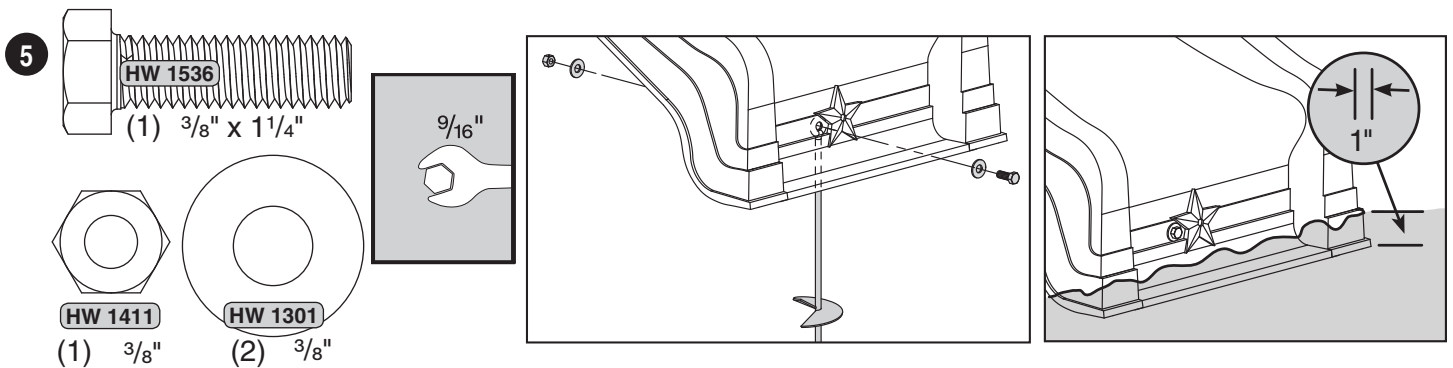
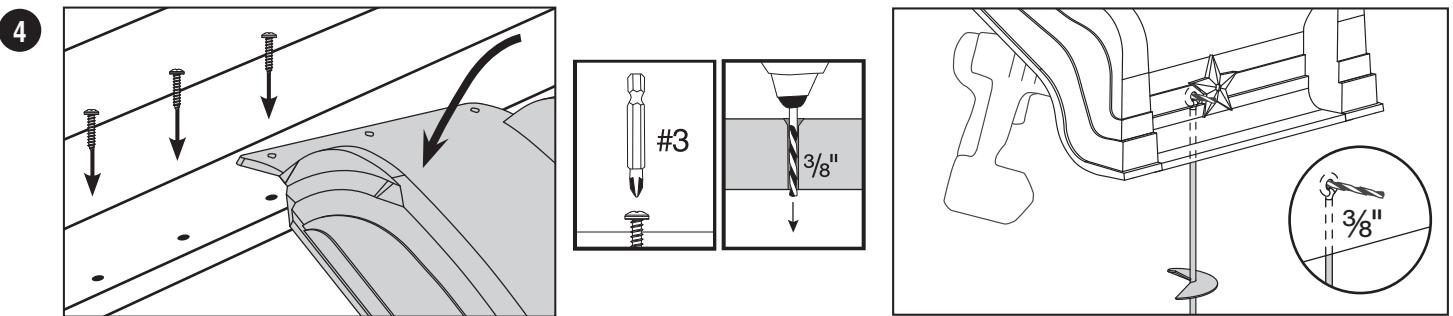
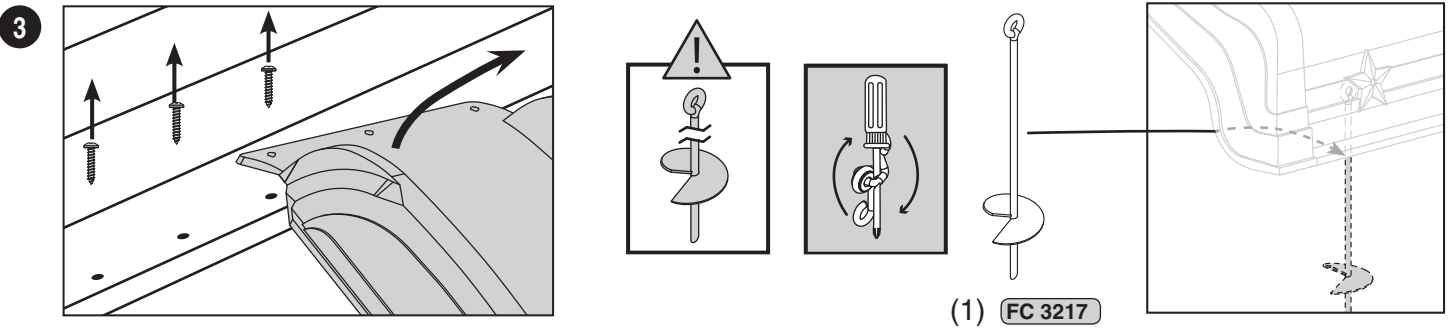
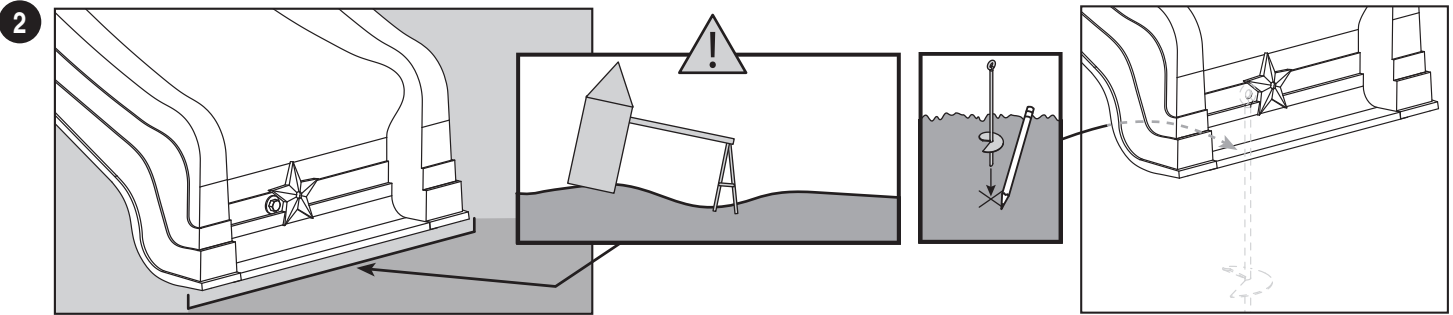
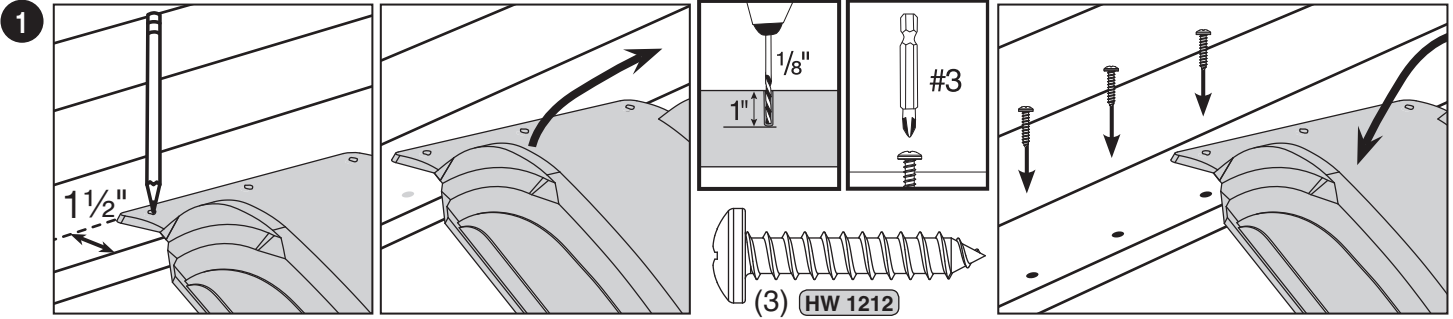

IMPORTANT – PLEASE READ

Thank You for choosing PlayStar. Because it is our intention to make this a positive family experience, we have taken great care in preparing this product.

All boards have been properly dried, thoroughly inspected for quality and dimensionally correct prior to packaging.

Occasionally a piece of lumber may develop a slight twist or bow due to changing humidity levels during transportation or storage. If this occurs, it can be straightened when attaching boards during the assembly process.

In a rare instance a severe twist or bow may occur and cause the board to be un-usable. If this happens do not return the board to the store.

Please call our friendly Customer Service Department for immediate action.

Do not return to the store.

If we can assist you in any way,

Please call us Toll Free at 1-888-PLAYSTAR

(752-9782)

Monday through Friday, 8:00 A.M. to 5:00 P.M. C.S.T.

Ask for Customer Service.

We Will Gladly Help!



PlayStar, Incorporated, Janesville, WI 53547

© 2017 PlayStar, Inc. Reproduction of this document in part or whole is prohibited without the permission of PlayStar, Inc.

Protected by one or more of the following United States or Foreign Patents: US D418,189; US D409,708; US D424,154; US D428,637; US 6,402,663; US D422,332; US D410,059; US 6,068,557; US 6,302,801; US 6,482,095; US 6,039,654; US D410,060; US D424,649; US 6,361,445; CA 2,304,345; US 6,540,645; US 6,709,365; US 6,942,600; US D513,779; US 6,991,550; CA D109,228; CA D109,224; CA D109,225; CA 2,304,113; US 6,629,907; US D517,636; US D518,530; US D520,590; US 520,591; US D534,613; US 7,186,183; US 7,189,034; US 7,253,951; US D548,760; US 7,304,810; CA D109,227; CA D109,226; CA D112,355; CA D113,437; CA D113,442; CA D114,067; CA D114,068; CA 2,304,896; CA D119,674; US D573,222; US 7,419,437; CA 2,304,068; CA 2,488,576; US D580,507; US D585,570; CA 2,490,923; CA 2,304,341; US 7,594,875; CA 2,304,043; CA 2,529,276; CA 2,633,628; CA 2,633,056; US 7,594,875; CA 2,498,701; CA 2,495,136; CA 2,488,600; CA 2,488,574